

Vent-Axia[®]

The UK's Leading Ventilation Company

Product Selector

Edition 18.4

www.vent-axia.com



Why choose Vent-Axia

Vent-Axia has been active for over 85 years in supplying ventilation solutions to countries around the world, whose Building Regulations demand the most effective, sustainable and energy efficient ventilation solutions.

We are with you all the way

- Unparalleled customer service
- Industry leading design support
- Providing support and solutions on-site

Availability

- With the widest distribution network of any manufacturer in the UK we pride ourselves on having products available when and where you need them

Product Solutions

- Whatever the product category, we have the most energy efficient systems available
- Unique solutions designed to fit into all your buildings
- With absolute focus on the end user we work hard to produce the quietest, most comfortable products for occupiers to live with



Made in Britain

Employing over 800 people across 3 manufacturing sites, we continue to invest in UK manufacturing.

Being in control of manufacture of the component parts including motors and mouldings all within the UK, we reduce our lead times as well as our carbon footprint.

Vent-Axia Group Ltd

Crawley - Unitary plastic fan manufacture

- Our largest total manufacturing and office space with over 230,000 sq. ft. housing the Vent-Axia Head Office
- Manufacturing and warehouse space totals 108,000 sq. ft.
- Manufacture of plastic ventilation ranges
- Design and test facilities for rigorous product testing including safety, airflow and climate chambers – BEAB approved
- Head Office functions including Sales Office, Customer Services, Technical Support and Marketing

Reading - Plastic Moulding and extrusion manufacture

- State of the art production facility
- Injection and extrusion factory running 24 hours a day
- Over 30 injection moulding machines
- 5 extrusion lines for rigid and flexible duct

Dudley - Systems and Industrial manufacture

- 120,000 sq footage of manufacturing and warehousing space
- Manufacturing base for our metal products including Sentinel Demand Ventilation and Sentinel Totus
- Also the home of our heat recovery (MVHR) and Multivent (MEV) products



Technical Advice

Free technical, installation and sales advice is available from the Vent-Axia Technical Support Centre.

Distribution

Vent-Axia products are available from all leading stockists. For further information, or in case of difficulty, please contact the Vent-Axia Sales Centre in Crawley.

Sound Levels

Vent-Axia has a state of the art sound testing facility at Crawley (UK) providing sound power levels for comparison purposes tested in accordance with ISO 13347-1:2004 and ISO 13347-2:2004. This is an international standard that describes methods for determining sound power levels of fans in one-third octave bandwidths to allow comparisons to be made between different products from different manufacturers in a fair and consistent manner.

The data is not intended to equal the sound power levels experienced in any specific installation but enable the customer to compare different products and make an informed decision on their requirements.

Each installation will use different building materials that can have an effect on how sound is absorbed and/or reflected. It is therefore very difficult to predict the exact sound power levels exhibited in any given installation.

Performance

Tested in Vent-Axia test laboratories, performance testing is carried out in a balanced chamber test duct to BS 848: Part 1. This has a booster fan to overcome the system resistance.

The volume flow is measured by a pressure drop across a calibrated orifice plate at the entry to the system.

An adjustable damper provides a variable resistance to the test fan enabling its performance characteristics to be measured. Unless stated otherwise, the rated figures given are at free air performance.

BS EN ISO 9001/14001

Vent-Axia limited is certified by the British Standards Institution to BS EN ISO 9001 Cert. No. FM1792 QAS No. 3284/37, and BS EN ISO 14001 Cert. No. EMS600403.

Intellectual Property

Products shown in this catalogue include aspects which are protected under patent, copyright, design copyright, registered design and trademark laws. Vent-Axia will take all necessary legal action in any part of the world against any party found to be manufacturing, distributing, selling or otherwise dealing with any article which infringes the Company's rights in its products.

Warranty

Applicable to units installed and used in the United Kingdom.

For details of warranty outside the United Kingdom, contact your local supplier.

Please visit our website www.vent-axia.com/help/product-warranties for details of warranty periods.

In the event of any part being found to be defective, the appliance will be repaired, or at the Company's option, replaced, without charge, provided that:

1. The product has been installed and used in accordance with the instructions given with each unit;
2. The product has not been connected to an unsuitable electrical supply (the correct electricity supply voltage is shown on the appliance rating label attached to the unit);
3. The product has not been subjected to misuse, neglect or damage;
4. The product has not been modified or repaired by any person not authorised by the Company;
5. The application is within the specification of the unit;
6. The product is connected to Vent-Axia switch gear;
7. Thermal overload protection has been correctly connected;
8. The product has been subject to regular maintenance appropriate to the installation;
9. When returning the product under warranty, evidence of purchase is provided.

Conditions of sale

All sales by Vent-Axia are made only upon the terms of the Company's Conditions of Sale (www.vent-axia.com/help/conditions-sale), a copy of which may be obtained upon request.

Online Ventilation & Heating Tools

Each tool has been designed with you in mind, making it simple to use and effective to apply, visit www.vent-axia.com/tools-services.

Online Product Selector

Our fully comprehensive online product selector tool. Choose from our complete specification range to best suit your project.

Online CPD

Vent-Axia offers a selection of CPD material online. With the addition of a questionnaire, you can independently complete your chosen module at your own convenience.

Online Trade Counter

Distributors with accounts can log in or register to check our livestock system for prices & stock availability & also review your previous trade orders.

Online Heating Calculators

By using the Vent-Axia Online Sizing Guides, you will be able to determine which product is suitable for you, helping you to achieve thermal comfort all year round.

Online Axial Fan Calculator

An interactive tool to help you calculate the installed performance of an axial fan when it's being tested with a vane anemometer.

Energy Related Products Directive (ErP)

The Eco-design for Energy-Related Products 2010 legislation regulates energy-consuming products.

The legislation sets minimum performance criteria across a range of fans, ventilation devices and heating products.

As of January 2016 ventilation devices over 30 Watts came under the scope of the Energy Related Products Directive under two sets of legislation; 'residential' ventilation and 'non-residential' ventilation, with levels further tightened in January 2018.

As of January 2018 the Directive came in to force for local space heating products, including storage heaters, electric radiators, radiant heaters and underfloor heating.

As a result of the legislation we reviewed our products and where required made updates to ensure they comply. The primary changes have meant that a number of products have had alternative motors specified or have been updated to enable speed control. In the case of heating, some products have been discontinued or updated to new models. Through the review we have also taken the opportunity to rationalise our range where needed. All relevant products in this literature have been updated as required by the ErP legislation. Please note that where a product changes due to ErP, there will be a transitional period as we move from the old to the new model, and any stock you currently hold will not be affected by this regulation and can be sold as normal.

Residential Fans

Residential Products has a secondary directive which requires some products to carry an energy label as described below:

Residential Ranges - Small fans

The majority of small residential fans are unaffected by the legislation as any device below 30 Watts is currently out of scope. The information on them is recorded however and can be found at www.vent-axia.com/erp

MVHR and MEV products

These products do come into the scope of the legislation and will carry an energy label. There are some minimum energy efficiency requirements as well as the requirement for a summer bypass on heat recovery models. A small number of our products have been updated to ensure they meet these requirements.

Energy Efficiency Class

Products within the scope of ErP now carry a rating that shows their Energy Efficiency Class. This information is called a 'SEC Class' and is provided in all product literature and on the energy label.

A product's SEC class is affected by how the product is controlled. This is referred to as Local Demand Control (LDC) and indicates how many 'sensors' a fan should have. The regulations require that single room fans, such as a bathroom fan, should have at least 1 sensor. Units that are ducted, such as an MEV unit, need to have more than one sensor. Examples of these are a pull cord/light switch or humidistat.

In our literature, where appropriate we have shown the rating if an additional LDC was added to a product. In those cases, you will see a table similar to the one below which has a heading (incl LDC). This is so you can choose the most efficient option for your needs.

SEC Rating Example

Model	SEC Class*	SEC Class (incl. LDC)
HR200	C	B

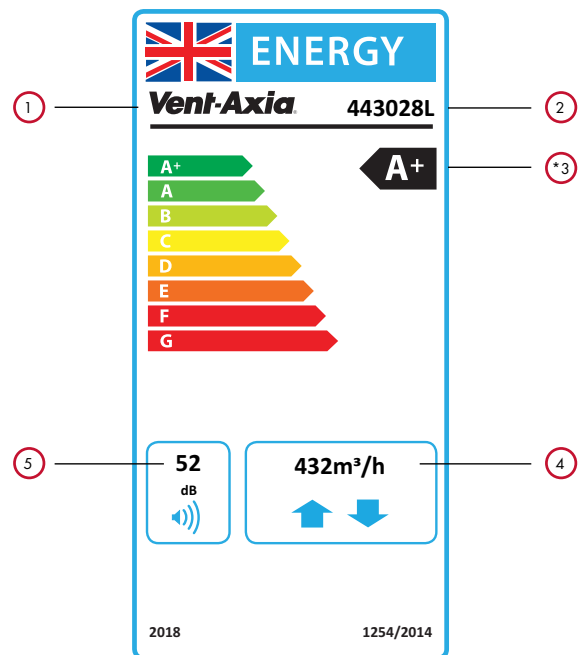

- ① Manufacturers name
- ② Model name
- ③ Energy Efficiency Class
- ④ Max flow rate
- ⑤ Sound Level

Non-Residential Ranges

Non-Residential products have had minimum performance and efficiency levels tightened, but there is no requirement to introduce energy labels. Some products have been updated with new motors and enabled for speed control.

Non-Residential ranges are split into a number of different categories dependent on their application and function. These can be described as follows:

1. Fans
2. Uni-directional Ventilation Units
3. Bi-directional Ventilation Units

1. Fans

These are products where there is a simple single case that directs air on and off the impellor. Examples include axial plate and case fans. These examples are out of scope of this legislation.

2. Unidirectional ventilation units

This includes products that are one direction only, and where there is a secondary housing around a fan.

This is the product category which required the most changes. The impact of the efficiency legislation meant that it became virtually impossible to comply using a forward curved AC centrifugal fan. We therefore moved to backward curved centrifugal fans in all of our AC box fan ranges. This meant changes to the box sizes and adjustment to performances, the following ranges are particularly affected.



ACQ/ATQ



QP/QPTW

We had a number of product ranges that were reaching the end of their life cycle and we have taken the opportunity to rationalise these. See our latest Specification Brochure for specific details on our current ranges.

We have also increased our use of EC motors by replacing the old SLP and SLPT range with a new EC version with basic integral commissioning potentiometer allowing the installer to set the exact performance requirements without need for additional controls and wiring.

3. Bi-directional ventilation units

These are product ranges that both supply and extract such as heat recovery units.

There are now minimum energy requirements set for heat recovery efficiency. Any product with an efficiency of 72% or lower does not comply. The Sentinel Totus² Range of heat recovery units has efficiencies of up to 90% which comfortably exceed this minimum requirement. See our Specification Brochure for more details.

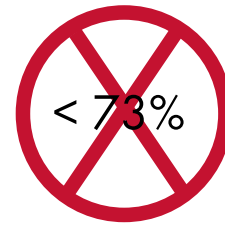

Heat recovery minimum efficiency

Electric Space Heating

From 1st January 2018, under 'Lot 20' all local electric space heaters must comply with a minimum efficiency standard. The aim of this legislation is to remove inefficient technologies and reduce the energy used by the products that heat our homes.

In order to comply with the Lot 20 regulations, all local space heaters have to meet a minimum efficiency.

As a result, the following products have been discontinued:

- Optimax Plus Combination storage Heater
- Portable Fan Heater
- Downflow heater
- Plinth heater

Replacements for these products may be introduced in the future.

The following products have been updated to a Lot 20 compliant model:

- Optimax Plus Panel Heater
- Optimax Plus Storage Heater

Contents

AIR PURIFIERS	A:1-A:6	Centrif Duo Centrifugal Kitchen & Utility Room Fan	C:25-C:26
Vent-Axia PureAir Room 500 X with CodiKoot	A:3-A:4	Centrif Duo Plus Centrifugal Kitchen & Utility Room Fan	C:27-C:28
Vent-Axia PureAir Room	A:5-A:6	Freshvent Natural Vent	C:29-C:30
		Basics Range	C:31-C:32
		Eclipse Bathroom & Kitchen Axial Fan	C:33-C:34
LO-CARBON RESIDENTIAL FANS	B:1-B:27		
Vent-Axia Lo-Carbon iQ Bathroom/Toilet Fan	B:3-B:4	dMEV, MEV & PIV SYSTEMS	D:1-D:20
Vent-Axia PureAir Sense Bathroom/Toilet Fan	B:5-B:6	NEW Lo-Carbon NBR dMEV C	D:3-D:4
Lo-Carbon Svava Axial Bathroom/Toilet Fan	B:7-B:8	Lo-Carbon Centra®/SELV dMEV Unit	D:5-D:6
NEW LoCarbon Silent Fan Axial Bathroom/Toilet Fan	B:9-B:10	Lo-Carbon Response 7/SELV dMEV Unit	D:7-D:8
Lo-Carbon VA100®/SELV Axial Bathroom/Toilet Fan	B:11-B:12	Lo-Carbon Sentinel® Multivent/Plus	D:9-D:12
Lo-Carbon Silhouette® 100/SELV Bathroom/Toilet Fan	B:13-B:14	Lo-Carbon MVDC-MS/MSH Multivent	D:13-D:14
Lo-Carbon Centra®/SELV dMEV Unit	B:15-B:16	Lo-Carbon NBR dMEV/dMEVe	D:15-D:16
Lo-Carbon Revive/SELV Bathroom/Kitchen Filterless Fan	B:17-B:18	Lo-Carbon PoziDry Pro Positive Input Ventilation	D:17-D:18
Lo-Carbon Solo Plus/SELV Centrifugal Bathroom/Toilet Fan	B:19-B:20	Lo-Carbon PoziDry Compact Pro Positive Input Ventilation	D:19-D:20
Lo-Carbon Minivent Ducted Bath/Shower Fan Kit	B:21		
Lo-Carbon LED Vent-A-light Ducted Bath/Shower Fan Kit	B:22	SINGLE ROOM dMVHR	E:1-E:8
Lo-Carbon Quadra® Centrifugal Fan	B:23-B:24	NEW Lo-Carbon Calido	E:3-E:4
Lo-Carbon Silhouette® 125 Bathroom/Toilet Fan	B:25	Lo-Carbon Heat Save/Alternate Flow Heat Recovery	E:5-E:6
Lo-Carbon VA150 Axial Kitchen & Utility Room Fan	B:26	Lo-Carbon Tempra/SELV Single Rm Heat Recovery	E:7-E:8
Lo-Carbon Silhouette® 150 Axial Kitchen Fan	B:27	HR200WK/WJ Single Rm Heat Recovery	E:9-E:10
		HR300/Single Rm Heat Recovery	E:11-E:12
RESIDENTIAL FANS	C:1-C:34		
VA100/SELV 12 Axial Bathroom/Toilet Fan	C:3-C:4	MVHR FOR COMMERCIAL & RESIDENTIAL	F:1-F:56
Silhouette 100/SELV Axial Bathroom/Toilet Fan	C:5-C:6	Lo-Carbon Sentinel Kinetic® Advance MVHR Unit	F:3-F:6
NEW Silent Fan Axial Bathroom/Toilet Fan	C:7-C:8	Lo-Carbon Sentinel Kinetic® Range Overview	F:7-F:10
Silhouette 125 Axial Bathroom/Toilet Fan	C:9-C:10	Lo-Carbon Sentinel Kinetic® MVHR Unit	F:11-F:14
LED LuminAir Fan & Light Combination Unit	C:11-C:12	Lo-Carbon Sentinel Kinetic® FH MVHR Unit	F:15-F:18
LED LuminAir Fan & Light Ventilation Kit	C:13-C:14	Lo-Carbon Sentinel Kinetic® Plus MVHR Unit	F:19-F:22
LED LuminAir Turbo Fan & Light Ventilation Kit	C:15-C:16	Lo-Carbon Sentinel Kinetic® High Flow MVHR Unit	F:23-F:26
Solo Plus Centrifugal Bathroom/Toilet Fan	C:17-C:18	Lo-Carbon Sentinel Kinetic® Cooker Hood MVHR Unit	F:27-F:30
Solo Pro/SELV Centrifugal Bathroom/Toilet Fan	C:19-C:20	Lo-Carbon Sentinel Kinetic® Horizontal MVHR Unit	F:29-F:36
VA140/150 Axial Kitchen Fan	C:21	Lo-Carbon Kinetic® Plus E MVHR Unit	F:35-F:40
VA150 Window Mount Axial Kitchen Fan	C:22	Integra Ducted MVHR Unit	F:41-F:42
Silhouette 150 Axial Kitchen Fan	C:23-C:24		

Integra Plus EC Ducted MVHR Unit	F:43-F:44
HR100R/RS Ducted MVHR Unit	F:45-F:46
HR200V Ducted MVHR Unit	F:47-F:48
HR500 Single Room Heat Recovery Unit	F:49-F:50
HR500D Ducted MVHR Unit	F:51-F:52
HR500EP/IP Passive HR Unit	F:53-F:54
HR500DP Passive HR Unit	F:55-F:56

DUCTING & FITTINGS	G:1-G:36
--------------------	----------

COMMERCIAL RANGE	H:1-H:38
ACM 100-315 In-Line Mixed Flow Fan	H:3-H:6
Powerflow In-Line Duct Fan	H:7-H:8
Lo-Carbon T-Series	H:9-H:18
Traditional T-Series	H:19-H:32
Super T-Series Powerful Heavy Duty Wall Fan	H:33-H:34
Traditional Standard Range	H:35-H:38

HYGIENE	I:1-I:6
Hand Dryers	I:3-I:5
Insect Killers	I:5
Hand Sanitiser/ Soap Dispenser	I:5

COOLING	J:1-J:6
Hi-Line Plus 35-55" Ceiling Sweep Fans	J:3
Stanza 48" Ceiling Sweep Fans	J:4
Jupiter De-Stratification Unit	J:5
12" Wall Fan Portable Cooling	J:6
14" Box Fan Portable Cooling	J:6

ELECTRIC HEATING	K:1-K:8
Heated Towel Rails	K:3-K:4
Radiant Heaters	K:5-K:6
Lot 20 Panel Heater	K:7
Warm Air Curtains	K:8

ACCESSORIES & CONTROLLERS	L:1-L:18
---------------------------	----------

ROOF UNITS INDUSTRIAL	M:1-M:57
EuroSeries® (ESP) Plate Mounted Axial Fans	M:3-M:10
EuroSeries® (ESC) Short Case Axial Fans	M:11-M:18
EuroSeries® (ESR) Fan Assisted Roof Cowls	M:19-M:26
Quiet Pack (QP) In-Line Centrifugal Duct Fans	M:27-M:30
Quiet Pack (QPTW) In-Line Twin Fans	M:31-M:34
Slimpak EC Box Fan (SLP EC) In-Line Centrifugal Fans	M:35-M:40
Slimpak EC Box Fan (SLPT EC) In-Line Twin Duct Fans	M:41-M:46
EuroSeries® (SDX) In-Line Centrifugal Duct Fans	M:47-M:50
Speed Controllers Single & Three Phase	M:51-M:52
Starter & Overloads	M:53
Sonex Circular Sound Attenuators	M:54
Pyrocheck (CVT) Intumescent Fire Dampers	M:55
Unitex Roof Cowl System	M:56
Unitex Wall Terminal (SA & QSA)	M:57

Air Purifiers



The Vent-Axia PureAir Room cleans the air that you breathe, protecting your health from the 900 chemicals, particulates and biological materials in the air inside your home.

The system provides an advanced multistage air cleaning system which removes these harmful particles, neutralises bad smells and removes pollen and pet allergens; purifying the air you and your family breathe for a fresher and healthier indoor environment.

Suitable for any internal habitable room, the purifier is portable so you can move it to where you need it most. It works automatically sensing the air quality and delivering increased filtration when it's needed.

Vent-Axia





Vent-Axia PureAir Room 500 X with CodiKoat
Portable Air Purification Unit

A:3-A:4



Vent-Axia PureAir Room
Portable Air Purification Unit

A:5-A:6

Vent-Axia PureAir Room 500 X with CodiKoat

- Seven-stage air purifier including a medical grade H13 HEPA filter
- Removes 99.9% of airborne particles including COVID-19, viruses and bacteria
- UV sterilisation and Ionizer built in
- Quiet, multi speed operation
- Child safety lock
- Filter replacement indication
- Quality is assured with a two-year warranty
- Includes Type G British 3-pin electrical plug
- Includes WIFI control/ Remote control
- Odour and dust sensor
- Control via app



We spend more than 90% of our time indoors, breathing up to 50 times more polluted air than outdoors. The air can contain over 900 chemicals, particulates, biological materials, viruses and bacteria, all contributing to our health, concentration and well-being.

The Vent-Axia PureAir Room 500 X with CodiKoat is an advanced seven-stage air cleaning system, which removes harmful particles and neutralises bad smells. This air purifier reduces the effects poor indoor air quality can have on the health of everyone in your home.

Thanks to the three-speed settings to choose from, the Vent-Axia PureAir Room 500 X with CodiKoat is not only suitable for your home, but for all types of indoor environments such as hotels, offices, schools and public environments. The air purifier is ideal for rooms up to 65m² and has a maximum noise level of 45d(B)A, so you will not be disturbed by loud background noise. Additionally, at night, you have the option of a sleep mode, which reduces the sound of the purifier, ensuring a good night's sleep.

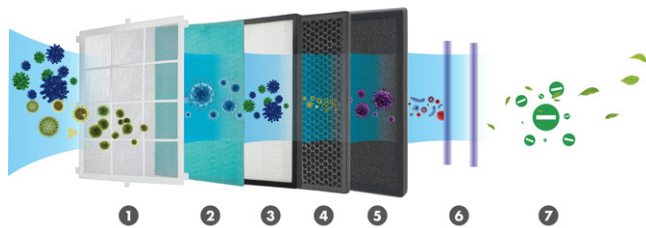

1. Washable Pre-Filter

The washable pre-filter removing large granule dust, dander, pollen, floating compound and other pollutants in the air.

2. Pre-Filter

This pre-filter is also a washable coarse particle filter, which collects the larger particles from the air flowing through it. This process additionally protects the HEPA PLUS[®] filter from these particles and thus increases the service life of the following filters elements.

3. Medical grade H13 HEPA PLUS[®] filter with CodiKoat treatment

This part of the filter is treated with a protective anti-bacterial coating, providing an extra layer of protection. It traps and kills virus and bacteria particles within seconds of contact. The HEPA PLUS[®] filter also removes 99.9% of particles in the air including PM2.5, pet allergens, pollen, by trapping them inside the filter material.

4. Activated Carbon Filter

Activated carbon filter has a huge surface area, which removes volatile organic compounds (VOCs), odours and other gaseous pollutants from the air by trapping the gas molecules in the charcoal.

5. Cold Catalyst Filter

The cold catalyst filter speeds up the decomposition of organic compounds in the air, breaking them into molecules such as H₂O and CO₂, which are harmless to the human body.

5. Ultraviolet Light

Ultraviolet light technology is used as a disinfection method using short-wavelength ultraviolet light to inactivate bacteria and viruses sanitising the air around you.

6. Ionizer

The ionizer is the last stage of the filtration process, generating negatively charged ions which adhere to small particulate materials statically charging them. This attracts other particles creating larger clusters, that can then be absorbed by the filter at the start of the cycle.

Unique CodiKoat Filter Treatment

CodiKoat have developed the fastest acting ISO certified antimicrobial and antiviral coating technology. This unique nano treatment on the third filter layer of the Vent-Axia PureAir Room 500 X removes and destroys viruses (including COVID-19), bacteria and fungi within seconds of contact from the air that we breathe, delivering healthier environments and improved indoor air quality.

Useful Features

Other features include a child safety lock to ensure that the unit is not tampered with. Auto mode that sets airflow based on the indoor air pollution, using a simple traffic light system to let you know the unit's progress. Air quality display and a timer to allow you to set the unit to run for periods up to eight hours. The unit uses a British 3-pin plug, so you can plug and go without the need for an installer. This also means that the unit is portable, so you can move it around, as you require.

Models

Air cleaner for indoor environments

Model
PureAir Room 500 X with CodiKoat

Stock Ref
411370



Accessories

Model
CodiKoat replacement filter

Stock Ref
411159

Dimensions (mm)

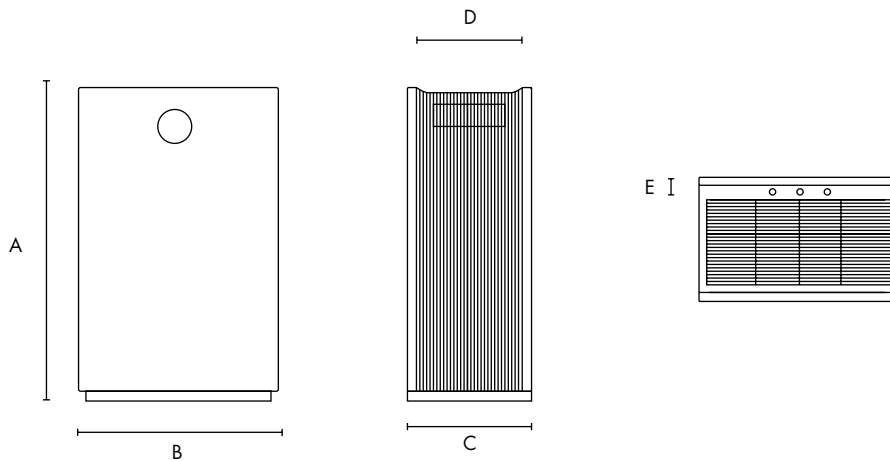

A	B	C	D	E
640	400	260	255	60

Net weight: 10.04kg. Gross weight: 11.7kg

Performance

Clean Air Delivery Rate (CADR): 500m³/h

Coverage: Up to 65m²

App Control

The Vent-Axia PureAir Room 500 X with CodiKoat comes with the SmartLife app.

SmartLife is a mobile app to control smart home products through smartphones or tablets and also enables voice control via Amazon Echo and Google Home.

The SmartLife app is available for both iOS and Android operating systems and is available to download in the app stores for use with the Vent-Axia PureAir Room 500 X with CodiKoat.

Vent-Axia PureAir Room

- Six stage air purifier including a medical grade H13 HEPA filter
- Removes 99.9% of airborne particles including COVID-19, viruses and bacteria
- UV sterilisation and Ionizer built in
- Quiet, multi speed operation
- Child safety lock
- Filter replacement indication
- Quality is assured with a two-year warranty
- TÜV SÜD approved
- Includes Type G British 3-pin electrical plug



Vent-Axia PureAir Room

The Vent-Axia PureAir Room is an advanced six-stage air cleaning system, which removes harmful particles and neutralises bad smells. This air purifier reduces the effects poor indoor air quality can have on the health of everyone in your home.

The Vent-Axia PureAir Room is not only suitable for your home, but for all types of indoor environments such as hotels, offices, schools, public environments thanks to the three speed settings to choose from. The air purifier is ideal for rooms up to 30m² and has a maximum noise level of 45d(B)A, so you will not be disturbed by loud background noise. Additionally, at night, you have the option of sleep mode, which reduces the sound of the purifier, ensuring a good night's sleep.

We spend more than 90% of our time indoors, breathing up to 50 times more polluted air than outdoors. The air can contain over 900 chemicals, particulates, biological materials, viruses and bacteria, all contributing to our health, concentration and well-being. We breathe 9,000 litres of air each day, so it is important that the air is fresh and creates a healthy indoor environment. What sets the Vent-Axia air purifier apart from many competitors is the six-stage filtration system that purifies the air. The six stages are:

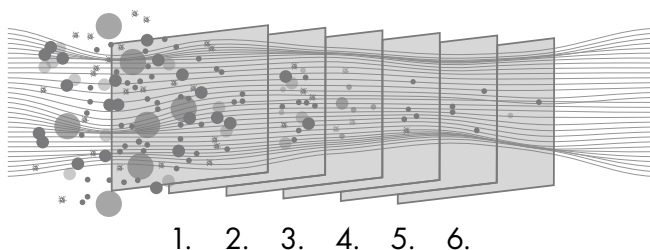

1. Washable Pre-Filter

The pre-filter is a washable coarse particle filter, which collects the larger particles from the air flowing through it. This process additionally protects the HEPA filter from these particles and thus increases the service life of the following filters elements.

2. H13 HEPA Filter

The H13 'High-Efficiency Particulate Air' medical-grade air filter removes 99.9% of particles in the air including PM2.5, pet allergens, pollen, viruses, mould and bacteria by trapping them inside the filter material.

3. Activated Carbon Filter

Activated carbon filter has a huge surface area, which removes volatile organic compounds (VOCs), odours and other gaseous pollutants from the air by trapping the gas molecules in the charcoal.

4. Cold Catalyst Filter

The cold catalyst filter speeds up the decomposition of organic compounds in the air, breaking them into molecules such as H₂O and CO₂, which are harmless to the human body.

5. Ultraviolet Light

Ultraviolet light technology is used as a disinfection method using short-wavelength ultraviolet light to inactivate bacteria and viruses sanitising the air around you.

6. Ionizer

The ionizer is the last stage of the filtration process, generating negatively charged ions which adhere to small particulate materials statically charging them. This attracts other particles creating larger clusters, that can then be absorbed by the filter at the start of the cycle.

Useful Features

Other features include a child safety lock to ensure that the unit is not tampered with. Auto mode that sets airflow based on the indoor air pollution, using a simple traffic light system to let you know the unit's progress. Air quality display and a timer to allow you to set the unit to run for periods up to eight hours. The unit uses a British three pin plug, so you can plug and go without the need for an installer. This also means that the unit is portable, so you can move it around, as you require.

Models

Air cleaner for habitable rooms

Model

PureAir Room Air Purifier

PureAir Room X Air Purifier with App Control

Stock Ref

496611

496612

App Control

The Vent-Axia PureAir Room X model comes with the SmartLife app.

SmartLife is a mobile app to control smart home products through smartphones or tablets and also enables voice control via Amazon Echo and Google Home.

The SmartLife app is available for both iOS and Android operating systems and is available to download in the app stores for use with the Vent-Axia PureAir Room X.



Accessories

Model

Filter Unit

Stock Ref

496613

Dimensions (mm)

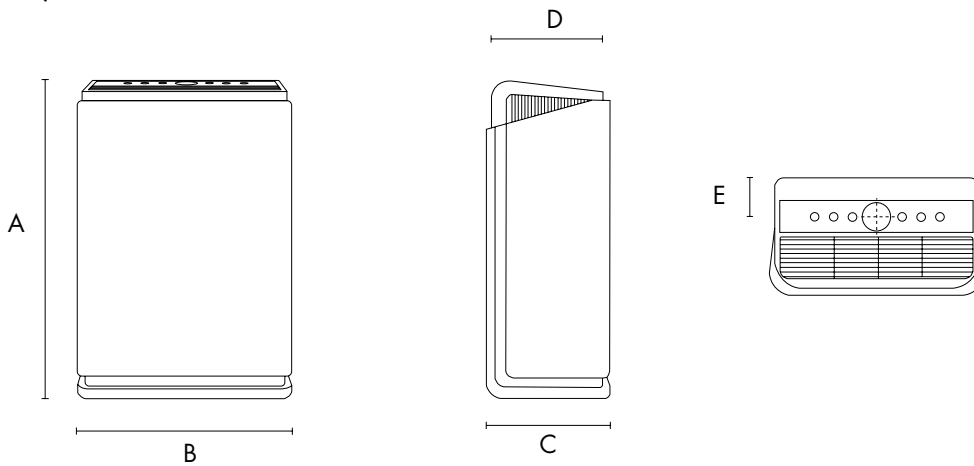

A	B	C	D	E
560	350	230	190	88

Weight 5.8kg

Performance

Clean Air Delivery Rate (CADR): 260m³/h

Coverage up to: 30m²



Lo-Carbon Residential Fans



Continuing our commitment to energy efficiency in this section you will find Lo-Carbon solutions for intermittent and continuous fan applications.

In axial or centrifugal, wall, ceiling or window applications in bathrooms or kitchens we have a Lo-Carbon fan offering up to 90% energy saving over the equivalent traditional fan.

Vent-Axia[®]

	Vent-Axia Lo-Carbon iQ Bathroom/ Toilet Fan	B:3-B:4
	Vent-Axia PureAir Sense Bathroom/ Toilet Fan	B:5-B:6
	Lo-Carbon Svara Axial Bathroom/Toilet Fan	B:7-B:8
	Lo-Carbon Silent Fan Axial Bathroom/ Toilet Fan	B:9-B:10
	Lo-Carbon VA100®/SELV Axial Bathroom/Toilet Fan	B:11-B:12
	Lo-Carbon Silhouette® 100/SELV Bathroom/Toilet Fan	B:13-B:14
	Lo-Carbon Centra®/SELV dMEV Unit	B:15-B:16
	Lo-Carbon Revive/SELV Bathroom/Kitchen Filterless Fan	B:17-B:18
	Lo-Carbon Solo Plus/SELV Centrifugal Bathroom/Toilet Fan	B:19-B:20
	Lo-Carbon Minivent Ducted Bath/Shower Fan Kit	B:21
	Lo-Carbon LED Vent-A-light Ducted Bath/Shower Fan Kit	B:22
	Lo-Carbon Quadra® Centrifugal Fan	B:23-B:24
	Lo-Carbon Silhouette® 125 Bathroom/Toilet Fan	B:25
	Lo-Carbon VA150 Axial Kitchen & Utility Room Fan	B:26
	Lo-Carbon Silhouette® 150 Axial Kitchen Fan	B:27

Lo-Carbon iQ

Features & Benefits

- Minimal retro design to match bathroom décor
- Extremely quiet at only 21 dB(A)
- Truly surface mountable with removable spigots
- Intelligent controls and control panel for easy and flexible set up and commissioning
- Low power consumption - 2.1 - 5.5 Watts
- Easy cleaning and maintenance
- 5 year motor guarantee
- Intelligent humidistat control as standard
- Innovative airing function to ensure good air quality
- IP44 rated



Silent Operation

The open impellor and the unique method of operating the motor enables a greater array of operating options including silent continuous ventilation along with adaptable speed control and flexible timer functions.

Humidity Control

The iQ features an intelligent, fully automatic humidity sensor for moisture control. This means the fan learns to run only when it can make a difference to the indoor air quality. The fan continually monitors and records the moisture content to allow it to map the humidity profile throughout the year. This process enables the fan to ensure that it runs only when the fan can lower the moisture content in the air. This reduces nuisance running. The fan also has two modes for moisture control, silent or boost mode which can be selected via the touch pad control.

Control Panel

Our aim has been for the end user to be able to control and understand the basic fan functions, without the need of reading the manual. When the fan is connected to the power supply, it also performs a self-test where all the status lamps on the control panel are tested, as well as the function of the motor. Ideal for those installing to ensure that everything works. The simple controls, along with the LED feedback make the commissioning and any readjustment, quick and easy to complete.

LED Feedback

With many fans it is difficult to understand the exact mode that they are running in. We have now simplified this to provide a visual indicator to see what the fan is doing and which mode is currently active. The fan uses three different colours on the visible status lamp to communicate exactly what it is doing. A blue light signifies that the fan is working to evacuate moisture via the humidity sensor. A yellow light signifies that the timer is running. And a purple light signifies that the fully automatic airing function is active.

Choose How The Fan Works

The intelligent overrun timer can be operated in several different ways, either via the light switch, integral pull-cord or a separate switch either as a standard On/Off or as a momentary switch stopping automatically after the overrun on time. Use the control panel to easily set the required post-running time at 15 or 30 minutes, depending on the choice.

Full Surface Mounted Installation

With the impellor and motor assembly designed to be low profile and accessible for maintenance, spigots on the fan are completely removable. This design enables the fan to be mounted onto a wall without any spigot so that it can be truly surface mounted. This is an ideal function if there is a duct with a smaller dimension than 100 mm or a duct that bends directly off of the back of the fan not providing any depth in the wall for the spigot.

Cleaning and Maintenance

For a fan to ventilate effectively, it is vital that it is kept clean and that the ductwork and grilles are free from dust that can reduce the air flowing through them. This is the first fan to be introduced with the ability to simply remove the impellor and open the centre of the fan to gain free access to the duct. Using the 'swing-out' function the fan can easily be cleaned and cleared e.g. a clogged grille on the outside of the façade. Click the button to remove the impellor, then press the snap in catch and swing out the motor - that's it!

Automatic Airing Function

The airing function means when the fan has been inactive for 26 hours, it runs an airing programme for 60 minutes to exchange the air in the bathroom. No more worries about stuffy, musty odours in the bathroom when returning from holiday.

Lo-Carbon 5 Year Guarantee

As there is an integrated power adapter in the fan we have been able to use a low voltage motor that has a life span of approximately 60,000 hours. This is about 3-5 times longer than a standard fan. The motor features extremely quiet bearings. By using a low voltage motor we can significantly limit power consumption. The fan only consumes 5 Watts, about a third of a conventional AC bathroom fan.

Models

Lo-Carbon iQ

Multi control fan with option to run on intermittent or continuous setting. Adjustable timer and humidity options with integral pullcord included.

Model

Lo-Carbon iQ

Stock Ref

411409

Dimensions (mm)

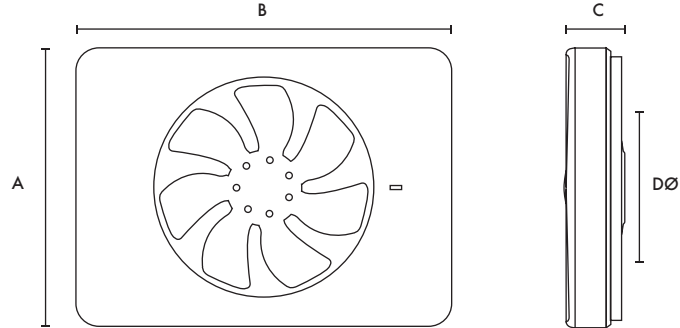

A	B	C	DØ
152	202	31	99/125

Product is supplied with a removable spigot 30mm deep in 99mmØ and 125mm Ø

Performance

Duct Ø	Trickle/Boost	Extract Performance - FID	
		m ³ /h	Sound dB(A) @ 3m
100mm	Max	107	28
100mm	Silent	74	21
100mm	Trickle	42	12
125mm	Max	134	29
125mm	Silent	86	21
125mm	Trickle	55	13

Vent-Axia PureAir Sense

- Automatic odour sensor
- 7 year warranty
- LED touch panel
- App connected
- Silent running, as low as 19dB(A)
- Low power consumption at 2.5W
- Interchangeable spigots for 100 or 125mm installations
- Easy clean with removable impeller
- Optional magnetic front cover
- IP44 Rated
- Suitable for ceiling and wall mounting



Odour Sensor

The Vent-Axia PureAir Sense is the UK's first bathroom fan with Odour Sense Technology. This technology works by detecting unwanted odours in the air and triggers a purge function to clear the air. This results in a fresh bathroom without the need to add any harmful air sprays into the atmosphere.

Silent Operation

Running from just 19dB(A), the PureAir Sense is whisper quiet. Its silent continuous operation enables the fan to keep the air quality in the room high, without disturbing the occupants.

Humidity Control

The Vent-Axia PureAir Sense features an intelligent, fully automatic humidity sensor for moisture control. The fan will boost when it senses an increase in the room's humidity, ensuring the humid air is extracted and the room remains free of condensation. The fan continually monitors the environment and records the moisture content to allow it to map the humidity profile throughout the year. This process enables the fan to ensure that it runs only when the fan can lower the moisture content in the air. This reduces nuisance running and stops the fan from boosting unnecessarily, keeping running costs down.

Touch Panel

The front of the fan includes an intuitive, easy to use LED touch panel. Users can see which fan function is active by viewing the multi-coloured LED indicator, as well as customising the fan's functions and boost speeds using the touch menu. For full description on the touch panel, please refer to the Instruction Manual provided with the fan.

Vent-Axia Connect App

All fan settings can be customised by downloading the Vent-Axia Connect App to Android and IOS devices.



Magnetic Front Cover

For the first time in any Vent-Axia product, a magnetic front cover is included with this fan. The cover is as simple as it sounds to put on with the use of four small magnets, and is designed to allow the fan to compliment any bathroom.



Adjustable Timer

The adjustable overrun timer operates automatically when installed, but can be customised using the Vent-Axia Connect App. The control panel can be used to easily set the required post-running time at 15 or 30 minutes, depending on your choice.

Cleaning and Maintenance

For a fan to ventilate effectively, it is vital that it is kept clean so that the ductwork and grilles are free from dust which can reduce the air flow. The removable impeller helps to simplify cleaning.

Automatic Airing Function

The airing function activates when the fan has been inactive for 26 hours. It runs an airing programme for 60 minutes to exchange the air in the bathroom. No more worries about stuffy, musty odours in the bathroom when returning home from time away.

Light Sensor

The Vent-Axia PureAir Sense is delivered factory set for continuous operation at low speed, with the fan featuring an adjustable timer that can be triggered via a switch live or light sensor. This intuitive light sensor recognises room occupancy through light movement and shadows, but can distinguish between car headlights flashes and people moving about to avoid nuisance running. A delay-on feature can also be set to avoid the fan being triggered in the night during quick bathroom visits. The light sensor also acts as an overrun timer, without having to be controlled through the light switch.

Models

Vent-Axia PureAir Sense

Odour Sensing fan with intelligent humidistat, adjustable timer, intermittent or continuous settings and Bluetooth app control.

Model PureAir Sense Stock Ref **479460**



Wall Mounting Back Plate

Designed to cover up marks where a previous fan has a different foot print. 242mm x 190mm.

Model Wall Mounting Back Plate Stock Ref **406762**

Accessories



Internal Fit Wall Kit

Suitable for 100mm applications

Model Internal Fit Wall Kit - White Stock Ref **474779**

Dimensions (mm)

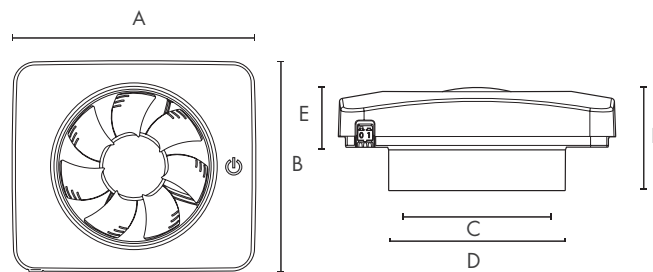

A	B	CØ	DØ	E	F
185	160	98	118	40	69

Product is supplied with a removable spigot 30mm deep for 100mmØ and 125mmØ applications. Weight 1.75kg

Performance Guide

Duct Ø	Boost/Continuous	Extract Performance - FID		Sound dB(A)	
		m³/h	l/s	@ 3m	Watts
100mm	Max	115	32	44	5
100mm	Continuous	36	10	19	2
125mm	Max	140	39	49	5
125mm	Continuous	54	15	23	2

19dB(A) at 8l/s selectable via App

Lo-Carbon Svara

- Multiple installation and commissioning options
- Set up and control through the App via Bluetooth
- Continuous or intermittent
- Removable impeller for easier cleaning and replacement
- Silent hours scheduling and purge mode functions
- Intelligent light sensor with overrun timer - allows replacement of a basic model fan
- 3 Speed, IP44 Rated, DC motor with 5 year warranty
- Suitable for ceiling, panel or wall mounting
- Only 17dB(A)
- Low running costs



Fully flexible installation and control

The launch of Svara marks the next generation of unitary fans. Home owners have complete control of their indoor air through an intuitive App designed to give them flexible options on how to run the fan. Giving home owners this control has the added benefit of removing the need for multiple returns to the property post installation should the fan not be set up quite to the householders' liking. For example the humidity setting being too sensitive. The home owner can simply log on to the App and change the setting themselves.

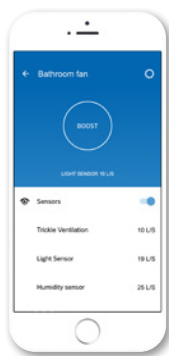

For electricians, installation is made simple through the App allowing you to choose intermittent or continuous ventilation; whether you would like the humidistat to trigger operation or not; and whether the overrun timer is required. No more fiddly switches and jumpers!



Aesthetics and Silence

The name Svara takes its influence from the fan's Swedish heritage - a country well known for iconic and well thought out designs. Consumers will be attracted to Svara's good looks with its sleek modern design, plus with noise a key issue for consumers, households will also be impressed by Svara's quiet running, operating at just 17dB(A) on low trickle. It is also easy to clean as the central module disconnects the motor from the rest of the fan allowing it to be simply wiped with a soft cloth, and at only 4W the energy efficient Svara also boasts low power consumption.

Multi Room Multi Function

Vent-Axia Svara is programmed to cope with the vast majority of installations. Because of this, it can be fitted in either a bathroom or Kitchen and can be set to run either continuously or intermittently.

Light Sensor

When the light sensor is enabled Svara senses when someone is in the room and then activates. Its sophisticated light sensor is triggered by light movement and shadows. It is possible to set a delay-on so the fan is not triggered by the light during quick night time bathroom visits. The light sensor can also distinguish between headlight flashes from cars and room occupancy, so it is not triggered by passing cars, avoiding nuisance running. The sensitivity of the light sensor can be adjusted via the App.

Overrun Timer

The light sensor provides an overrun timer but only requires a live and neutral. In houses where there is only a basic fan installed, the home owner can upgrade to a timer fan without having to rewire.

Humidistat

Svara features a humidistat which reacts to sharp changes in humidity, for instance when someone is taking a shower. When set to continuous running, once the humidity sensor is activated the fan runs at 30l/s until humidity returns to normal levels then the fan powers down to 10l/s. Ambient humidity changes will not trigger the humidistat. It is possible to change the sensitivity of the humidity sensor via the App.

Silent Scheduling and Automatic cycles

The silent hours scheduling function allows you to deactivate the boost function on the Svara via the App, for example, this would prevent nuisance noise overnight. Additionally during a vacation you can set Svara to an airing mode which operates a purge function every 12 hours for either 30, 60 or 90 minutes depending on selection. However, Svara's sophisticated controls, will not purge if the light sensor detects that there is someone in the house.

Models

Svara kitchen and bathroom fan

100 mm Axial fan. Factory set at continuous running with Humidistat and Light Sensor/overrun timer On.

Model	Stock Ref
Lo-Carbon Svara White	409802
Lo-Carbon Svara Black	496711



Model	Stock Ref
Back Draught Shutter	406605

Accessories



Model	Stock Ref
Wall Kit	254102



Model	Stock Ref
Cover plate	For duct dimensions between \varnothing 140-160mm
Cover Plate White	409820
Cover Plate Black	497117

Dimensions (mm)

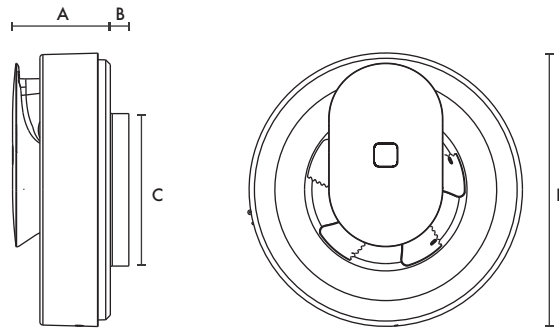

A	B	C \varnothing	D \varnothing
60	21	99	177

Performance Guide

Extract Performance - FID (l/s)				Sound dB(A)	SFP (W/l/s)
Low Trickle	High Trickle	Boost	Max Watts	@ 3m	@ 0Pa
10	16	30	4	17-20	0.13

Lo-Carbon Silent Fan

- Stylish open front models
- From only 12dB(A)
- High efficiency long life motor rated up to 40,000 hours run time
- 5 year warranty
- IPX5 - Zone 1 rated
- Meets current Building Regulations Approved Document F and L
- Extra-long duct run? Variable speed adjustment at installation allows you to get the airflow you need
- Closed or open fronted models
- Silent bathroom fan with intermittent and continuous running options
- Back draught shutters included
- Suitable for wall, ceiling, window and panel mounting



Lo-Carbon Silent Fan Axial Bathroom/Toilet Fan

The Lo-Carbon Silent Fan Range from Vent-Axia not only delivers stylish and silent ventilation without compromise on performance, but now comes with even more features and more model options providing flexibility when choosing the right fan.

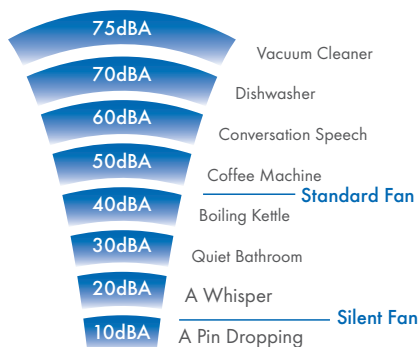

Zone 1 Variable Speed, Intermittent, Humidity Timer

Intermittent Operation. Humidity controlled with fixed 15 min timer overrun. Variable speed options selectable at install.

Model	Stock Ref
VASF100HTV (closed grille)	479087
VASF100HTVO (open grille)	495702

Zone 1 Variable Speed, Continuous, Timer

Fixed 15 min overrun timer. Continuous running fan with variable speed selectable at install.

Model	Stock Ref
VASF100TC (closed grille)	479088
VASF100TCO (open grille)	495703

Zone 1 Variable Speed, Continuous, Humidity Timer

Humidity controlled with fixed 15 min timer overrun. Continuous running fan with variable speed selectable at install.

Model	Stock Ref
VASF100HTC (closed grille)	479089
VASF100HTCO (open grille)	495704

Models

Zone 1 Variable Speed, Intermittent

Remote or light switch operation. Variable speed options selectable at install. Intermittent operation.

Model	Stock Ref
VASF100BV (closed grille)	479085
VASF100BVO (open grille)	495700

Zone 1 Variable Speed, Intermittent, Timer

Intermittent Operation. Fixed 15 min overrun timer. Variable speed options selectable at install.

Model	Stock Ref
VASF100TV (closed grille)	479086
VASF100TVO (open grille)	495701

Accessories

Model	Stock Ref
Window Kit	442947
Wall Kit White	254102
Wall Kit Brown	254100
Internal Fit Wall Kit White + Backdraught Shutter	474779

Dimensions (mm)

Closed Grille

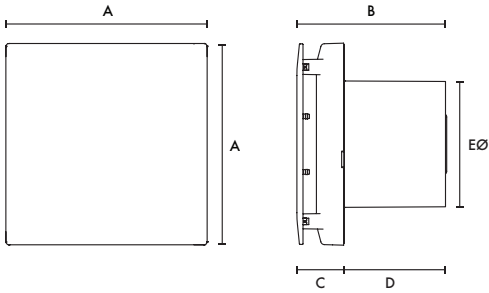

Open Grille

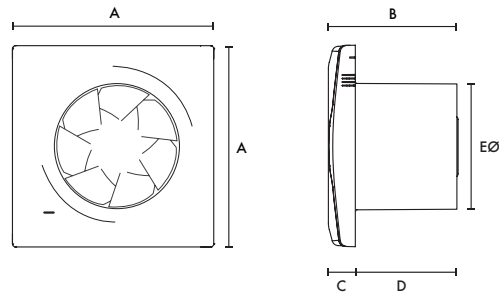

Grille	A	B	C	D	EØ
Closed	160	117	37	80	99
Open	160	117	22	80	99

Weight 0.7kg

Performance Guide

Closed Grille

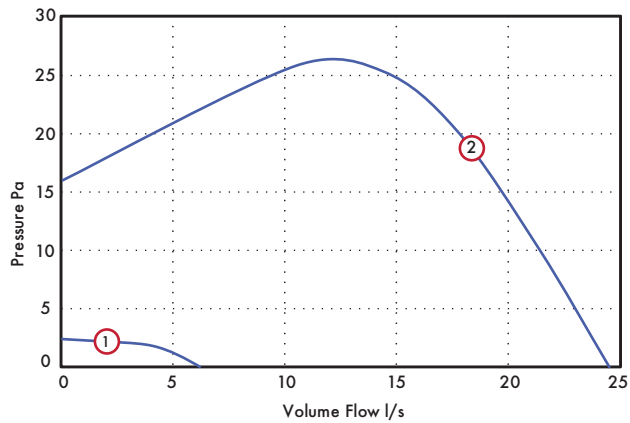

Open Grille

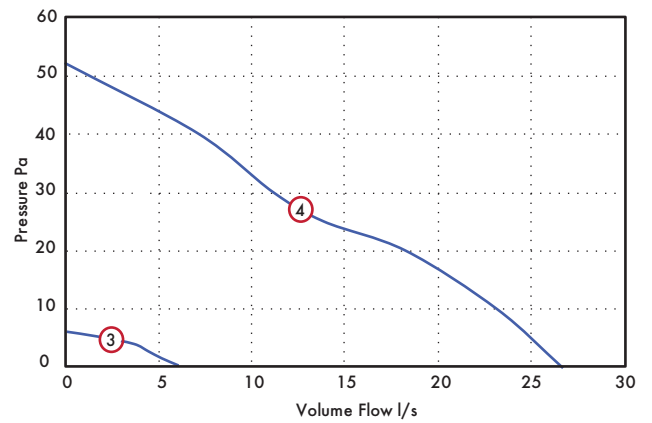

	Model	Speed	l/s	Watts	Warranty (years)
Variable Speed	VASF100BV/ TV/HTV	① Min	6	1.7	5
		② Max	24	7.5	
	VASF100TC/ HTC	Adjustable	6 - 15	1.7 - 7.5	5
		Trickle			
		Boost	Adjustable Trickle + 10 (Up to a max of 22 installed)	7.5	

12dB(A) - Sound dB(A) @3m at low speed

	Model	Speed	l/s	Watts	Warranty (years)
Variable Speed	VASF100BVO/ TVO/HTVO	③ Min	6	1.7	5
		④ Max	27	7.5	
	VASF100T- CO/HTCO	Adjustable	6 - 19	1.7 - 7.5	5
		Trickle			
		Boost	Adjustable Trickle + 10 (Up to a max of 22 installed)	7.5	

12dB(A) - Sound dB(A) @3m at low speed

Lo-Carbon VA100/SELV

- Meets current Building Regulations Approved Document F & L
- Suitable for wall, ceiling, panel and window mounting
- Fitted with a motorised shutter
- Protected against low energy lighting circuits
- IPX4 rated - IPX7 rated (SELV)
- Efficient long life DC motor with 5 year warranty
- Uses up to 87% less energy
- Low sound levels
- 1 of 2 speeds selectable at installation
- Low specific fan power



Long Life Ventilation VA100

The Vent-Axia Lo-Carbon VA100 range features Lo-Carbon long life DC motors that are more efficient than conventional motors delivering up to 87% energy savings.

Shutters

The Vent-Axia Lo-Carbon VA100 range is fitted with a motorised shutter mechanism that uses no extra power in operation or off.

Installation

Fitted with integral protection against low energy lighting circuits, the Lo-Carbon VA100 is a 100mm axial fan suitable for use in the bathroom or toilet. VA100 is quick and simple to fit with easy-wire in one line terminals. Suitable for installation in windows, walls or panels/ceilings using kits available. The 100mm telescopic wall kit fits walls 225 to 360mm thick. The range meets the requirements of the current Building Regulations for the ventilation of toilets 6l/s and bathrooms 15l/s with a 15 minute overrun timer for internal rooms on the LT, XT and HTP models.

Safety Extra Low Voltage (SELV) Fan

Safety Extra Low Voltage (SELV) is designed for areas where a fan has to be fitted within zone 1 in a room containing a fixed bath or shower according to IEE wiring regulations. The VA100 SELV can be safely installed within the spray area. The fan is rated IPX7, control is by the supplied mains safety isolating transformer with 12V DC SELV output, which is sited away from any source of spray and out of reach of a person using a fixed bath or shower.

Models

Lo-Carbon VA100 LP/SELV LP (Pullcord)

Ultra long life DC motor. Pullcord On/Off override switch with indication light. 2 speed options.

Model	Stock Ref
LP	443159
SELV LP	441614

Lo-Carbon VA100 XP/SELV XP (Shutter/Pullcord)

Ultra long life DC motor. Pullcord and On/Off override switch with indication light. 2 speed options.

Model	Stock Ref
XP	443160
SELV XP	459049

Lo-Carbon VA100 LT/SELV LT (Timer)

Electronic adjustable overrun timer (5-30 minutes). Indication light. 2 speed options.

Model	Stock Ref
LT	443161
SELV LT	441615

Lo-Carbon VA100 XT/SELV XT (Shutter/Timer)

Integral electronic adjustable overrun timer (5-30 minutes). Indication light. 2 speed options.

Model	Stock Ref
XT	443162
SELV XT	459050

Lo-Carbon VA100 LHTP/SELV LHTP (Integral Humidity Sensor/Pullcord/Timer)

Complete with integral humidity control with pullcord override. Indication light which operates on the manual override only. 2 speed options.

Model	Stock Ref
LHTP	443163
SELV LHTP	441616

Lo-Carbon VA100 XHTP/SELV XHTP (Shutter/Integral Humidity Sensor/Pullcord/Timer)

Complete with integral humidity control with pullcord override. Indication light which operates on the manual override only. IPX4 rated. 2 speed options.

Model	Stock Ref
XHTP	443164
SELV XHTP	436064

Accessories

Wall Kit

Fixing hole diameter 117mmØ

Model	Stock Ref
Wall Kit White	254102
Wall Kit Brown	254100

Window Kit

Fixing hole diameter 105mmØ

Model	Stock Ref
Window Kit	254101
Anti-tamper Window Kit	443234

Dimensions (mm)

Panel

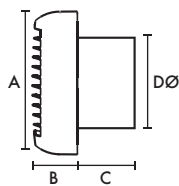
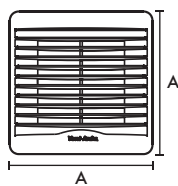

Wall

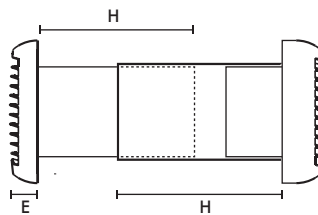

Window

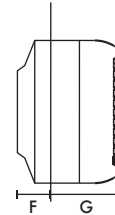

Area	A	B	C	DØ	E	F	G	H
Bathroom/Toilet	146	47	53	98	31	31	74	200

SELV Transformer (W x H x D) 87 x 87 x 33

Weight 1 kg

Performance

Area	Models	Extract Performance - FID			Sound dB(A)	SFP (W/l/s)
		m ³ /h	l/s	Watts	@ 3m	@ 0Pa
Toilet	Lo-Carbon VA100/SELV LP/XP/LHTP/XHTP/LT/XT	60	17	3.4	32	0.20
Bathroom	Lo-Carbon VA100/SELV LP/XP/LHTP/XHTP/LT/XT	74	21	7.0	36	0.33

Lo-Carbon Silhouette 100/SELV

- Models Basic/Timer/Humidity & Timer
- Low power consumption - Lower running costs
- Fully opening and closing non-transparent shutters - Improved insulation and privacy
- Meets current Building Regulations Approved Document F & L
- 1 of 2 speeds selectable at installation
- Blue power indication light (except B model) - Modern aesthetics
- Ball bearing motors for vertical or horizontal application
- Unique humidity sensor track - Improved response
- 5 year motor warranty
- IPX4 rated - IPX7 rated (SELV)
- Suitable for wall, ceiling, panel and window mounting



Slimline Bathroom Ventilation

With a slim profile of only 17mm, Lo-Carbon Silhouette blends in with the wall surface to provide an unobtrusive installation. Lo-Carbon Silhouette has an FID performance of up to 30l/s. It can be ceiling/panel mounted and connected to an appropriate duct run to the outside.

Safety Extra Low Voltage (SELV) Fan

Safety Extra Low Voltage (SELV) is designed for areas where a fan has to be fitted within zone 1 in a room containing a fixed bath or shower according to IEE wiring regulations. The Silhouette SELV can be safely installed within the spray area. The Silhouette SELV, control is by the supplied mains safety isolating transformer with 12V DC SELV output, which is sited away from any source of spray and out of reach of a person using a fixed bath or shower. SELV transformer to BS EN 60742.

Models

Lo-Carbon Silhouette 100B/SELV 100SVB

100mm bathroom/toilet fan with back draught shutter.

Model	Stock Ref
100B	441624
SELV 100SVB	441511

Lo-Carbon Silhouette 100T/ SELV 100SVT (Timer)

100mm bathroom/toilet fan with integral adjustable electronic overrun timer (5-30 minutes), indicator light which operates on manual override only, and back draught shutter.

Model	Stock Ref
100T	441625
SELV 100SVT	441512

Lo-Carbon Silhouette 100HT (Humidistat/Timer)

100mm bathroom/toilet fan with adjustable auto humidity sensor from 60-90% RH and overrun timer, indicator light which operates on manual override only, and back draught shutter.

Model	Stock Ref
100HT	441626

Lo-Carbon Silhouette 100H SELV (Humidistat)

100mm bathroom/toilet fan with ambient response humidity sensor from 60-90% RH, indicator light which operates on manual override only, and back draught shutter.

Safety Extra Low Voltage version.

Model	Stock Ref
SELV 100SVH	441513

Accessories

Wall Kit

Fixing hole diameter 117mmØ

Model	Stock Ref
Wall Kit White	254102
Wall Kit Brown	254100

Window Kit

Fixing hole diameter 117mmØ

Model	Stock Ref
Window Kit	442947



17mm actual profile

Dimensions (mm)

Panel

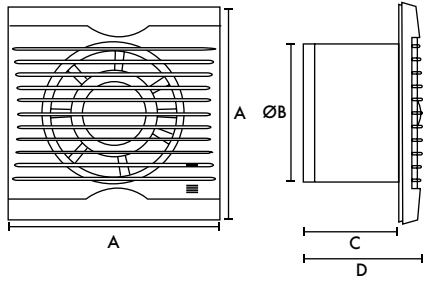

Wall Kit

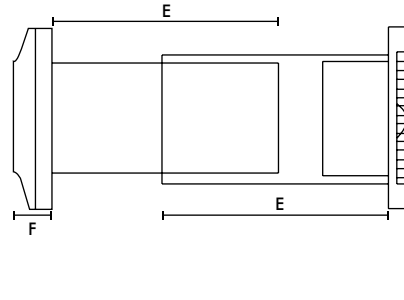

A	BØ	C	D	E	F
160	99	115	132	200	32

SELV Transformer (W X H X D) 87 X 87 X 33

Weight 0.6kg

Performance Guide

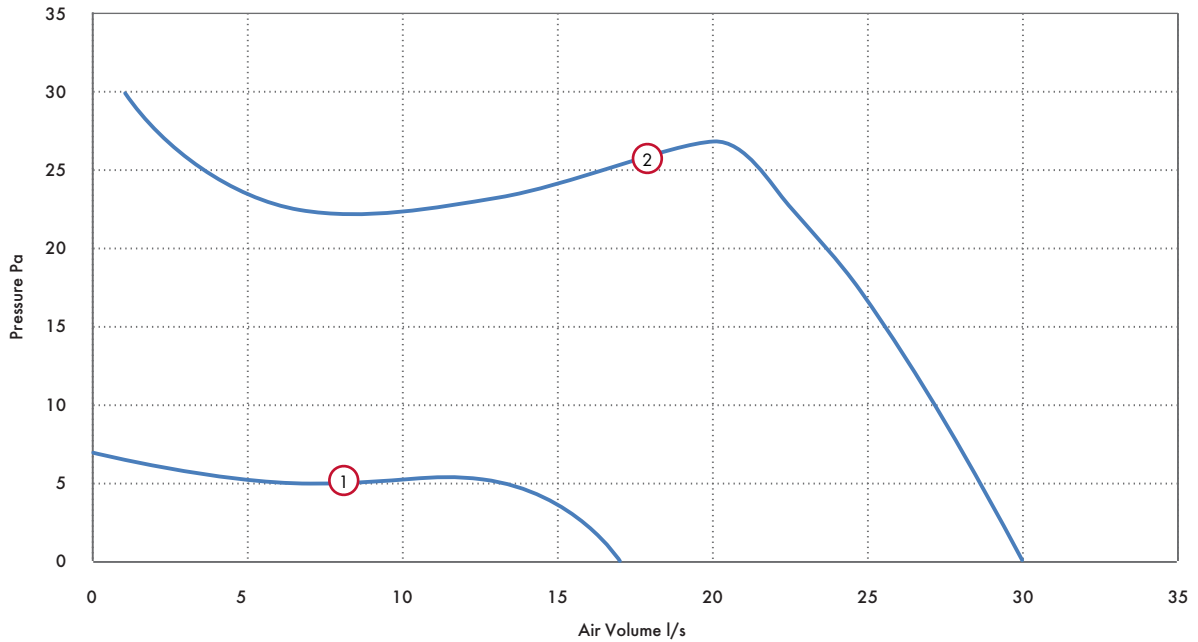

Area	Model	Curve Ref	Extract Performance - FID			Sound dB(A)	SFP (W/l/s)
			m ³ /h	l/s	Watts	@ 3m	@ OPa
Toilet	Lo-Carbon Silhouette 100 B/T/HT/SVB/SVT/SVH	1	60	17	3.4	34	0.20
Bathrooms		2	108	30	8.7	38	0.30

For window mounting: shutter cannot be used and must be removed

Lo-Carbon Centra/SELV

- Building Regulations Approved Documents F and L compliant
- Continuous mechanical extract
- Recognised in SAP PCDB - Low SFP
- Discreet, tasteful styling
- IPX4 rated - IPX7 rated (SELV)
- dMEV Pressure detection device
- 5 year motor warranty
- Suitable for wall, ceiling, panel and window mounting
- SELV models supplied with remote transformer and suitable for 'Zone 1'



the ELECTRICAL
industry awards
WINNER 2011

Winners of the Energy Efficiency Initiative 2011 Award
with our Lo-Carbon Continuous Ventilation Product Range

What is de-centralised MEV (dMEV)?

Building Regulations Approved Document F gives examples of three main methods of ventilation. Continuous mechanical extract ventilation, can be achieved using a single centralised extract unit such as the Sentinel Multivent ducted to 'wet' rooms (kitchen, bathroom, en-suite and WC) or by decentralised individual fans, such as the Lo-Carbon Centra in the 'wet' rooms. The fans run continuously at near silent levels providing a simple and effective form of ventilation.

SELV (Safety Extra Low Voltage) is designed for areas where a fan can be installed within Zone 1 in a room where there is a fixed bath or shower. Ingress Protected (IP) to IPX7 Lo-Carbon Centra SELV can be fitted safely within the spray area. The separate transformer can be mounted away from the spray zone and out of reach from the bath or shower.

The Lo-Carbon Centra meets the latest requirements of the Building Regulations Approved Document F for wholehouse system ventilation and all models come with a 5 year motor warranty.

Selection of the two trickle flow rates (6l/s or 9l/s) is via a simple 'jumper' on the control board. Different methods are available for operating the 15 l/s boost speed from a simple switched live to integral humidistat. See individual models for further details.

The attractive and discreet styling of the Vent-Axia Lo-Carbon Centra will complement the décor of any new home while virtually silent operation ensures optimum ventilation is achieved without intrusive noise.

Specific Fan Power

dMEV version recognised in SAP PCDB. Lo-Carbon Centra has a specific fan power of only 0.18 W/l/s in through-the-wall kitchen applications.

Models

Lo-Carbon Centra dMEV

Auto speed selection at installation and suitable for bathrooms or kitchens. The integral air pressure sensor checks the airflow when first installed and also helps the fan to compensate for external wind pressure.

Stock Ref

441782

Lo-Carbon Centra T/SELV T (Timer)

Ideal for bathroom and toilet applications, this unit runs continuously on trickle setting and may be boosted by the switched live input which activates the timer (fixed 15 min on T models, adjustable 5-30 minutes on SELV models).

Model

Stock Ref

T

473825

SELV T

443175

Lo-Carbon Centra TP/SELV TP (Timer/Pullcord)

For bathroom/toilet applications, the continuous running TP model is boosted by the pullcord which activates the timer (fixed 15 min on TP models, adjustable 5-30 minutes on SELV models).

Model

Stock Ref

TP

473826

SELV TP

447128

Lo-Carbon Centra HT/SELV HT (Humidistat/Timer)

For bathroom/toilet applications, the continuous running HT model is automatically boosted by the built-in humidistat or by a switched live input which activates the timer (fixed 15 min on HP models, adjustable 5-30 minutes on SELV models).

Model

Stock Ref

HT

473827

SELV HT

443176

Lo-Carbon Centra HTP/SELV HTP (Humidistat/Timer/Pullcord)

For bathroom/toilet applications, the continuous running HTP model is automatically boosted by the built-in humidistat or by the pullcord which activates the timer (fixed 15 min on HTP models, adjustable 5-30 minutes on SELV models).

Model	Stock Ref
HTP	473828
SELV HTP	443177

Dimensions (mm)

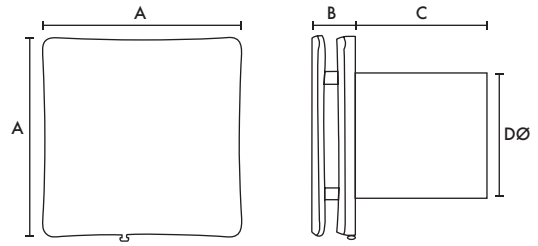

Model	A	B	C	DØ
Lo-Carbon Centra dMEV/All SELV	160	35	115	99
Lo-Carbon Centra T/TP/HT/HTP	160	35	115	99

Transformer 87 x 87 x 33mm (W x H x D) (SELV models only)

Accessories

Model	Stock Ref
150mm Conversion Kit	443334
Wall Kit White	254102
Wall Kit Brown	254100
Window Kit	442947
Ceiling Kit	443800

Performance Guide

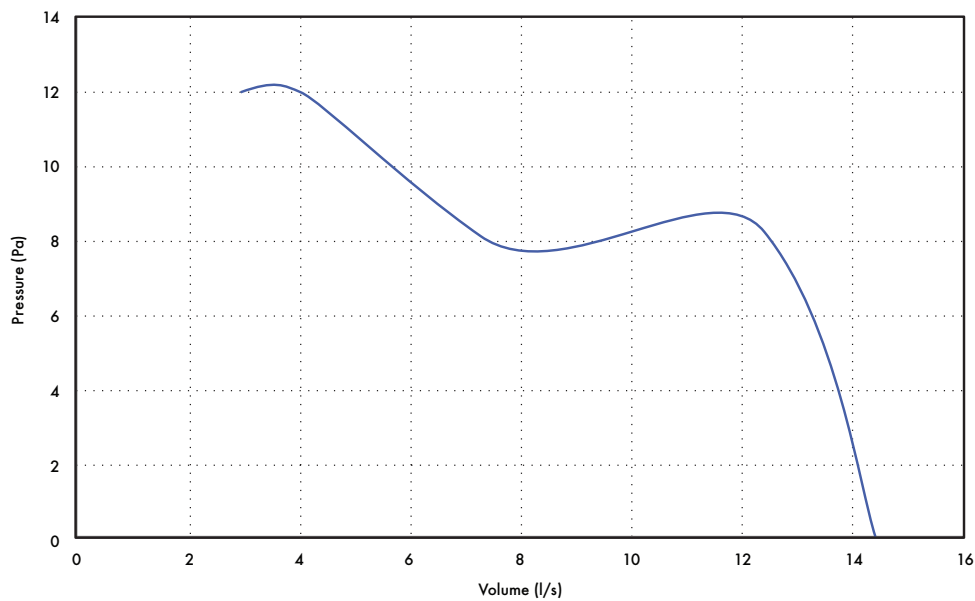

Model	Extract Performance (l/s)			Power Consumption (Watts)			Sound dB(A)@ 3m		
	Trickle	Trickle	Boost	Trickle	Trickle	Boost	Trickle	Trickle	Boost
	Low	High		Low	High		Low	High	
Lo-Carbon Centra dMEV/All SELV	6	9	15	1.4	1.6	2.4	10.8	15.5	25.2
Lo-Carbon Centra T/TP/HT/HTP	6	9	15	3.2	3.5	4.2	10.8	15.5	25.2

SAP PCDB Performance (dMEV model)

Systems With Rigid Ductwork Installation

Unit Configuration	Location	Fan Speed Setting	Flow Rate (l/s)	SFP (W/l/s)
In Room (Ducted)	Kitchen	High	13.2	0.32
In Room (Ducted)	Wet Room	9 l/s	8.4	0.28
Through Wall	Kitchen	High	13.5	0.18
Through Wall	Wet Room	9 l/s	8.6	0.20

Systems With Flexible Or Mixed Ductwork Installation

Unit Configuration	Location	Fan Speed Setting	Flow Rate (l/s)	SFP (W/l/s)
In Room (Ducted)	Kitchen	High	13.2	0.37
In Room (Ducted)	Wet Room	9 l/s	8.6	0.31
Through Wall	Kitchen	High	13.5	0.18
Through Wall	Wet Room	9 l/s	8.6	0.20

Lo-Carbon Revive/SELV

- Designed to exceed the needs of Social Housing
- Continuous running bathroom and kitchen fan
- 5 or 7 year warranty options
- High performance on trickle to avoid going to boost too often
- Intelligent Smart Sense™ data logging technology tells you days run, boost hours run, energy used
- Innovative Multi-Vortex technology ensures high performance but low sound and energy levels
- Small footprint with optional decoration frame
- Unique settings lock to prevent tampering



Designed for Social Housing

The award winning, intelligent Lo-Carbon Revive is a new filter-less unitary fan designed to meet the specific needs of social housing. Boasting powerful, quiet, efficient ventilation, Revive provides good indoor air quality and comfort for residents while being quick and easy to install, low maintenance and reliable.

Smart Sense™ Technology

Featuring Smart Sense™ intelligent technology Revive is quick and easy to install due to its simple alpha numeric LED display which is clear, easy to read and has a three-button menu for commissioning and data gathering. Smart Sense™ technology even tells the LED display which orientation to use depending on whether it is wall or ceiling mounted. All of which saves time on site and reduces installation complications. The Revive is the only fan in the market with a unique setting lock to prevent tampering with the unit giving the landlords peace of mind.

The display also shows real-time data so landlords can reassure residents of the low-running costs. This includes data such as days run, hours on trickle or boost, and even more specifically, hours run on boost triggered by the humidity sensor. Revive can also tell you how much energy the fan has used.

Multi-Vortex™ Technology

Revive is low maintenance since its market-leading Multi-Vortex™ technology does not require a filter, while the highly sculpted interior actively repels dust, avoiding clogging, thus helping to avoid call backs. In addition the Multi-Vortex™ technology has a high-pressure hybrid impeller that is powerful and efficient, yet quiet – everything you need for the Social Housing resident.

Multiple configuration options

Revive can extract up to 60l/s from a kitchen - just two fans can exceed Part F rates for a 4-bed house. Upon installation you have the choice to change the setting to allow for installation in a bathroom. The installer can also select a ducted mode or a through the wall mode. All selected via the intuitive LED display.

Intelligent Humidity Sensing and Controls

It is essential to capture moisture at the source before it can migrate to the rest of the property. However over-ventilating with crude humidity controls can cause excessive noise and discomfort to the resident. The Lo-Carbon Revive range utilises advanced humidity controls which boost in line with the detected humidity levels and whether they are rising or declining. This allows it to effectively deal with moisture, while minimising noise.

Models



Lo-Carbon Revive 7/SELV 7

A universal kitchen or bathroom HTP fan with options to be continuous running or intermittent. Adjustable trickle speed between 6-13l/s and boost speeds of 15, 30 and 60. Day logger and power run meter as standard. 7 year warranty. Built-in lock function. Adjustable dynamic ambient response humidity sensor. Timer adjustable between 1 and 30 minutes. In built boost activated by pullcord, humidity sensor, switched live or remote button. Tile front for discreet installation.

Model	Stock Ref
Lo-Carbon Revive 7	473848
Lo-Carbon Revive SELV 7	473849



Lo-Carbon Revive 5/SELV 5

A universal kitchen or bathroom HTP fan with options to be continuous running or intermittent. Adjustable trickle speed between 6-13l/s and boost speeds of 15, 30 and 60. Day logger and power run meter as standard. 5 year warranty. Built-in lock function. Adjustable dynamic ambient response humidity sensor. Timer adjustable between 1 and 30 minutes. In built boost activated by pullcord, humidity sensor, switched live or remote button. Open front grille.

Model	Stock Ref
Lo-Carbon Revive 5	473850
Lo-Carbon Revive SELV 5	473851



Lo-Carbon Revive/SELV

A universal kitchen or bathroom HTP fan with options to be continuous running or intermittent. Adjustable trickle speed between 6-13l/s and boost speeds of 15, 30 and 60. 5 year warranty. Adjustable dynamic ambient response humidity sensor. Timer adjustable between 1 and 30 minutes. In built boost activated by pullcord, humidity sensor, switched live or remote button. Open front grille.

Model	Stock Ref
Lo-Carbon Revive	473852
Lo-Carbon Revive SELV	473853

Accessories

Model	Stock Ref
Wall Kit White	254102
Wall Kit Brown	254100
Conversion Kit	408680
Ceiling Kit	407928
Window Kit	407927
Decoration Frame	474041

Dimensions (mm)

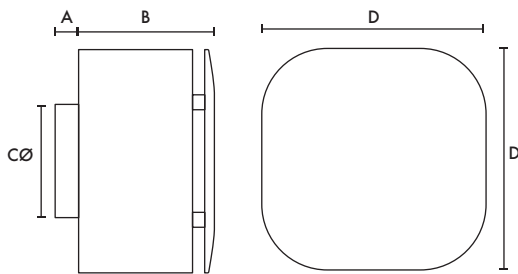

A	B*	CØ	D
30	132/102	99	193

*Closed/Open Grille

Decoration Frame Dimensions (mm)

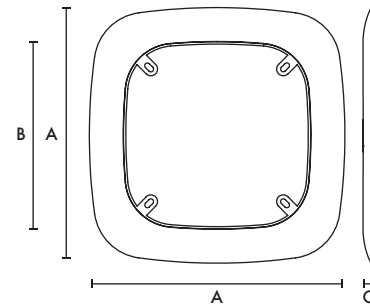

A	B	C
259	191	10

Performance Guide

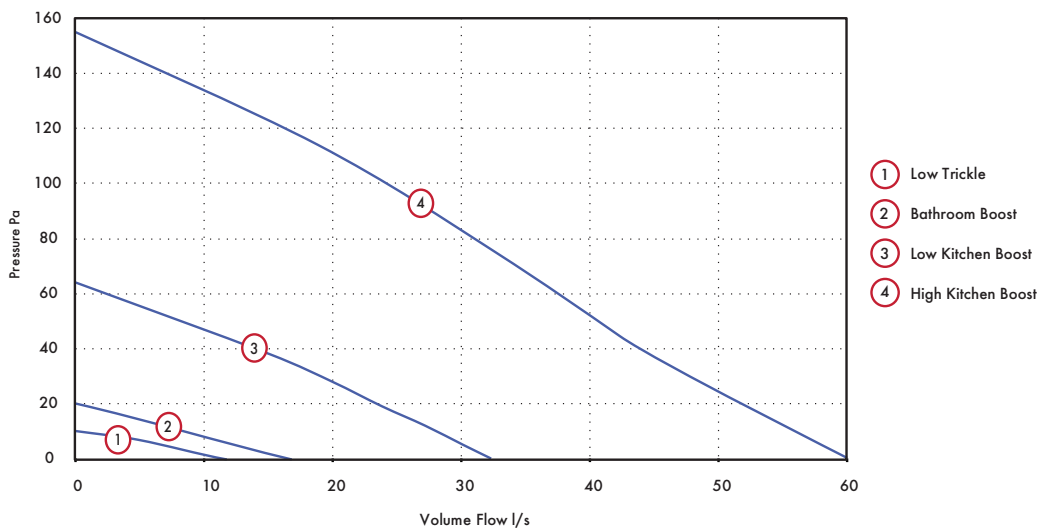

Model	Trickle Low	Extract Performance (l/s)			Trickle Low	Power Consumption (Watts)			Trickle Low	Sound Data (dB(A))		
		Bathroom Boost	Low Kitchen Boost	High Kitchen Boost		Bathroom Boost	Low Kitchen Boost	High Kitchen Boost		Bathroom Boost	Low Kitchen Boost	High Kitchen Boost
Revive	9	15	30	60	1.4	2	6	26	15	21	33	47

Lo-Carbon Solo Plus/SELV

- Up to 70% energy saving
- Filterless as standard - innovative impeller design means no need for a filter
- 5 year Lo-Carbon motor warranty
- Meets current Building Regulations Approved Documents F & L
- IPX4 rated - IPX7 rated (SELV)
- Flush or surface mountable with adjustable rear or side exit spigot
- SELV models suitable for installation over or within reach of a shower or bath
- Extremely low sound levels
- Suitable for wall, ceiling and panel mounting
- SELV Models - Supplied with a remote transformer



Long Life Ventilation

The Lo-Carbon Solo Plus range from Vent-Axia has been specially designed for through the wall and ducted applications, suitable for internal bathrooms, toilets and other small rooms. Finished in white, the Lo-Carbon Solo Plus can be flush or surface mounted, with a 2 position 100mm circular spigot for rear entry or connecting to a vertical ducting system. The powerful centrifugal impeller allows installations using 100mm ducting in straight runs, whilst still achieving 15l/s as required by Building Regulations Approved Document F.

Continuous running products, such as the Lo-Carbon Solo Plus, installed in all wet areas of a dwelling are classed as a wholehouse ventilation system and therefore only need to move the amount of air as outlined in table 5.1a and 5.1b of Building Regulations Approved Document F.

The Lo-Carbon Solo Plus has an adjustable boost speed which is set at installation variable between a wall or duct setting for boost/override operation to meet Building Regulations thus ensuring minimum energy usage and low sound levels. All models have an optional speed for constant trickle ventilation (12l/s), selectable at installation. Depending on the model, the fan will switch from trickle (if selected) to boost via the pullcord/light switch/humidity sensor/PIR.

All models can be wall, panel or ceiling mounted and can be connected to either circular, rectangular or Vent-Axia's flat ducting. Enclosure of the electrical components is manufactured from flame retardant grade material.

Safety Extra Low Voltage Fan (SELV)

Designed for areas where a fan has to be fitted over or within Zone 1 in a room containing a fixed bath or shower according to IEE wiring regulations (BS 7671), the Lo-Carbon Solo Plus SELV fan can be safely installed within the spray area. The fan is rated IPX7. Control is by the supplied mains safety isolating transformer unit with 12V DC SELV output, which is sited away from any source of spray and out of reach of a person using a fixed bath or shower. Controller Supply voltage 220-240V/1/50Hz. Output to fan SELV 12V DC.

Models

Lo-Carbon Solo Plus P/SELV P (Pullcord)

Flush or surface mountable. Control by Pullcord. 2 Speed. Constant trickle option. Adjustable boost. In-built Lo-Carbon controller.

Model	Stock Ref
P	427481
SELV P	427485

Lo-Carbon Solo Plus T/SELV T (Timer)

Flush or surface mountable. Control by room light or switch. 2 Speed. Constant trickle option. Adjustable boost. Adjustable timer overrun. Delay on timer. In-built Lo-Carbon controller.

Model	Stock Ref
T	427482
SELV T	427486

Lo-Carbon Solo Plus HT/SELV HT (Humidistat/Timer)

Flush or surface mountable. Humidity controlled fan with override pullcord. Constant trickle option. Adjustable boost. Adjustable timer overrun. Delay on timer. Adjustable humidity sensor. In-built Lo-Carbon controller. Datalogger as standard on all Lo-Carbon humidity controlled Solo Plus fans.

Model	Stock Ref
HT	427483
SELV HT	427487

Lo-Carbon Solo Plus TM/SELV TM (Timer/PIR)

Flush or surface mountable. Control by integral PIR detector. 2 Speed. Constant trickle option. Adjustable boost. In-built Lo-Carbon controller.

Model	Stock Ref
TM	427484
SELV TM	427488

Accessories

Lo-Carbon Solo Plus Bezel

Used when flush mounting - reduces the need to make good.

Model Stock Ref
 Bezel 404106

Model Stock Ref
 Wall Kit White 254102
 Wall Kit Brown 254100

Filter Pack (1 per pack)

The design of the Lo-Carbon Solo Plus means that it does not need a filter. However, if you are going to install the product in a heavily greasy environment, you may want to protect the product by fitting a filter.

Model Stock Ref
 Filter Pack 449265

Dimensions (mm)

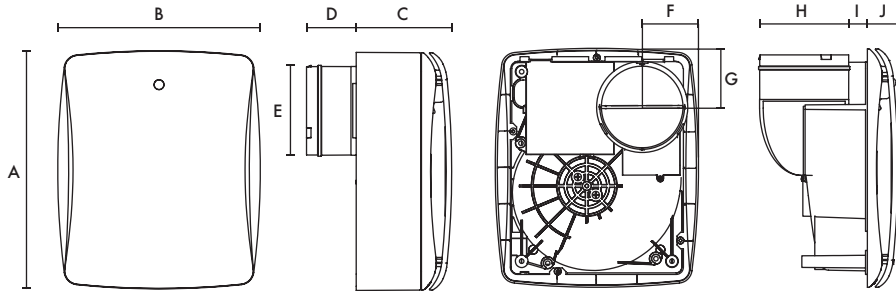

A	B	C	D	EØ	F	G	H	I	J
263	224	106	55	98	62	65	98	21	34

Weight 2.2kg, SELV Weight 2.7kg. Dimensions: (W x H x D) 87x87x33mm.

Performance Guide (Duct Mode)

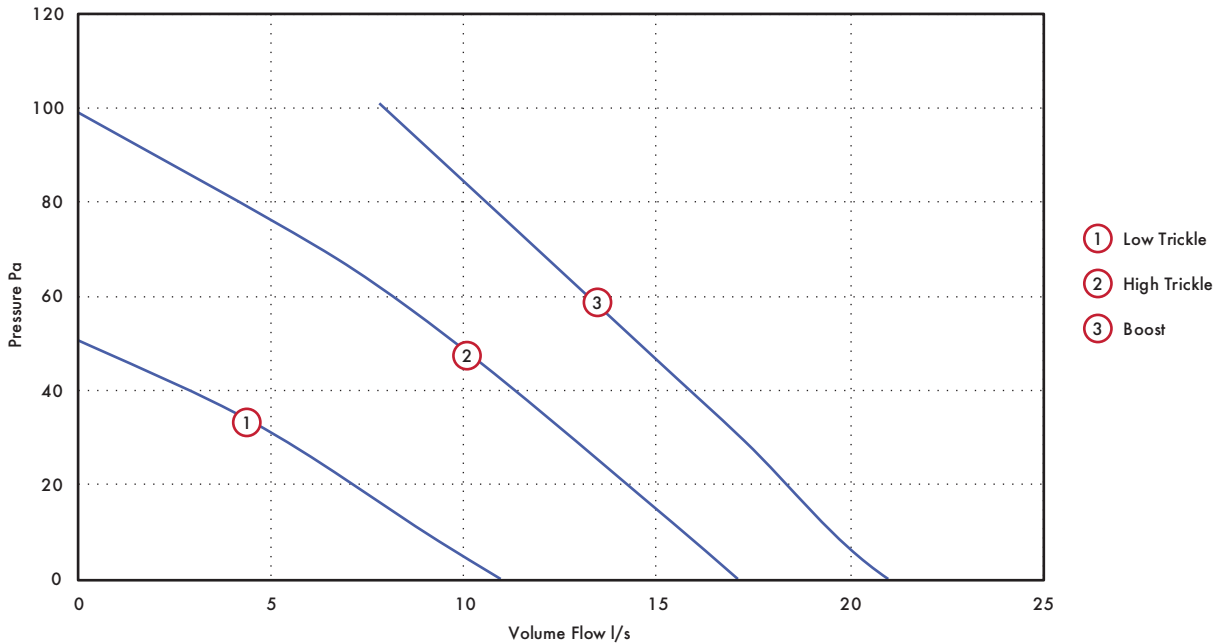

Model		Extract Performance l/s (m³/h)			Power consumption - Watts			dB(A) @ 3m			SFP (W/l/s) @ 0Pa
		Boost	High trickle	Low Trickle	Boost	High trickle	Low Trickle	Boost	High trickle	Low Trickle	
Lo-Carbon Solo Plus/SELV P/T/HT/TM	Wall mode	18 (64.8)	12 (43.2)	8 (28.8)	6	2.9	2.3	33.5	27	23.5	0.28
	Duct mode	21 (75.6)	17 (61.2)	11 (39.6)	8.4	5.3	3.2	35.5	33	26	0.29

Tested at 240VAC @ 50Hz

Lo-Carbon Minivent

- Complete kit supplied
- Meets Building Regulations Approved Document F & L requirements for toilets and bathrooms at max 1.5m of ducting and 1x 90° bend
- Adjustable timer version available
- 5 year Motor Warranty
- 1 of 2 speeds selectable at installation



Powerful Lo-Carbon In-Line Fan Kit

The Vent-Axia Lo-Carbon Minivent ducted bath/shower kit includes all the components necessary to install a ducted 100mm system. This simplifies fitting of an efficient ventilation system to small rooms including bathrooms, shower rooms and toilets. It is especially suitable for en-suite bathrooms.

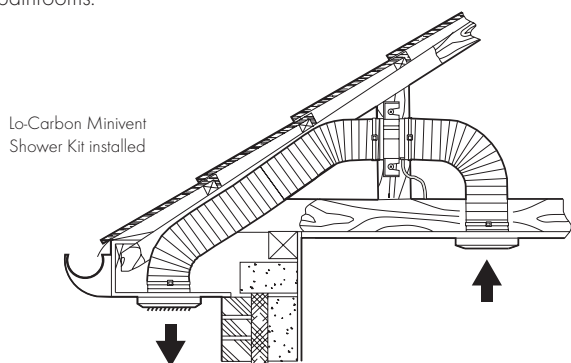

When installed, the fan kit has ample performance to meet the Building Regulations requirements for toilets and bathrooms. The timer version should be used for internal rooms.

The kit consists of a Lo-Carbon Minivent In-Line fan, a white ceiling grille and spigot, 3 metres of flexible duct and an external louvre for soffit or wall mounting. The duct should be cut to the required length and the bend radius kept to a maximum to provide optimum fan performance.

Enclosed terminal compartment, Class 2 appliance. Supply voltage 220-240/1/50Hz.

Models

Lo-Carbon Minivent Shower Fan (Basic)

Comprises - high output tube fan, 3 metres of flexible duct, ceiling inlet grille and spigot, soffit/wall outlet grille.

Model Stock Ref
Basic 441421

Lo-Carbon Minivent Shower Fan (Timer)

Comprises high output tube fan, 3 metres of flexible duct, ceiling inlet grille and spigot, soffit/wall outlet grille.

Model Stock Ref
Timer 441422

Dimensions (mm)

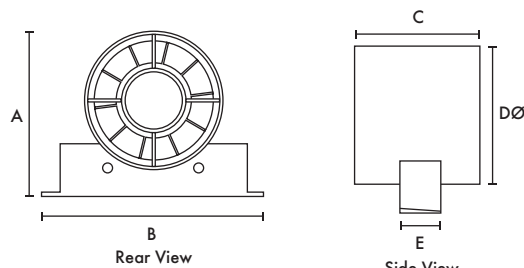

A	B	C	DØ	E
130	155	90	98	27

Internal/External Grille Dimensions 140x140mm

Transformer (W x H x D) 87 x 87 x 33

Performance Guide

Model	Extract performance			Sound dB(A) @ 3m	SFP (W/l/s) @ OPa
	FID m ³ /h	l/s	Watts		
Lo-Carbon Minivent B/T	110	31	6.5	23	0.21

Lo-Carbon LED Vent-A-Light

- Suitable for shower enclosure and wet areas
- 3W LED Lamp
- Provides simultaneous fan and light operation
- Meets current Building Regulations Approved Documents F & L
- 1 of 2 speeds selectable at installation
- Double insulated fan
- Light assembly Class III
- 5 year Motor Warranty
- Supplied with white and chrome bezels



100mm Lo-Carbon axial in-line shower fan and light kit. Provides simultaneous fan and light operation. Suitable for shower enclosures and wet areas. Available with both a white and chrome bezel on light assembly. The light assembly can be held in place using fixing clips or screws.

Typical Specification

CE marked in accordance with all the relevant EEC Harmonised Directives.

Fan double insulated and the motor is fitted with Thermal Protection. Light assembly class III.

Electrical

12 volt DC 3W GU5.3 sealed lamp. Powered by an LED Driver.

LED lamp lumens output 180lm - 200lm

Input, AC. Output - 12 volt DC. 1A.

Models

Lo-Carbon Vent-A-Light Fan and LED Light Kit (Basic)

100mm axial in-line shower fan and light kit. Includes fan, 3m flexible ducting, white grille, LED lamp light transformer and light assembly with white and chrome bezels.

Model Stock Ref
Basic 441423

Lo-Carbon Vent-A-Light Fan and LED Light Kit (Timer)

100mm axial in-line shower fan and light kit. Fan has electronic overrun timer adjustable from 5 to 30 minutes. The factory setting is 15 minutes. Includes fan, 3m flexible ducting, white grille, LED lamp light transformer and light assembly with white and chrome bezels.

Model Stock Ref
Timer 441424

Dimensions (mm)

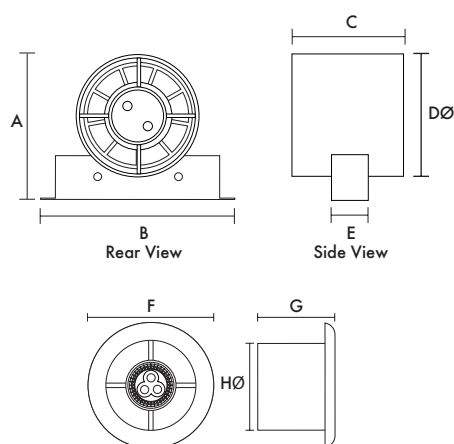

A	B	C	DØ	E	FØ	G	HØ
130	155	90	98	27	140	74	98

Internal/External Grille Dimensions 140x140mm

Fan Transformer (W x H x D) 87 x 87 x 33

Performance Guide

Model	Extract performance - FID		Fan Watts	Light Watts	Sound dB(A) @ 3m	SFP (W/l/s) @ 0Pa
	m ³ /h	l/s				
Lo-Carbon Vent-A-Light B/T	110	31	6.5	3	23	0.21

Tested at 240V 50Hz

Lo-Carbon Quadra

- Meets current Building Regulations Approved Document F & L for intermittent or continuous use
- Recognised in SAP PCDB - Low SFP on PCDB 0.38 W/l/s
- 100mm circular spigot for easy installation and replacement of any existing fan - flush or surface mount
- Filterless technology and maintenance free
- Lo-Carbon motors offering 90% energy savings and long life
- Motor cassette cartridge for simple replacement
- 5 year Motor Warranty
- IPX4 rated
- Suitable for wall, ceiling and panel mounting



the **ELECTRICAL**
industry awards
WINNER 2011

Winners of the Energy Efficiency Initiative 2011 Award
with our Lo-Carbon Continuous Ventilation Product Range.

Ventilation for any room

The Lo-Carbon Quadra offers a single fan suitable for surface or flush mounting. Low speed selectable between 6, 9 and 12l/s and high between 15, 30 and 60l/s all with through the wall or two ducted selections to ensure installed performance is met.

Discrete

With discrete aesthetics and low noise levels due to an accurately balanced impeller, it is also one of the most unobtrusive centrifugal kitchen fans available. The front cover design also provides no area for dirt to build up so it stays looking better for longer.

Models

Lo-Carbon Quadra TP (Timer/Pullcord)

Dual speed: continuous running or intermittent to high speed. High speed via pullcord (On/Off) or switch live (with overrun timer).

Model	Stock Ref
TP	439251

Lo-Carbon Quadra HTP (Humidistat/Timer/Pullcord)

Dual speed: continuous running or intermittent to high speed. High speed via integral pullcord (On/Off), integral adjustable humidity sensor or switch live (with overrun timer). When humidity sensor is triggered the flow rate increases proportionally with %RH to 50% of the set Boost speed.

Model	Stock Ref
HTP	439181

Lo-Carbon Quadra TM (Timer/PIR)

Dual speed: continuous running or intermittent to high speed. High speed via integral PIR sensor or switch live (both with overrun timer).

Model	Stock Ref
TM	439253

Accessories

Model	Stock Ref
Flush Mounting Kit	439256
Filter (optional)	439927
Decoration Frame	442551
Wall Kit White	254102
Wall Kit Brown	254100

Dimensions (mm)

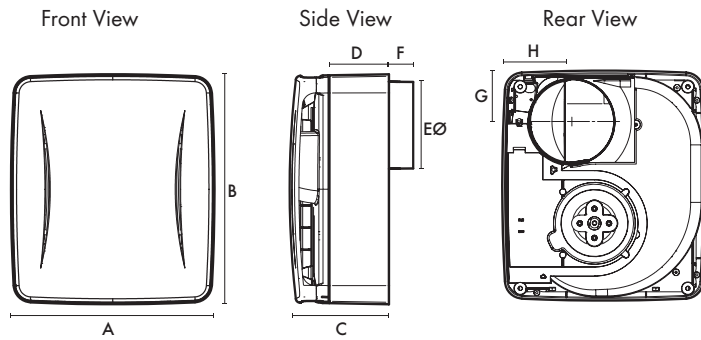

A	B	C	D	EØ	F	G	H
230	260	112	67	98	27	58	79

Performance Guide*

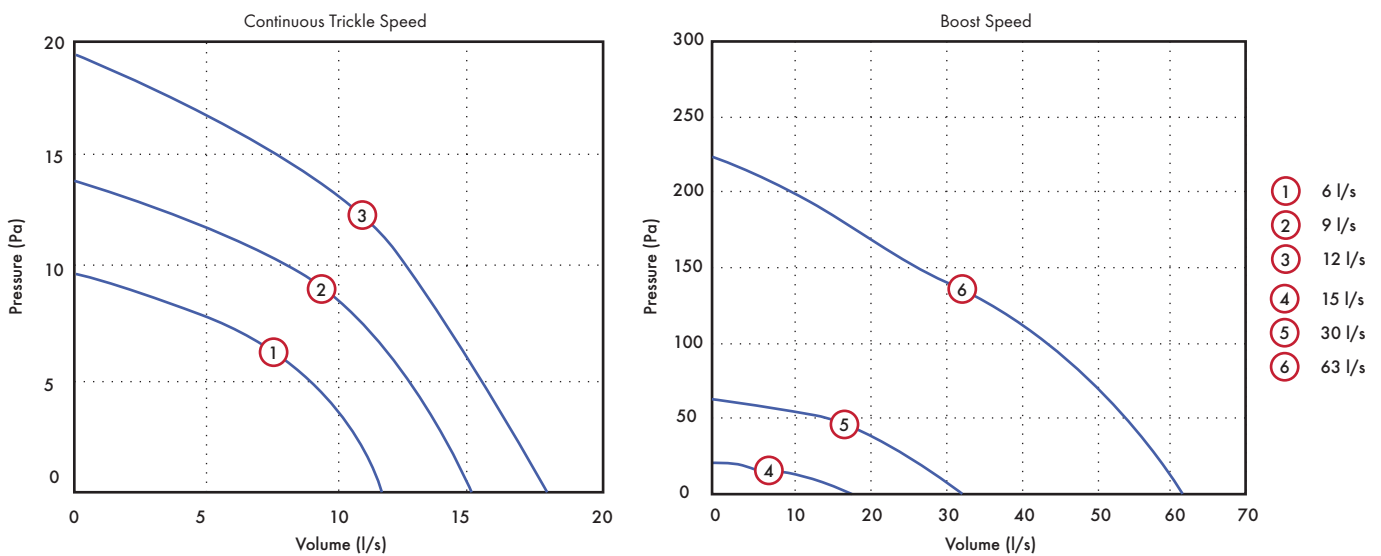

Model	Extract Performance		Power		Sound		SEC Class		
	m ³ /h	l/s	m ³ /h	l/s	High	Low			
Lo-Carbon Quadra TP/ HTP/ TM	227	63	22	6	38	3.8	50	20	D

*FID Performance. Tested in through the wall installation

SAP PCDB Performance

Systems With Rigid Ductwork Installation Only

Unit Configuration	Location	Fan Speed Setting	Flow Rate (l/s)	SFP (W/l/s)
In Room	Kitchen	15 l/s	15.8	0.41
In Room	Wet Room*	9 l/s	14.6	0.61
Through Wall	Kitchen	15 l/s	21.4	0.38
Through Wall	Wet Room*	9 l/s	19.5	0.50

Systems With Flexible Or Mixed Ductwork Installation Only

Unit Configuration	Location	Fan Speed Setting	Flow Rate (l/s)	SFP (W/l/s)
In Room	Kitchen	15 l/s	13.7	0.41
In Room	Wet Room*	9 l/s	12.9	0.63
Through Wall	Kitchen	15 l/s	21.4	0.38
Through Wall	Wet Room*	9 l/s	19.5	0.50

*Not suitable for Zone 1 installation

Lo-Carbon Silhouette 125

- Models Basic/Timer/Humidity & Timer
- Low power consumption - Lower running costs
- Quiet running
- Fully opening and closing non transparent shutters - Improved insulation and privacy
- 1 of 2 speeds selectable at installation
- IPX4 rated
- Ball bearing motors for vertical or horizontal application
- Unique humidity sensor track - Improved response
- 5 year motor warranty
- Suitable for wall, ceiling and panel mounting



Slimline Bathroom Ventilation

With a slim profile of only 18mm, Lo-Carbon Silhouette blends in with the wall surface to provide an unobtrusive installation. Lo-Carbon Silhouette has a FID performance up to 160m³/h. It can be ceiling/panel mounted and connected to an appropriate duct run to the outside.

Models

Lo-Carbon Silhouette 125B

125mm bathroom/toilet fan with indicator light and back draught shutter.

Model **125B** Stock Ref **446483**

Lo-Carbon Silhouette 125T (Timer)

125mm bathroom/toilet fan with integral adjustable electronic overrun timer (5-30 minutes), indicator light which operates on manual override only, and back draught shutter.

Model **125T** Stock Ref **446484**

Lo-Carbon Silhouette 125HT (Humidistat/Timer)

125mm bathroom/toilet fan with integral adjustable auto humidity sensor from 60-90% RH and overrun timer, indicator light which operates on manual override only, and back draught shutter. Datalogger as standard on all Lo-Carbon humidity controlled Silhouette fans.

Model **125HT** Stock Ref **446485**

Accessories

Model **Wall Kit White** Stock Ref **455226**

Dimensions (mm)

Panel

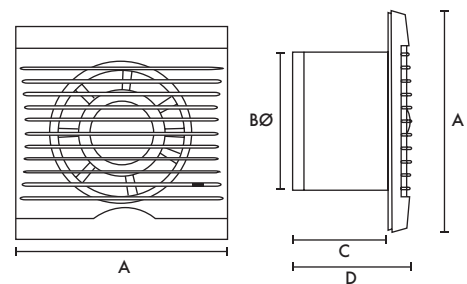

A	BØ	C	D
187	125	131	149

Performance Guide

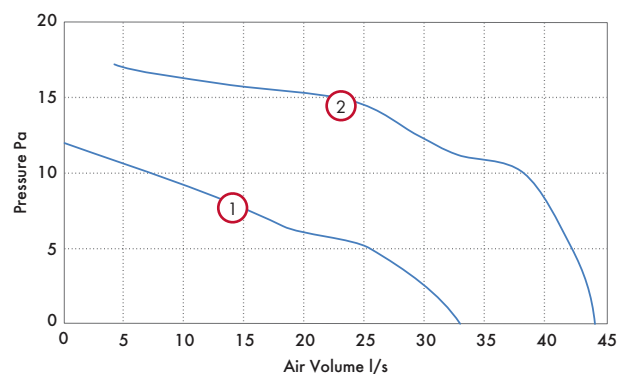

Model	Curve Ref	Extract Performance			Sound dB(A) @ 3m	SFP (W/l/s) @ 0Pa
		m ³ /h	l/s	Watts		
Lo-Carbon Silhouette	Low (1)	120	33	4.5	33	0.14
125B/T/HT	High (2)	160	44	8	37	0.18

Lo-Carbon VA150

- Reduces the home's carbon footprint
- Long life Lo-Carbon motor lasts up to 5 times longer than conventional motors
- Up to 60% energy saving
- Meets current Building Regulations Approved Document F & L when installed
- IP44 rated
- Low sound levels
- 5 year Motor Warranty
- Suitable for wall, ceiling, window and panel mounting
- Fitted with a motorised shutter
- 1 of 2 speeds selectable at installation



Long Life Ventilation

Vent-Axia Lo-Carbon VA150 fans feature Lo-Carbon long life DC energy saving motors that last up to 5 times longer than conventional motors, whilst delivering up to 60% energy savings. The extended life of Lo-Carbon fans is due to the use of a new generation of high quality electronically controlled ball-bearing motors especially developed for this range. The motors are perfectly designed for the wet conditions of utility rooms and kitchens, extracting stale, moisture-laden air quietly and efficiently.

Shutters

The Vent-Axia Lo-Carbon VA150 range is fitted with a motorised shutter mechanism that uses no extra power in operation or off.

Installation

The Lo-Carbon VA150 range is suitable for installation in panels, walls or windows using the kits available. Lo-Carbon fans are quick and simple to fit using reversible grommets and easy-wire terminals, and are suitable for wall or ceiling mounting at any angle.

150mm telescopic wall kits are available with a white or brown outside grille. The kit is supplied with a telescopic wall sleeve to fit walls 225-360mm thick. Hole diameter 152mm.

Window fitting kits are available for use with all Lo-Carbon 150mm models through single or double glazed windows up to 40mm thick. Hole diameter 152mm.

Models

Lo-Carbon VA150P (Shutter/Pullcord)

Ultra long life DC energy saving motor. Fitted with a motorised shutter. Controlled via pullcord On/Off switch.

Model **VA150P** Stock Ref **459123**

Lo-Carbon VA150T (Shutter/Timer)

Ultra long life DC energy saving motor. Fitted with a motorised shutter.

Controlled via integral power supply with electronic adjustable overrun timer (5-30 minutes).

Model **VA150T** Stock Ref **459124**

Lo-Carbon VA150HP (Shutter/Humidistat)

Ultra long life DC energy saving motor. Fitted with a motorised shutter. Controlled via integral power supply with pullcord override switch and adjustable humidity sensor (60-95% RH).

Model **VA150HP** Stock Ref **459125**

Accessories

Model **Wall Kit White** Stock Ref **140902**
 Model **Wall Kit Brown** Stock Ref **140903**
 Model **Window Kit** Stock Ref **140901**

Dimensions (mm)

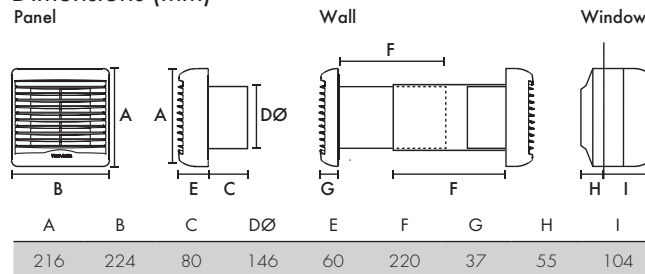

Weight 1.2kg

Performance Guide

Model	Setting	Extract Performance		Sound	Watts	SFP
		m³/h	l/s	dB(A) @ 3m		(W/l/s) @ 0Pa
Lo-Carbon VA150P/T/HP	Utility	160	46	33	7.5	0.16
	Kitchen	230	64	36	11.5	0.18

Lo-Carbon Silhouette 150

- Stylish ultra low profile grille
- Downstream airflow guide vanes for improved pressure development
- Ball bearing motors for vertical or horizontal application
- Wall kit design meets Building Regulations Approved Document F requirements
- 5 year Motor Warranty
- 1 of 2 speeds selectable at installation
- IPX4 rated
- Low Specific Fan Power
- Suitable for wall, ceiling and panel mounting



Slimline Lo-Carbon Kitchen Ventilation

The Lo-Carbon Silhouette 150 range is designed for modern living. With a profile of only 19mm on the kitchen models, Lo-Carbon Silhouette blends in with the wall surface to provide an unobtrusive installation.

Mounted in the centre of the fan, beneath the ultra slim profile grille, are the electronics, incorporating a humidistat (HT model) for detecting a change in internal humidity or an overrun timer option that is adjustable between 5 and 30 minutes. FID performance of 65l/s, double insulated. Power consumption only 9 Watts.

Models

Lo-Carbon Silhouette 150B

150mm kitchen fan with indicator light and back draught shutter.

Model **150B** Stock Ref **441628**

Lo-Carbon Silhouette 150T (Timer)

150mm kitchen fan with integral adjustable electronic overrun timer (5-30 minutes), indicator light which operates on manual override only and spring back draught shutter.

Model **150T** Stock Ref **441629**

Lo-Carbon Silhouette 150HT (Humidistat/Timer)

150mm with integral adjustable auto humidity sensor from 60-90% RH and overrun timer, indicator light which operates on manual override only and back draught shutter. Datalogger as standard on all Lo-Carbon humidity controlled Silhouette fans.

Model **150HT** Stock Ref **441630**

Accessories

Model **Wall Kit White** Stock Ref **140902**
 Model **Wall Kit Brown** Stock Ref **140903**

Dimensions (mm)

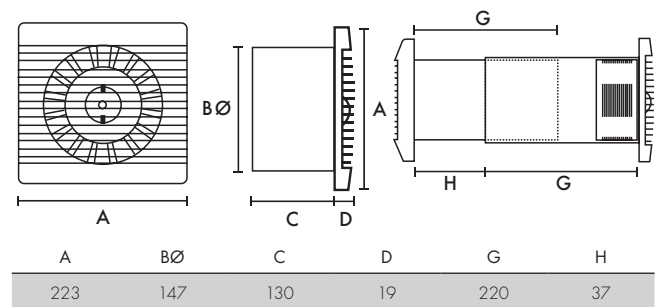

Weight 1.75kg

Performance Guide

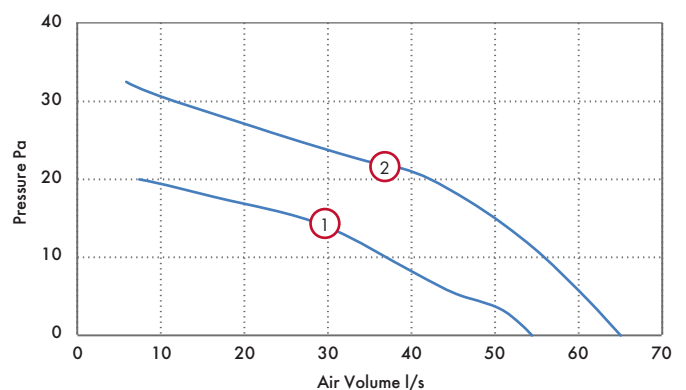

Model	Setting	Curve Ref	Extract Performance			Sound	SFP
			m ³ /h	l/s	Watts	dB(A) @ 3m	(W/l/s) @ 0Pa
150B/T/HT	Utility Setting	1	200	55	6	35	0.11
	Kitchen Setting	2	234	65	9	43	0.14

Fixing hole diameter 152mmØ (when wall kit used)

Vent-Axia

VENTILATION EXCELLENCE

Smart, Stylish, Silent Bathroom Fans



PUREAIR SENSE

Bathroom Fan with Odour Sense Technology



SVARA

Stylish and Versatile Bathroom Fan



SILENT FAN

Silently Improving Indoor Air Quality

Please visit your local wholesaler for more information

Residential Fans



The UK's most comprehensive range of traditional fans for toilets, bathrooms, utility rooms and kitchens.

IPX5 Silent Fan

Now even more discrete than before at only 12dB(A)! The Vent-Axia Silent Fan, the quietest bathroom extract fan on the market.

The Silent Fan Range from Vent-Axia not only delivers stylish and silent ventilation without compromise on performance, but now comes with even more features and more model options providing flexibility when choosing the right fan. Need to hear it to believe it? Email demo@vent-axia.com to arrange a demonstration and hear for yourself just how quiet it is!

Vent-Axia[®]



	VA100/SELV 12 Axial Bathroom/Toilet Fan	C:3-C:4
	Silhouette 100/SELV Axial Bathroom/Toilet Fan	C:5-C:6
	Silent Fan Axial Bathroom/Toilet Fan	C:7-C:8
	Silhouette 125 Axial Bathroom/Toilet Fan	C:9-C:10
	LED LuminAir Fan & Light Combination Unit	C:11-C:12
	LED LuminAir Fan & Light Ventilation Kit	C:13-C:14
	LED LuminAir Turbo Fan & Light Ventilation Kit	C:15-C:16
	Solo Plus Centrifugal Bathroom/Toilet Fan	C:17-C:18
	Solo Pro/SELV Centrifugal Bathroom/Toilet Fan	C:19-C:20
	VA140/150 Axial Kitchen Fan	C:21
	VA150 Window Mount Axial Kitchen Fan	C:22
	Silhouette 150 Axial Kitchen Fan	C:23-C:24
	Centrif Duo Centrifugal Kitchen & Utility Room Fan	C:25-C:26
	Centrif Duo Plus Centrifugal Kitchen & Utility Room Fan	C:27-C:28
	Freshvent Natural Vent	C:29-C:30
	Basics Range Basic, Simple, Solutions	C:31-C:32
	Eclipse Bathroom & Kitchen Axial Fan	C:33-C:34

VA100/SELV

- Indication light
- Panel, ceiling, window or wall mounting
- Available with electric shutter
- Sensors and auto mode controllers save energy by switching the ventilation units on only when needed and when the room is occupied
- Adjustable overrun timer option available (5-30 minutes)
- Meets current Building Regulations Approved Document F
- IPX4 rated - IPX7 rated (SELV)
- SELV Transformer to BS EN 60 742



Bathroom & Toilet Ventilation

The VA100 range from Vent-Axia is designed for domestic bathrooms and toilets. Available as window, wall or panel mounted and with options of shutter, timer or humidity controlled versions.

Designed in a clean white finish and suitable for ambient temperatures up to +40°C the unit is fitted with Standard Thermal Overload Protection (S.T.O.P.).

Safety Extra Low Voltage Fans (SELV)

Designed for areas where a fan has to be fitted over or within Zone 1 in a room containing a fixed bath or shower according to IEE wiring regulations (BS 7671), SELV models can be safely installed within the spray area. SELV models are rated IPX7. Control is by mains safety isolating transformer unit with SELV output, which is sited away from any source of spray and out of reach of a person using a fixed bath or shower.

Models

VA100LP (Pullcord)

Bathroom extract fan pullcord and indication light.

Model	Stock Ref
LP	251110

VA100 SELV

IPX7 rated fan with indication light, complete with remote wall mounted transformer.

Model	Stock Ref
SVL 12 (SELV)	258110

VA100LT (Timer)

Bathroom and toilet fan with adjustable electronic overrun timer and indication light which operates on the override only.

Model	Stock Ref
LT	251210

VA100 SELV (Shutter)

IPX7 rated fan with thermoelectric shutter and indication light, complete with remote wall mounted transformer.

Model	Stock Ref
SVX 12 (SELV)	258310

VA100XP/SELV XP (Shutter/Pullcord)

Bathroom fan with thermoelectric shutter, pullcord and indication light. SELV model IPX7 rated and complete with wall mounted transformer.

Model	Stock Ref
XP	251310
SVXP 12 (SELV)	258310BD025

VA100XT/SELV XT (Timer/Shutter)

Bathroom fan with integral adjustable overrun timer, thermoelectric shutter and indication light which operates on override only. SELV model IPX7 rated and complete with wall mounted transformer.

Model	Stock Ref
XT	251410
SVXT 12 (SELV)	258410

VA100LHP/SELV LHP (Humidity)

Bathroom fan with integral humidity sensor, pullcord override, and indication light which operates on manual override only. SELV model IPX7 rated and complete with wall mounted transformer.

Model	Stock Ref
LHP	251610
SVLHP 12 (SELV)	258112

VA100XHP/SELV XHP (Shutter/Humidity)

Bathroom fan with integral humidity sensor, thermoelectric shutter, pullcord override, and indication light which operates on manual override only. SELV model IPX7 rated and complete with wall mounted transformer.

Model	Stock Ref
XHP	251710
SVXHP 12 (SELV)	258312

VA100XHT/SELV XHT (Shutter/Humidity/Timer)

Bathroom fan with integral humidity sensor and adjustable overrun timer, thermoelectric shutter and indication light which operates on manual override only. SELV model IPX7 rated and complete with wall mounted transformer.

Model	Stock Ref
XHT	251510
SVXHT	258512

Accessories

Model	Stock Ref
Window Kit	254101
Wall Kit White	254102
Wall Kit Brown	254100
Anti-Tamper Window Kit	443234

Dimensions (mm)

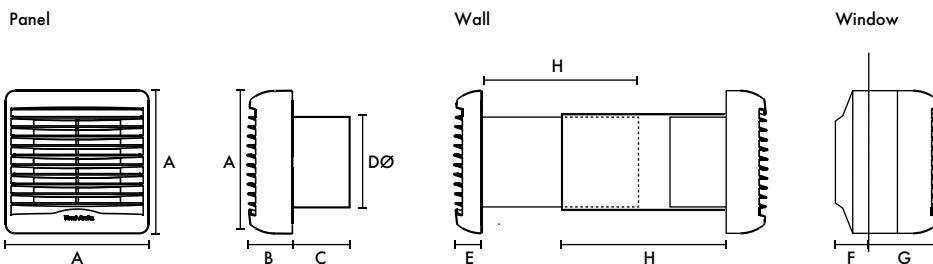

A	B	C	DØ	E	F	G	H
146	47	53	98	31	31	74	200

Weight 0.55kg

Fixing hole diameter 105mmØ (Panel & Window), 117mmØ (Wall). Transformer (WxHxD) 86 x 65 x 147mm

Performance Guide - Panel Models

Model	Extract performance			
	m³/h	l/s	Watts	Sound dB(A) @ 3m
VA100LP	107	30	13	36
VA100LT	107	30	15	36
VA100XP	107	30	15	36
VA100XT	107	30	18	36
VA100LHP	107	30	16	36
VA100XHP	107	30	18	36
VA100XHT	107	30	18	36
VA100SVL	83	23	16	36
VA100SVX	83	23	18	36
VA100SVXT/XHP/XHT/XP	83	23	20	36
VA100SVLHP	83	23	18	36

Silhouette 100/SELV

- 17mm stylish ultra low profile grille
- Downstream airflow guide vanes for improved pressure development
- Designed for vertical or horizontal application
- Indication light (except B model)
- Fan IPX4 rated - IPX7 rated (SELV)
- Suitable for wall, ceiling, panel and window mounting
- Meets current Building Regulations Approved Document F
- SELV transformer to BS EN 60742
- Improved humidistat function



Slimline Bathroom Ventilation

With a slim profile of only 17mm, Silhouette blends in with the wall surface to provide an unobtrusive installation. Silhouette has a FID performance of 21 l/s. Silhouette can be ceiling/panel mounted and connected to an appropriate duct run to the outside.



Safety Extra Low Voltage (SELV) Fans

Safety Extra Low Voltage (SELV) is designed for areas where a fan has to be fitted within zone 1 in a room containing a fixed bath or shower according to IEE wiring regulations. The Silhouette SELV model can be safely installed within the spray area. SELV models are rated IPX7, control is by a mains safety isolating transformer with 12V AC SELV output, which is sited away from any source of spray and out of reach of a person using a fixed bath or shower.

Models

Silhouette 100B/SELV B

Single speed 100mm bathroom/toilet fan with back draught shutter. Indication light on SELV model only.

Model	Stock Ref
B	454055
SVB (SELV)	439974

Silhouette 100T/SELV T (Timer)

Single speed 100mm bathroom/toilet fan with integral adjustable electronic overrun timer (5-30 minutes), indication light and back draught shutter.

Model	Stock Ref
T	454056
ST (SELV)	439975

Silhouette 100HT (Humidity/Timer)

Single speed 100mm bathroom/toilet fan with integral adjustable auto humidity sensor from 60-90% RH, fixed 15 minute overrun timer option via jump switch, indication light and back draught shutter.

Model	Stock Ref
HT	454057

Silhouette 100 SELV SVH (Humidity)

Single speed 100mm bathroom/toilet fan with integral adjustable auto humidity sensor from 60-90% RH, indication light and back draught shutter.

Model	Stock Ref
SVH (SELV)	439976

Silhouette 100TM (PIR/Timer)

Single speed 100mm bathroom/toilet fan. Integral PIR operated model, (presence detector) with adjustable electronic overrun timer (5-30 minutes) indication light and back draught shutter.

Model	Stock Ref
TM	454058

Accessories

Model	Stock Ref
Wall Kit White	254102
Wall Kit Brown	254100
Window kit	442947

Dimensions (mm)

Panel

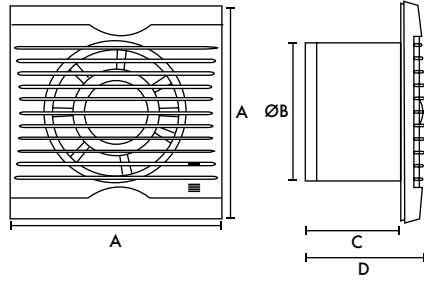

Wall Kit

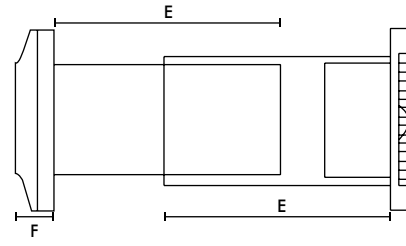

A	BØ	C	D	E	F
160	99	80	97	200	32

Transformer (W X H X D) 86 x 65 x 147

Weight 0.6kg

Fixing hole diameter 105mmØ (Panel & Window), 117mmØ (Wall)

Performance Guide

Model	Extract Performance - FID			Sound dB(A)
	m ³ /h	l/s	Watts	@ 3m
Silhouette 100B/T/H/TM	75	21	16	30
Silhouette 100SVB/SVT/SVH	75	21	15	30

Silent Fan

- Stylish open front models
- From only 12dB(A)
- IPX5 - Zone 1 rated
- Meets current Building Regulations Approved Document F and L
- 2 speeds to choose from at installation
- Back draught shutters included
- High efficiency motor
- 2 year warranty
- Suitable for wall, ceiling, window and panel mounting

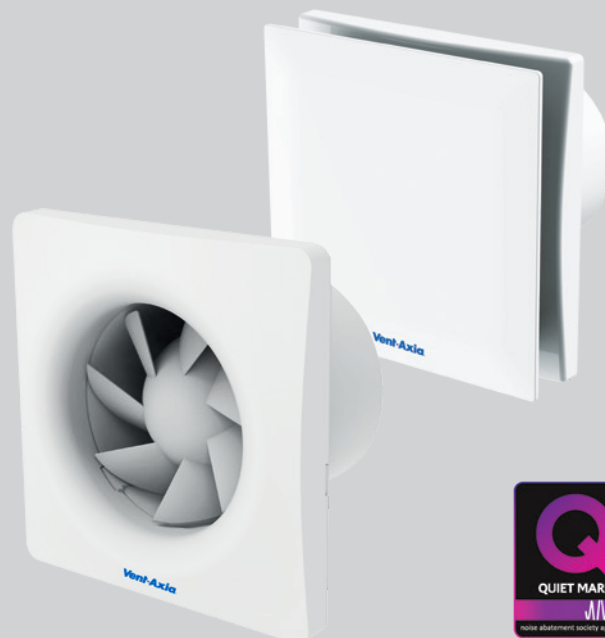

Silent Fan Axial Bathroom/Toilet Fan

The Silent Fan Range from Vent-Axia not only delivers stylish and silent ventilation without compromise on performance, but now comes with even more features and more model options providing flexibility when choosing the right fan.

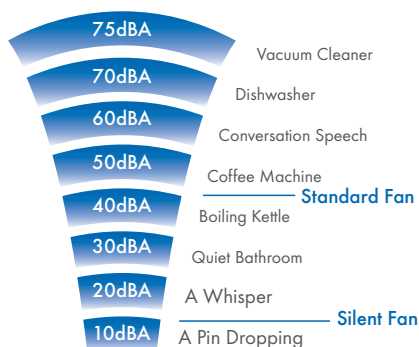

Models

Zone 1 Fixed Speed, Intermittent

Remote or light switch operation. 2 speed options selectable at install. Intermittent operation.

Model	Stock Ref
VASF100B (closed grille)	446658B
VASF100BO (open grille)	495697

Zone 1 Fixed Speed, Intermittent, Timer

Overrun timer adjustable 5-30 min. 2 speed options selectable at install. Intermittent operation.

Model	Stock Ref
VASF100T (closed grille)	446659B
VASF100TO (open grille)	495698

Zone 1 Fixed Speed, Intermittent, Humidity Timer

Humidity controlled with fixed 15 min timer overrun. 2 speed options selectable at install. Intermittent operation.

Model	Stock Ref
VASF100HT (closed grille)	477436B
VASF100HTO (open grille)	495699

PIR Model

Zone 1 Fixed Speed, Intermittent, PIR

Motion detection, presence infrared motion control with overrun timer adjustable 5-30min. Single speed.

Model	Stock Ref
VASF100PIRO (open grille)	495705

Accessories

Model	Stock Ref
Window Kit	442947
Wall Kit White	254102
Wall Kit Brown	254100
Internal Fit Wall Kit White + Backdraught Shutter	474779

Dimensions (mm)

Closed Grille

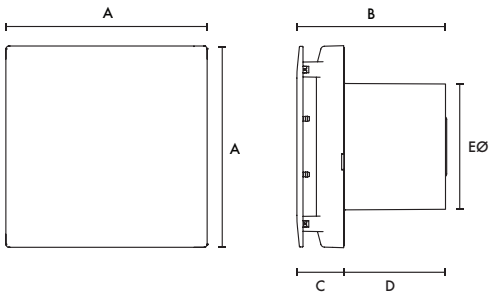

Open Grille

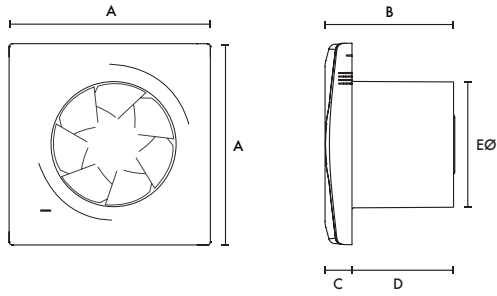

Grille	A	B	C	D	EØ
Closed	160	117	37	80	99
Open	160	117	22	80	99

Weight 0.7kg

Performance Guide

Closed Grille

Open Grille

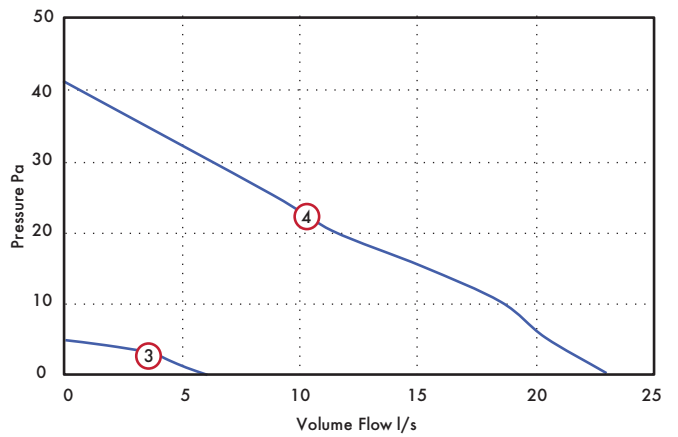
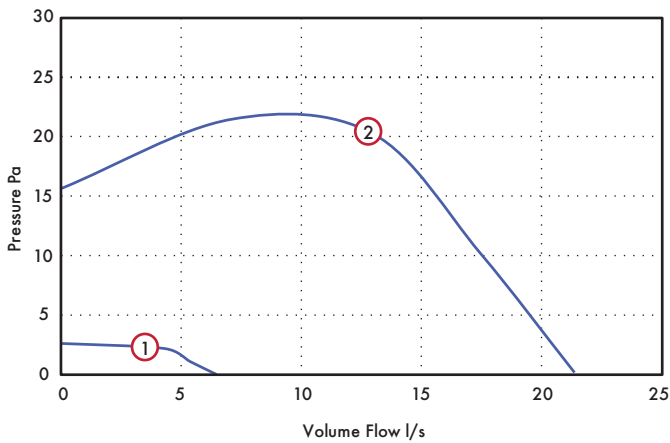

	Model	Speed	l/s	Watts	Warranty (years)
2 Speed	VASF100B/T/	① Low	6	2.7	2
	HT	② High	21	4.8	

	Model	Speed	l/s	Watts	Warranty (years)
2 Speed	VASF100BO/	③ Low	6	2.7	2
	TO/HTO/	④ High	23	4.8	

12dB(A) - Sound dB(A) @3m at low speed

12dB(A) - Sound dB(A) @3m at low speed

Silhouette 125

- 18mm stylish ultra low profile grille
- Downstream airflow guide vanes for improved pressure development
- Designed for vertical or horizontal application
- Modern aesthetic with indication light
- IPX4 rated
- Suitable for wall, ceiling and panel mounting



Slimline Bathroom Ventilation

With a slim profile of only 18mm, Silhouette blends in with the wall surface to provide an unobtrusive installation. Silhouette has a FID performance of 160m³/h. Silhouette can be wall, ceiling or panel mounted and connected to an appropriate duct run to the outside.



Accessories



Model
Wall Kit

Stock Ref
455226

Models

Silhouette 125B

Single speed 125mm bathroom/toilet fan with indication light and back draught shutter.

Model	Stock Ref
B	445161

Silhouette 125T (Timer)

Single speed 125mm bathroom/toilet fan with integral adjustable electronic overrun timer (5-30 minutes), indication light and back draught shutter.

Model	Stock Ref
T	445162

Silhouette 125H (Humidistat)

Single speed 125mm bathroom/toilet fan with integral adjustable auto humidity sensor from 60-90% RH, indication light and back draught shutter.

Model	Stock Ref
H	445163

Dimensions (mm)

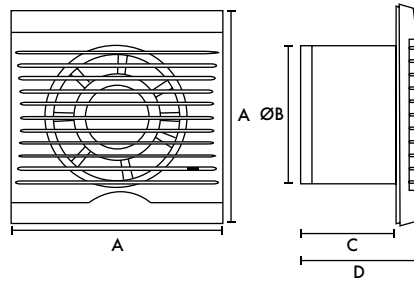

A	BØ	C	D
187	125	131	149

Performance Guide

Model	Extract Performance - FID			Sound dB(A)
	m ³ /h	l/s	Watts	@ 3m
Silhouette 125B/T/H	160	45	20	40

LED LuminAir Fan & Light Combination Unit

- The original fan and light combination
- IPX7 rated
- Suitable for shower enclosures and wet areas - can be used within reach of a person using a bath or shower
- Safety extra low voltage (SELV)
- Easy installation
- White and Chrome bezels available
- LED Lamp



Safety Extra Low Voltage

The revolutionary Vent-Axia LuminAir Safety Extra Low Voltage fan and light in a single ceiling mounted fitting.

The IPX7 unit is installed directly over a shower in complete safety. Vent-Axia LuminAir extracts moisture and humidity at source, preventing damaging condensation from spreading. At the same time it bathes the shower enclosure in a rich soft light - bringing any dark shower to life. Ideal for all types of bathroom and shower applications, and is particularly suitable for bedsit and en-suite shower installations.

Designed for mounting in a wide variety of ceiling thicknesses. The safety isolating transformer to BS EN 60742 is mounted in a purpose made enclosure that can be wall mounted or sited in the loft, and is designed to accept mini trunking (LuminAir L transformer - IP20 - loft mounted).

LuminAir has a LED MR16 3W DC 12V lamp to give a pool of soft warm light. The lamp has a long life and is simple to change.

Separate LED Driver also included.

Models

LuminAir L (Switch Live)

Provides simultaneous fan and light operation from the bathroom light switch.

Model	Stock Ref
L	188110

LuminAir T (Timer)

Switches the fan On with the light. When the light is switched Off, the fan continues to run for an adjustable set period to meet the Building Regulations for internal bathrooms.

Model	Stock Ref
T	188210

LuminAir H (Humidistat)

Combines a light activated by the bathroom light switch and an Ecotronic Humidity Sensor which will switch the fan On whenever the humidity level warrants.

Model	Stock Ref
H	188610

Supply to the LuminAir LED Driver Input: AC100-240V, 50/60Hz, Output: DC12V 500mA, LED Power - 3-5W.

Output to LuminAir 12V SELV/1/50Hz. Safety isolating transformers conform to BS EN 60742.

Accessories

Model	Stock Ref
Optional Bezel Chrome	452044

LuminAir Vent Light Safety Extra Low Voltage Duct Air Inlet

LuminAir Vent Light is for upgrading existing extract systems or to provide multiple extract points to a central fan. The Vent Light consists of a LuminAir Safety Extra Low Voltage (SELV) light with white ceiling bezel and 90° bend suitable for use with remote extract fan using 100mm duct. On/Off operation is via the bathroom light switch. Gold and chrome bezels are available as accessories.

Model	Stock Ref
White	453395

Dimensions (mm)

Vent Light

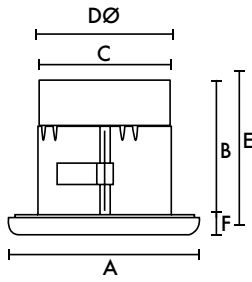

Humidity Sensor

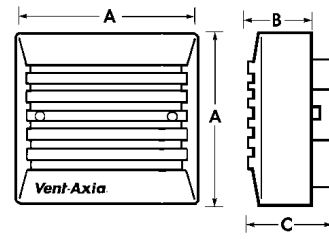

Model	A	B	C	DØ	E	F	G
LuminAir	150	140	98	103	150	10	180
Humidity Sensor	87	33	47				

Fixing hole diameter 110mm

Performance

Model	Extract performance - FID		Max Watts		Sound dB(A)	Amps
	m ³ /h	l/s	Fan	Lamp	@ 3m	@ 240V
LuminAir L	110	31	20	3	35	0.2
LuminAir T	110	31	22	3	35	0.2
LuminAir H	110	31	24	3	35	0.2

LED LuminAir Fan & Light Ventilation Kit

- Unique fan and light combination
- IPX7 rated inlet assembly
- Suitable for shower enclosures and wet areas - can be used within reach of a person using a bath or shower
- Safety extra low voltage (SELV) fan and lamp
- Easy installation
- White and Chrome bezels available
- LED Lamp



SELV Fan & Light Combination

LuminAir is also available in the form of a ventilation kit which, in addition to the fan and light combination, comes with a 90° bend, 3M of flexible ducting, wall grille and cable ties. The IPX7 unit is installed directly over a shower in complete safety.

Vent-Axia LuminAir extracts moisture and humidity at source, preventing damaging condensation from spreading. At the same time it bathes the shower enclosure in a rich soft light - bringing any dark shower to life. Ideal for all types of bathroom and shower applications, and is particularly suitable for bedsit and en-suite shower installations. LuminAir has a LED MR16 3W DC 12V lamp, to give a pool of soft warm light. The lamp has a long life and is simple to change.

Separate LED Driver also supplied, Input: AC100-240V, 50/60Hz, Output: DC12V 500mA, LED Power - 3-5W.

Models

LuminAir L, T or H SELV fan and light, choice of bezel, 90° bend, 3m of flex-duct, wall grille and cable ties.

LuminAir Shower Ventilation Kit L (Switch Live)

Provides simultaneous fan and light operation from the bathroom light switch.

Stock Ref
453410 (White)

LuminAir Shower Ventilation Kit T (Timer)

Switches the fan On with the light. When the light is switched Off, the fan continues to run for an adjustable set period.

Stock Ref
453413 (White)

LuminAir Shower Ventilation Kit H (Humidistat)

Combines a light activated by the bathroom light switch and an Ecotronic Humidistat Sensor which will switch the fan On whenever the humidity level warrants.

Stock Ref
453416 (White)

Accessories

Optional Bezels
Stock Ref
452044 (Chrome)

Installation Example

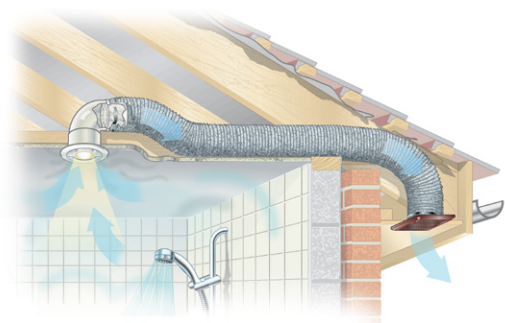

Dimensions (mm)

Vent Light

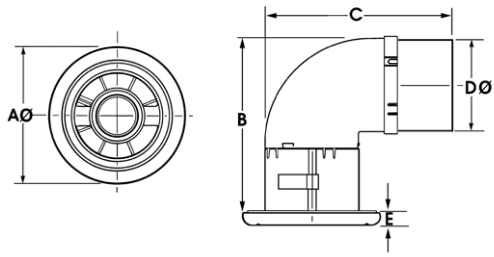

Humidity Sensor

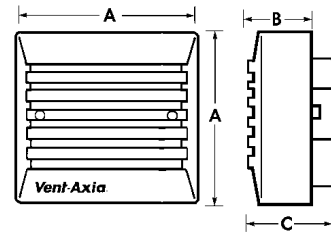

Model	AØ	B	C	DØ	E
Vent Light	150	180	139	98	10
Humidity Sensor	87	33	47		

Fixing hole diameter 110mm

Performance

Model	Extract Performance - FID		Watts		Sound dB(A) @ 3m	Amps @ 240V
	m ³ /h	l/s	Fan	Lamp		
LuminAir Ventilation Kit L/T/H	110	31	20	3	35	0.2

LED LuminAir Turbo Fan & Light Ventilation Kit

- Unique fan and light combination
- IPX7 rated inlet assembly
- Suitable for shower enclosures and wet areas - can be used within reach of a person using a bath or shower
- Safety extra low voltage (SELV) lamp
- Easy installation
- White and Chrome bezels available
- LED Driver



High Performance Fan & Light Combination

LuminAir is also available in the form of a ventilation kit. The IPX7 unit is installed directly over a shower in complete safety.

Vent-Axia LuminAir extracts moisture and humidity at source, preventing damaging condensation from spreading. At the same time it bathes the shower enclosure in a rich soft light - bringing any dark shower to life. Ideal for all types of bathroom and shower applications, and is particularly suitable for bedsit and en-suite shower installations. LuminAir has a LED MR16 3W DC 12V Lamp, to give a pool of soft warm light. The lamp has a long life and is simple to change. Comes with a LED Driver, Input: AC100-240V, 50/60Hz, Output: DC12V 500mA, LED Power - 3-5W

Models

For applications where a more powerful system is required, the kit comprises a luminair turbo L or T mains fan and SELV light, choice of bezel, 90° bend, 6 metres of flexible duct, quick fix wall grille and four cable ties. Meets Building Regulations approved Document F performance assuming ductwork provided is fully extended and one 90° bend.

LuminAir Turbo SKL (Switch Live)

Provides simultaneous On and Off operation of the fan and light switch from the bathroom light switch.

Model	Stock Ref
SKL White	453419

LuminAir Turbo SKT (Timer)

Switches the fan On with the light switch. When the light is switched Off, the fan continues to run for an adjustable fixed period to meet the Building Regulations for internal bathrooms.

Model	Stock Ref
SKT White	453422

Accessories

Model	Stock Ref
Optional Bezel Chrome	452044

Installation Example

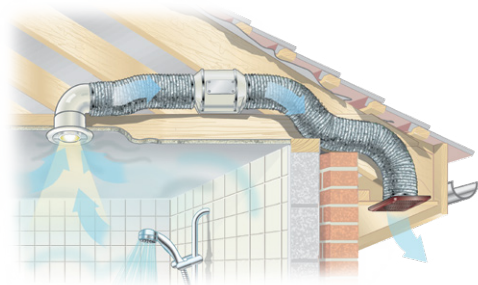

Dimensions (mm)

Vent Light and Bend

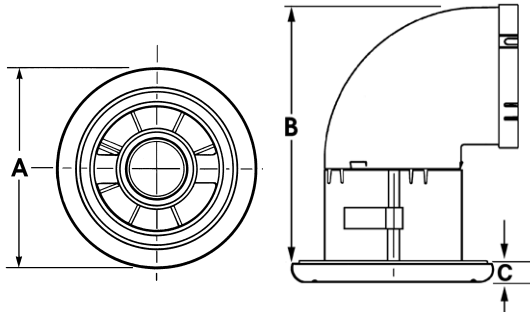

Turbo Fan

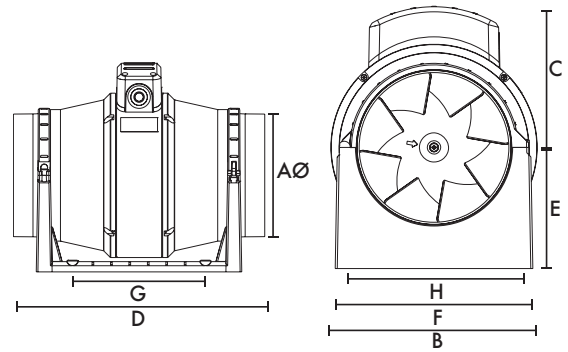

Model	AØ	B	C	D	E	F	G	H
Vent Light	150	180	10					
Turbo Fan	97	178	124	298	96	168	120	153.5

Ceiling Fixing hole diameter 110mm

Performance

Model	Extract Performance - FID		Watts		Sound dB(A)	Amps
	m ³ /h	l/s	Fan	Lamp	@ 3m	@ 240V
SKL/SKT	160	52	8	3	23	0.3

Solo Plus

- Filterless as standard - innovative impeller design means no need for a filter
- Meets current Building Regulations Approved Documents F & L requirements for domestic bathrooms and toilets
- IPX4 rated
- Flush or surface mountable
- Adjustable rear or side exit spigot
- Extremely low sound levels
- Suitable for wall, ceiling and panel mounting



Bathroom & Toilet Ventilation

The Solo Plus range from Vent-Axia has been specially designed for through the wall and ducted applications, suitable for internal bathrooms, toilets and other small rooms. Finished in white, the Solo Plus can be flush or surface mounted, with a 100mm circular spigot for rear entry or connecting to a vertical ducting system. The spigot can also be adjusted for sideways exhaust enabling recessed ceiling installations within limited ceiling voids. The powerful centrifugal impeller allows for installations with longer duct runs using 100mm ducting, whilst still achieving 15 l/s as required by Document F of the current Building Regulations.

Continuous running products, such as the Solo Plus installed in all wet areas of a dwelling are classed as a wholehouse ventilation system and therefore, only needs to move the amount of air as laid down in table 1.1b of Document F.

The Solo Plus has a choice of two boost/override motor speeds set at installation, medium (17l/s) or high (22l/s), with an optional constant trickle speed (9l/s), also selectable at installation except in the P model. Depending on the model, the fan will switch from trickle (if selected) to boost (medium or high) via the pullcord/light switch/humidity sensor/PIR.

All models can be wall, panel or ceiling mounted and can be connected to either circular, rectangular or Vent-Axia's flat ducting. Enclosure of the electrical components is manufactured from flame retardant grade material.

Supply voltage 220-240V/1/50Hz.

Models

Solo Plus P (Pullcord)

Flush or surface mountable. Control by pullcord single speed; 1 of the 3 speeds selectable at installation.

Model	Stock Ref
P	427477

Solo Plus T (Timer)

Flush or surface mountable. Constant trickle option. 2 Speed. Adjustable timer overrun. Delay on timer option.

Model	Stock Ref
T	427478

Solo Plus HT (Humidistat/Timer)

Flush or surface mountable. Humidity controlled fan with override pullcord. Constant trickle option. Adjustable timer overrun. Delay on timer option. Adjustable humidity sensor.

Model	Stock Ref
HT	427479

Solo Plus TM (Timer/PIR)

Flush or surface mountable. Control by integral PIR detector. Constant trickle option. 2 Speed.

Model	Stock Ref
TM	427480

Accessories

Solo Plus Bezel

Used when flush mounting, reduces the need to make good.

Model	Stock Ref
Bezel	404106

Model	Stock Ref
Wall Kit White	254102
Wall Kit Brown	254100

Filter pack (1 per pack)

The design of the Solo Plus means that it does not need a filter. However, if you are going to install the product in a heavily greasy environment, you may want to protect the product by fitting a filter.

Model	Stock Ref
Filter pack	449265

Dimensions (mm)

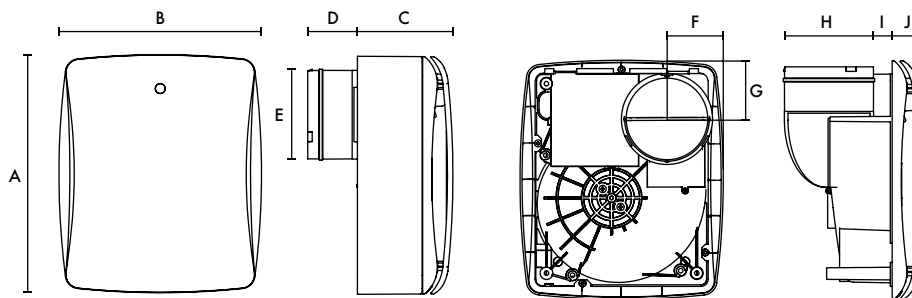

A	B	C	D	EØ	F	G	H	I	J
263	224	106	55	98	62	65	98	21	34

Performance Guide

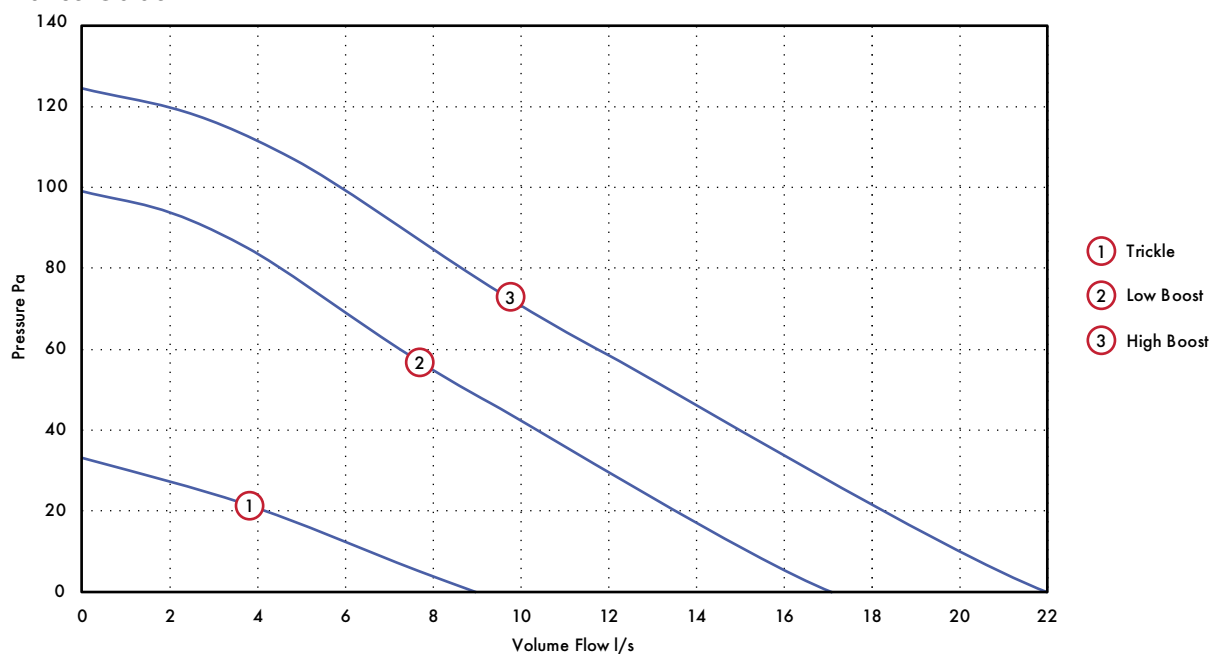

Model	Extract Performance l/s (m ³ /h) - FID			Watts			dB(A) @ 3m		
	Max Boost	Min Boost	Trickle	Max Boost	Min Boost	Trickle	Max Boost	Min Boost	Trickle
Solo Plus P/T/HT/TM	22 (80)	17 (61)	9 (32)	17.1	10.9	6.3	34.5	24	11.5

Tested at 240VAC @ 50Hz

Solo Pro/SELV

- 100mm high performance centrifugal extract fan for internal bathrooms, toilets and other small rooms
- Extract performance 22l/s
- Single speed and overrun timer models
- Suitable for wall, ceiling, panel and window mounting
- SELV models suitable for installation over or within reach of a shower or bath
- Suitable for use with flat ducting
- IPX4 rated - IPX7 rated (SELV)
- Transformer complies with BS EN 60742



High Performance Ventilation

The new Solo Pro is a new and improved version of our trusted Solo model. With improved aesthetics, sound and installation it has been specifically designed for effective ducted ventilation of internal bathrooms, toilets and other small rooms. Finished in White, the new Solo Pro range can be used with 100mm diameter smooth bore duct in straight runs equal to 50m, yet still meets the minimum 15l/s required by the current Building Regulations Document F for ventilation of bathrooms. Solo Pro can also be used with flat ducting for shorter concealed runs.

Models are available for surface or recessed mounting directly into standard 100mm diameter ducting. Suitable for panel, wall and ceiling installations and windows up to 25mm thick. For high rise or coastal applications, install through the wall with a Vent Cowl (Stock Ref 561403).

Safety Extra Low Voltage

SELV models are designed for areas where a fan has to be fitted within zone 1 in a room containing a fixed bath or shower according to IEE wiring regulations. The Solo SELV models can be safely installed within the spray area. The SELV models are rated IPX7, control is by a mains safety isolating transformer with 12V AC SELV output, which is sited away from any source of spray and out of reach of a person using a fixed bath or shower.

The safety isolating transformer, to BS EN 60742, is mounted in a purpose made enclosure. The enclosure can be wall mounted or sited in the loft. The enclosure will accept mini trunking.

Electrical

Rear 20mm conduit entry for recessed wiring and side entry grommet for surface wiring.

Supply voltage to transformer/controller 220-240V/1/50Hz. Output to fan 12V SELV/ 1/50Hz.

To meet IEE Regulations, timer models should be isolated using a 3 pole isolator.

Model	Stock Ref
3 pole isolator	563518

Models

Solo Pro P/SELV SVP (Pullcord)

Control by pullcord or from light/remote switch or sensor. Back draught shutter. SELV model comes with mains transformer with 12V SELV output.

Model	Stock Ref
P	409159
SVP (SELV)	409163

Solo Pro T/SELV T (Timer)

Control by light/remote switch. Overrun timer variable from 5 to 30 minutes. Back draught shutter. SELV model comes with mains transformer with 12V SELV output.

Model	Stock Ref
T	409160
SVT (SELV)	409164

Solo Pro HTP/SELV SVHTP (Humidity/Timer)

Humidity controlled with pullcord override. 17 min overrun timer. Back draught shutter. SELV model comes with mains transformer with 12V SELV output.

Model	Stock Ref
HTP	409161
SVHTP (SELV)	409165

Solo Pro TM (Timer/PIR)

Controlled by separate PIR sensor supplied with fan. Built in overrun timer, variable from 5 to 30 minutes, switches fan Off.

Model	Stock Ref
TM	409162

Accessories

Model	Stock Ref
Wall Kit White	254102
Wall Kit Brown	254100
Window Kit	11461685

Dimensions (mm)

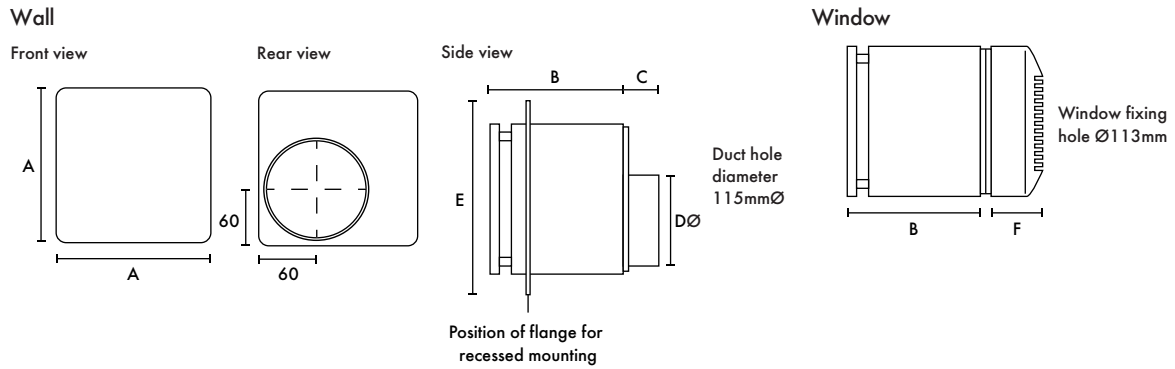

Model	A	B	C	DØ	E	F
Solo Pro/SELV12 P/T/HTP/TM	154	119	25	100	195	57.5

Transformer (W x H x D) 86 x 65 x 147mm

Performance Guide

Model	Extract Performance		Max Watts	dB(A) @ 3m	Amps @ 240V
	m ³ /h	l/s			
Solo Pro SELV12/T/HP	80	22	19	30	0.26
Solo Pro P/T/HTP/TM	80	22	17	30	0.15

VA140/150

- VA140/150 Panel models
- 2 Year Warranty
- Thermo electric shutters to prevent back draughts
- Meets current Building Regulations Approved Document F
- IP44 rated
- Suitable for wall, ceiling, panel and window mounting



Kitchen Ventilation

VA140/150 Panel models are designed to alleviate the everyday problems that condensation and household odours may cause. Effectively extracts odours and moisture laden air from kitchens giving a healthy and fresh environment.

Building Regulations

Specifically sized to meet the current Building Regulation requirements for powered extract ventilation in domestic kitchens. Control facility fitted as standard. The VA140/150 range is fitted with internal louvres conforming to the latest international safety standards.

Please contact our Customer Service Department for exposed site application.

Models

VA140/150KP (Pullcord)

Single speed kitchen extract fan with On/Off pullcord.

Model **Stock Ref**
KP **140120**

VA140/150KT (Timer)

Single speed kitchen extract fan with adjustable overrun timer (3-30 minutes).

Model **Stock Ref**
KT **140220**

VA140/150KHP (Humidistat)

Single speed humidity-controlled kitchen extract fan with full speed pullcord override. Humidity adjustment 62-82%RH.

Model **Stock Ref**
KHP **140320**

VA140/150KHT (Timer/Humidistat)

Humidity controlled kitchen extract fan with adjustable overrun timer (3-30 minutes). Humidity adjustment 62-82% RH.

Model **Stock Ref**
KHT **140420**

VA140/150VS (Variable Speed)

Variable speed kitchen extract with a built in adjustable speed controller, which can reduce the speed to 40% of its maximum performance.

Model **Stock Ref**
VS **458915**

Accessories

Model **Stock Ref**
Wall Kit White **140902**
Wall Kit Brown **140903**
Window Kit **140901**

Dimensions (mm)

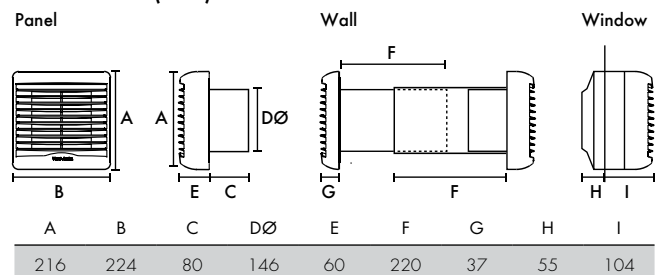

Weight 1.75kg

Fixing hole Ø 152mm (Panel), Ø 160mm (Window), Ø 152mm (Wall)

Performance Guide

Model	Shutter Actuator	Extract Performance FID		Sound	
		m³/h	l/s	Watts	dB(A) @ 3m
VA140/150KP	Pullcord	245	68	18.8	36
VA140/150KT/KHP/KHT	Instant	245	68	18.8	36
VA140/150VS	Pullcord	100 - 245	28 - 68	18.8	36

VA150

- Complete with window kit
- 2 Year Warranty
- Meets current Building Regulations Approved Document F
- Integrated, concealed shutter
- Natural trickle vent facility when unpowered



Kitchen Ventilation

VA150 Window models are designed to alleviate the everyday problems that condensation and household odours may cause. Effectively extracts odours and moisture laden air from kitchens giving a healthy and fresh environment.

Shutter

The louvre shutter on the VA150 is concealed behind the interior grille. Operates automatically when the fan is switched On. Natural trickle vent facility (unpowered) available on all models.

Building Regulations

The VA150 Range is specifically sized to meet the current Building Regulation requirements for powered extract ventilation in domestic kitchens. The VA150 range is fitted with internal and external louvres conforming to the latest international safety standards.

Motor

Maintenance free, sealed for life ball bearings in the purpose made electric motor, economical and quiet running. Double insulated appliance. Supply voltage 220-240V/1/50Hz.

Models

VA150P (Pullcord)

Specifically designed for domestic use in kitchens and utility rooms, the VA150P is a single speed 150mm (6") extract ventilation unit for windows. Fan and shutter operated by integral pullcord. (window kit supplied). IP24 Rated. Colour: white.

Model P **Stock Ref** 152110

VA150A

A single speed 150mm (6") extract fan with instant opening/closing shutter operated by remote switch. Suitable for installation in bathroom or kitchen. (Window kit supplied). IP44 Rated. Colour: white.

Model A **Stock Ref** 153110

Dimensions (mm)

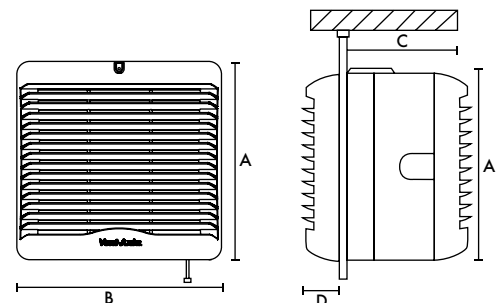

A	B	C	D
216	224	130	55

Weight 2.5kg

Window fixing hole \varnothing 184mm

Performance Guide

Model	Shutter Attenuator	Extract Performance FID			Sound dB(A)
		m ³ /h	l/s	Watts	@ 3m
VA150P/A	Pullcord/Instant	220	60	19	37

Silhouette 150

- Stylish ultra low profile grille
- Downstream airflow guide vanes for improved pressure development
- Modern aesthetics
- Electric back draught shutters
- IPX4 rated
- Suitable for wall, ceiling and panel mounting
- Meets current Building Regulations Approved Document F



Slimline Kitchen Ventilation

The Vent-Axia Silhouette range is designed for modern living. With a profile of only 19mm on the kitchen models, Silhouette blends in with the wall surface to provide an unobtrusive installation.

Mounted in the centre of the fan, beneath the ultra slim profile grille, are the electronics, incorporating a humidistat for detecting a change in internal humidity or an overrun timer option that is adjustable between 5 and 30 minutes.

Models

Slim profile only 19mm. FID performance of 241 m³/h, double insulated.

Silhouette 150X

Single speed 150mm kitchen fan with electric back draught shutter.

Model	Stock Ref
X	454059

Silhouette 150XT

Single speed 150mm kitchen fan with integral adjustable electronic overrun timer (5-30 minutes), indication light and electric back draught shutter.

Model	Stock Ref
XT	454060

Silhouette 150XH

Single speed 150mm with integral adjustable auto humidity sensor from 60-90% RH, indication light and electric back draught shutter. Switch live for override by remote switch/light switch.

Model	Stock Ref
XH	454061

Accessories

Model	Stock Ref
Wall Kit White	140902
Wall Kit Brown	140903

Dimensions (mm)

Panel

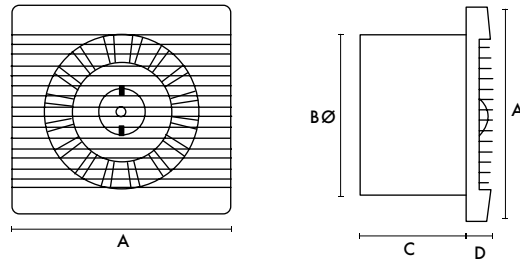

Wall

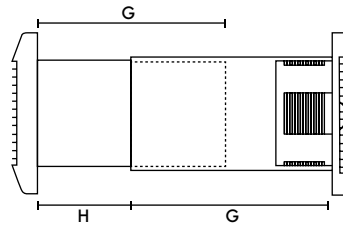

Fixing hole diameter 1.52mmø (when wall kit used)

A	B	C	D	G	H
223	147	111	19	220	37

Weight 1.75kg

Performance

Model	Extract Performance - FID			Sound dB(A)
	m ³ /h	l/s	Watts	@ 3m
Silhouette 150X/XT/XH	241	67	20	43

Centrif Duo

- 100mm circular spigot for speedy installation
- Humidity sensing model for automatic operation
- Suitable for both kitchen and utility rooms
- Includes washable grease filter and removable grille assembly for easy cleaning
- Speed set at installation
- Meets current Building Regulations Approved Document F
- Timer model for internal rooms
- Surface mounted



Kitchen & Utility Ventilation

The Centrif Duo range is a series of 100mm centrifugal extract fans for the domestic environment. The range is designed to provide extraction levels that comply with Building Regulation requirements, with special humidity sensing variants for local authority use.

Motor

The motor features greased-for-life ball bearings which allow the fan to be installed at any angle. Insulation is Class E. Double insulated appliance. Supply voltage 220-240V/1/50Hz.

Fast Installation

The Centrif Duo has a 100mm circular spigot. The Flush mounting kit enables the spigot to be converted to a side outlet. The spigot also encloses a built-in, spring operated back draught shutter. The Centrif Duo Range can be wall mounted using a telescopic wall fitting kit available as an accessory (requires a 115mm diameter hole).

Humidistat Control

Humidistat is selectable for either kitchen or utility speed separate to any other control to reduce nuisance noise. Boost operation by pullcord or switch live.

Models

Centrif Duo P (Pullcord)

Two speed kitchen extract fan with pullcord. Choice of two speeds for boost, set at installation.

Model	Stock Ref
P	256120

Centrif Duo T (Timer)

Two speed kitchen extract fan with adjustable timer between 5-30 minutes. Choice of two speeds for boost, set at installation.

Model	Stock Ref
T	256220

Centrif Duo DP (Two Speed)

Two speed and Off with pullcord or remote switch. Switches between Off, Low and one of the 2 Boost speeds.

Model	Stock Ref
DP	256320

Centrif Duo HTP (Humidity)

Intermittent on 1 of 2 speeds (Utility or Kitchen selectable at installation). Operation by integral humidity sensor or pullcord. Separate speeds selectable for humidistat and pullcord. Optional continuous trickle speed available at installation.

Model	Stock Ref
HTP	256420

Accessories

Flush Mounting Kit

Bezel, clips and 90° duct elbow reduces the need to make good.

Model	Stock Ref
Flush Mounting Kit	439256

Model	Stock Ref
Wall Kit White	254102
Wall Kit Brown	254100
Decoration Frame	442551

Dimensions (mm)

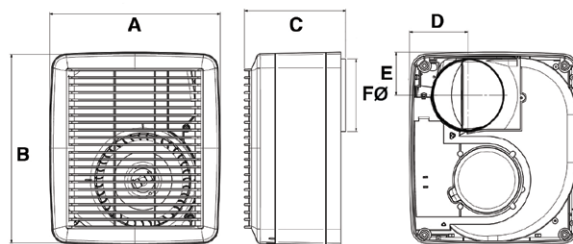

A	B	C	D	E	FØ
231	261	137	79	58	98

Weight 1.75kg

Performance

Model	Performance @ 0 pa						Power (W)			Sound dB(A) @ 3m			SEC Class
	High speed		Med speed		Low speed		Kitchen	Utility	Trickle	Kitchen	Utility	Trickle	
	m ³ /h	l/s	m ³ /h	l/s	m ³ /h	l/s							
Centrif Duo P/T	220	61	130	36	-	-	60	41	N/A	51.8	38	N/A	D
Centrif Duo DP/HTP	220	61	130	36	90	25	60	41	9	51.8	38	21.5	D

Centrif Duo Plus

- Meets current Building Regulations Approved Document F
- Optional filter available
- Easy installation
- Fan can be wall or ceiling mounted
- Suitable for both kitchen and utility rooms
- Constant trickle boost speed available on DP & HTP models
- IPX4 Rated



Ultra Quick Ventilation

Centrif Duo Plus is designed to provide extraction levels that comply with Building Regulations Approved Document requirements, with special humidity sensing variants for local authority use.

The Centrif Duo Plus is for kitchens and utility rooms and large bathrooms. Surface mounting directly into standard 100mm diameter ducting, through the wall or ceiling installation.

Fast Installation

The Centrif Duo Plus has a 100mm circular spigot. The Flush mounting kit enables the spigot to be converted to a side outlet.

The spigot also encloses a built-in, spring operated back draught shutter. The Centrif Duo Plus Range can be wall mounted using a telescopic wall fitting kit available as an accessory (requires a 115mm diameter hole). For ceiling applications the range is ducted either through a soffit outlet or roof cowl assembly. There is convenient access for wiring which accommodates surface or recessed installation.

Improved Humidistat Control

Humidistat is selectable for either kitchen or utility speed separate to any other control to reduce nuisance noise. Boost operation by pullcord or switch live.

Models

Centrif Duo Plus P (Pullcord)

Two speed kitchen extract fan with pullcord. Choice of two speeds for boost, set at installation.

Model	Stock Ref
P	431613

Centrif Duo Plus T (Timer)

Two speed with adjustable timer between 2-30 minutes. Choice of two speeds for boost, set at installation.

Model	Stock Ref
T	431614

Centrif Duo Plus DP (Two speed)

Two speed and Off with pullcord or remote switch. Switches between Off, low and one of the 2 boost speeds.

Model	Stock Ref
DP	431615

Centrif Duo Plus HTP (Humidity/ Timer/ Pullcord)

Intermittent on 1 of 2 speeds (Utility or Kitchen selectable at installation). Operation by integral humidity sensor or pullcord. Separate speeds selectable for humidistat and pullcord. Optional continuous trickle speed available at installation.

Model	Stock Ref
HTP	431616

Accessories

Flush Mounting Kit

Bezel, clips and 90° duct elbow reduces the need to make good.

Model	Stock Ref
Flush Mounting Kit	439256

Model	Stock Ref
Centrif Duo Plus Filter	439927
Wall Kit White	254102
Wall Kit Brown	254100
Decoration Frame	442551

Dimensions (mm)

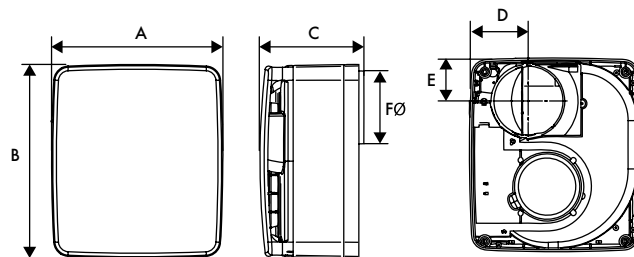

A	B	C	D	E	FØ
231	261	140	79	58	98

Weight 1.75kg

Performance Guide

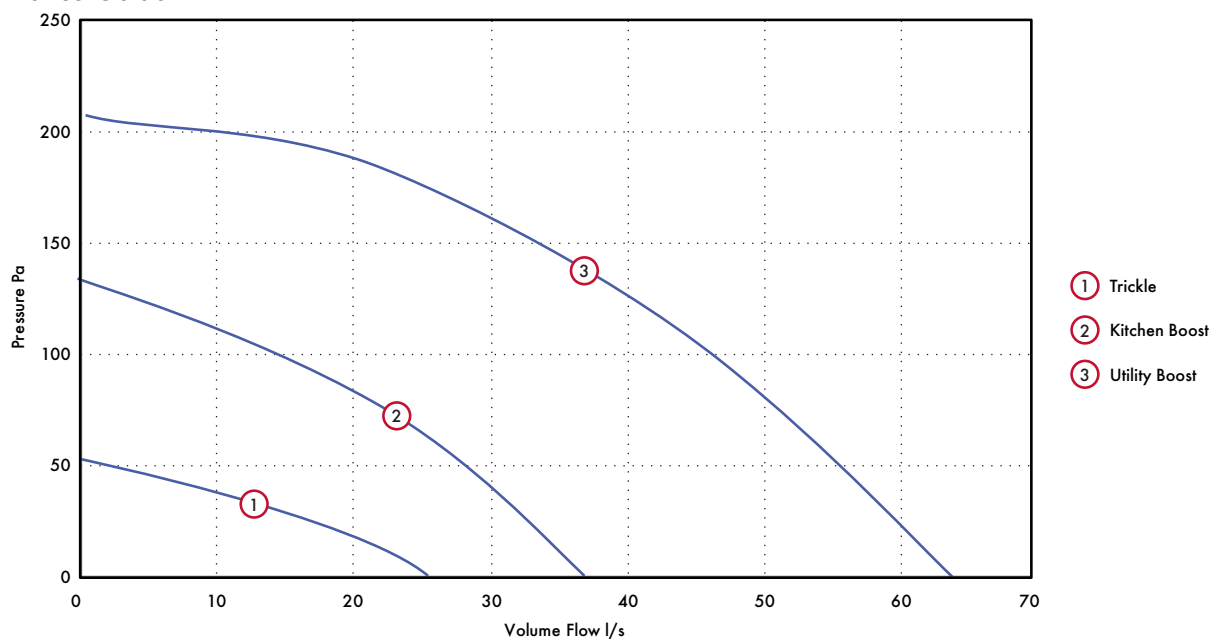

Performance @ 0 Pa

Model	High speed		Med speed		Low speed		Power (W)			Sound dB(A) @3m			SEC Class
	m ³ /h	l/s	m ³ /h	l/s	m ³ /h	l/s	Kitchen	Utility	Trickle	Kitchen	Utility	Trickle	
Centrif Duo Plus P/T	220	61	130	36	-	-	60	41	N/A	51.8	38	N/A	D
Centrif Duo Plus DP/HTP	220	61	130	36	90	25	60	41	9	51.8	38	21.5	D

Freshvent

- Completely silent, all year round ventilation
- Complements existing ventilating fans
- Filtered, natural air without draughts
- Control of the indoor environment
- Helps prevent damaging condensation
- No energy consumption, no running costs

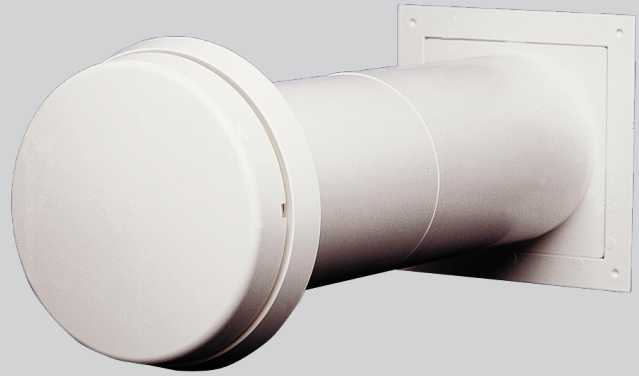

Natural Ventilation

Freshvent 100 is a range of passive ventilators that simply and naturally provide the effective ventilation needed by everyone working and living in an indoor environment. When used with positive pressure ventilation, Freshvent 100 provides an important outlet for air circulating around the house. Stale air is expelled through the unit to the outside without letting in noise and draughts.

This makes Freshvent 100 particularly suited to the 'tight' construction of new homes - and provides a stylish alternative to traditional slot/airbrick ventilators. In addition, Freshvent 100 is ideal for older properties that have been refurbished with double glazing and loft insulation. They require ventilation to combat the problems associated with condensation.

Kitchens, utility rooms, bathrooms and toilets are rooms where conventional domestic extract fans are normally found. The natural ventilation principle of Freshvent 100 is particularly suitable for 'clean' living spaces such as bedrooms, lounges and work rooms.

There are four Vent-Axia Freshvent 100 models and an extensive range of accessories available to customise the units to your exact requirements. All units are easily dismantled allowing quick access to the filter for cleaning or replacement. The high capacity of the filter results in fewer filter changes. The damper plate is insulated against condensation and noise penetration.

Acoustic Duct Versions

Acoustically damped pipe fitted around unit to reduce external sources of noise such as traffic. Suitable for bedrooms and other rooms where low noise levels are a priority. Comes complete with Freshvent 100 dB and Freshvent 100 Thermo dB versions.

Free Area

Product	Equivalent free area mm ²
Fresh 100	3200
Fresh 100 dB	3200
Fresh 100 Thermo	2640
Fresh 100 Thermo dB	2640

Models

Freshvent 100

Pullcord operated. Designed to provide filtered air from outdoors while mixing it efficiently with the air in the room. Adjustable to increase or reduce the free area and airflow to suit a particular environment.

Model	Stock Ref
100	453200

Freshvent 100 dB

Pullcord operated. Adjustable to increase or reduce the free area and airflow to suit a particular environment. Supplied with acoustically damped pipe for applications requiring low noise levels.

Model	Stock Ref
100 dB	453208

Freshvent 100 Thermo

Thermostatically regulated, with the vent size automatically adjusting according to the temperature outside. As the temperature decreases the damper closes, opening again as the temperature rises. The built-in thermostat regulates the size of the damper opening so that it starts to close at 10°C and is completely closed at -5°C.

Model	Stock Ref
100 Thermo	453182

Freshvent 100 Thermo dB

Thermostatically regulated, with the vent size automatically adjusting according to the temperature outside. As the temperature decreases the damper closes, opening again as the temperature rises. The built-in thermostat regulates the size of the damper opening so that it starts to close at 10°C and is completely closed at -5°C. Supplied with acoustically damped pipe for applications requiring low noise levels.

Model	Stock Ref
100 Thermo dB	453253

All versions come with a standard general duty filter. Replacement filters are available.

Accessories

Model	Stock Ref
Filter for Freshvent 100	453188
Filter for Freshvent 100 Thermo	453197
Extension Bushing	453275

Storm Shield

May be fitted to the Freshvent range to prevent ingress of water and eliminate the risk of draughts and cold air surges. Closes entirely during storms. Particularly suitable for high-rise/coastal applications or anywhere exposed to high winds.

Not suitable for dB models.

Model	Stock Ref
Storm Shield	453206

Dimensions (mm)

Model	Wall fixing hole dia Ømm	Max wall thickness mm
Freshvent 100	100	360
Freshvent 100 dB	150	400
Freshvent 100 Thermo	100	320
Freshvent 100 Thermo dB	150	400

Basics Range



Bathroom/Toilet

BAS100B

Unshuttered axial fan for remote or light switch operation.

Stock Ref

436519

BAS100P

Unshuttered axial fan with integral pullcord.

Stock Ref

436520

BAS100T

Unshuttered axial fan with adjustable overrun timer.

Stock Ref

436521



Kitchen

BAS150B

Unshuttered axial fan designed for remote or light switch operation.

Stock Ref

436525

BAS150P

Unshuttered axial fan with integral pullcord.

Stock Ref

436526

BAS150T

Unshuttered axial fan with adjustable overrun timer.

Stock Ref

436527

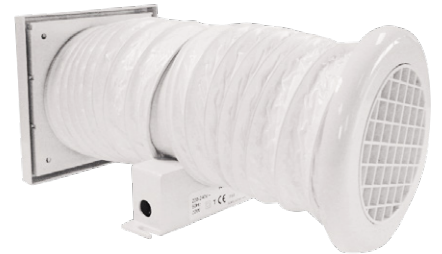

Shower Fan & Kit

The kit consists of a IP44 In-Line fan, a white ceiling grille and spigot, 3 meters of flexible duct and an external louvre for soffit or wall mounting.

Minivent SK

Single speed 100mm in-line axial fan.

Stock Ref

248710

Minivent SKT

Single speed 100mm in-line axial fan with integral adjustable overrun timer - 5-30 minutes.

Stock Ref

248810



BAS100SLB

Single speed axial fan with integral back draught shutter for remote or light switch operation.

Stock Ref

436530

BAS100SLT

Single speed axial fan with electronic overrun timer (5-30 minutes) and integral back draught shutter.

Stock Ref

436532



BAS150SLB

Single speed axial fan with integral back draught shutter for remote or light switch operation.

Stock Ref

436533

BAS150SLT

Single speed axial fan with electronic overrun timer (5-30 minutes) and integral back draught shutter.

Stock Ref

436535

Eclipse 100 & 150

- Wall or ceiling mountable
- Integral back draft shutter mechanism
- Meets current Building Regulations Approved Document F
- 100mm and 150mm size options
- Fixing kits available
- Fan IP44 rated -100mm
- Fan IPX4 rated -150mm



Bathroom Ventilation

The Eclipse range of circular axial fans is designed to be installed in kitchens and bathrooms. Its simple design provides an unobtrusive fitting that is sympathetic with most interiors.

Models

ECLIPSE 100X

Single speed 100mm bathroom/toilet fan with back draught shutter.

Model	Stock Ref
100X	427310

ECLIPSE 100XP

Single speed 100mm bathroom/toilet fan with pullcord and back draught shutter.

Model	Stock Ref
100XP	427281

ECLIPSE 100XT

Single speed 100mm bathroom toilet fan with integral adjustable overrun timer (5-30 minutes) and back draught shutter.

Model	Stock Ref
100XT	427282

ECLIPSE 150X

Single speed 150mm kitchen fan with back draught shutter.

Model	Stock Ref
150X	427283

ECLIPSE 150XP

Single speed 150mm Kitchen fan with pullcord and shutter.

Model	Stock Ref
150XP	427313

Accessories

Model	Stock Ref
Bezel Chrome 100mm	436480
Bezel Silver 150mm	436483
Wall Kit White 150mm	140902
Wall Kit Brown 150mm	140903
Wall Kit White 100mm	254102
Wall Kit Brown 100mm	254100

Dimensions (mm)

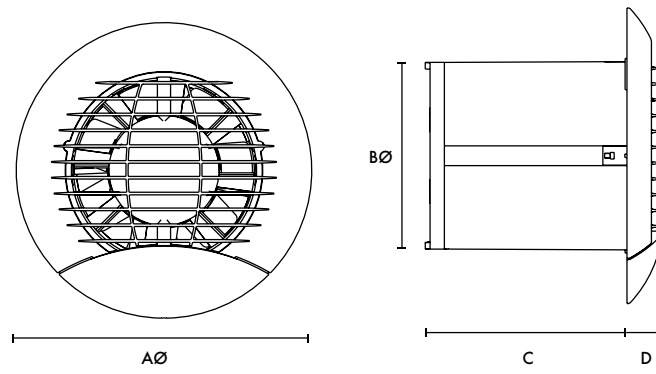

Model	AØ	BØ	C	D
Eclipse 100	157	99	107	19
Eclipse 150	201	144	123	19

Performance

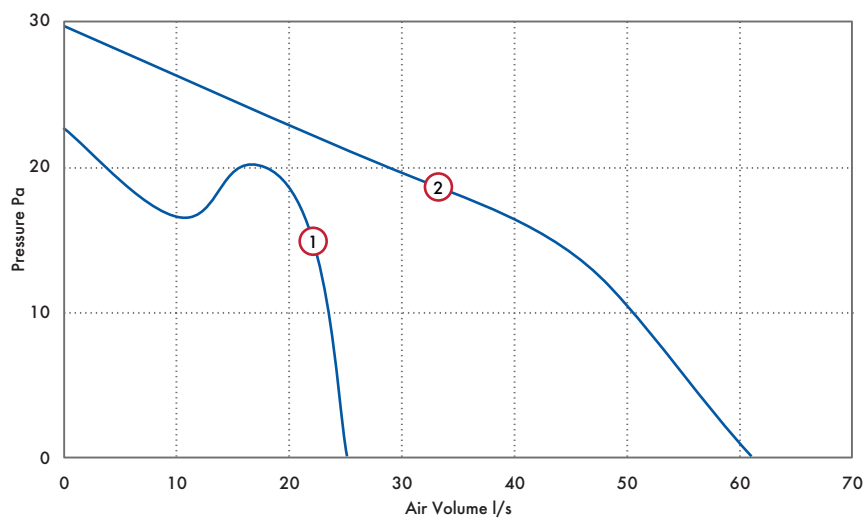

Model	Curve Ref	Extract Performance			dB(A) @ 3m	SFP (W/l/s) @ 0Pa
		m ³ /h	l/s	Watts		
Eclipse 100	①	90	25	15	38	0.49
Eclipse 150	②	220	61	20	45	0.25

Tested at 240V 50Hz

dMEV, MEV & PIV Systems



What is dMEV & MEV?

The latest Building Regulations Approved Document F gives examples of three main methods of ventilation. Continuous mechanical extract ventilation, can be achieved using a single centralised extract unit such as the Sentinel Multivent ducted from 'wet' rooms (kitchen, bathroom, en-suite and WC) or by decentralised individual fans (dMEV) in the 'wet' rooms. The fans run continuously at near silent levels providing a simple and effective form of ventilation.

NEW Lo-Carbon Response 7

The intelligent Lo-Carbon Response 7 is a NEW filterless unitary fan designed to meet the specific needs of social housing. Boasting powerful, quiet, efficient ventilation, the Response 7 provides good indoor air quality and comfort for residents while being quick and easy to install, low maintenance and reliable.

Smart Sense™ Technology

Featuring Smart Sense™ intelligent technology Response 7 is quick and easy to install due to its simple alpha numeric LED display which is clear, easy to read and has a three-button menu for commissioning and data gathering.

Vent-Axia





NEW Lo-Carbon NBR dMEV C

D:3-D:4



Lo-Carbon Centra®/SELV
dMEV Unit

D:5-D:6



Lo-Carbon Response 7/SELV
dMEV Unit

D:7-D:8



Lo-Carbon Sentinel® Multivent/Plus
MEV Unit

D:9-D:12



Lo-Carbon MVDC-MS/MSH Multivent
MEV Unit

D:13-D:14



Lo-Carbon NBR dMEV/dMEVe

D:15-D:16



Lo-Carbon PoziDry Pro™
Positive Input Ventilation

D:17-D:18



Lo-Carbon PoziDry Compact
Positive Input Ventilation

D:19-D:20

Lo-Carbon NBR dMEV C

- Continuously running 100mm and 125mm dMEV with sleek circular design
- Designed to comply with the latest Building Regulations Parts L1A and F 2021
- SAP PCDB listed with SFP's down to 0.08 W/l/s
- Near silent operation independently tested
- IPX5 rated, wall and ceiling mounted Zones 1, 2 and 3
- Low ceiling void - 56mm (100mm spigot) and 66mm (125mm spigot)
- Easy to commission, fully adjustable variable control platform
- Intelligent humidistat option with proportional speed increase and timer
- Comfort control option
- 7-year warranty

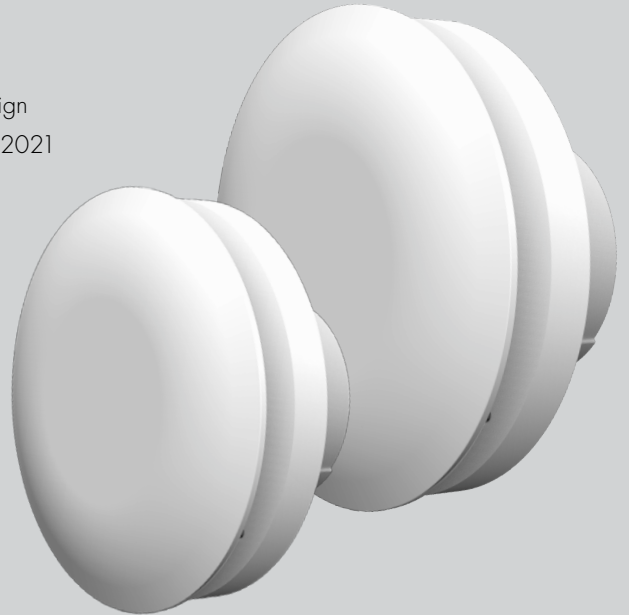

Lo-Carbon NBR dMEV C

Increased whole ventilation rates, should not mean increased noise levels. The Vent-Axia Lo-Carbon NBR dMEV C fan, available in 100mm and 125mm, provides adequate ventilation whilst minimising noise.

The fan is designed in line with the Approved Document F 2021 Building Regulations, meeting the increased whole house ventilation rates.

Table 1.3 - Minimum whole dwelling ventilation rates determined by the numbers of bedrooms.

No. of bedrooms	2013 Edition	2021 Edition	Increase
1	13l/s	19l/s	46%
2	17l/s	25l/s	47%
3	21l/s	31l/s	47%
4	25l/s	37l/s	48%
5	43l/s	43l/s	48%

The minimum whole dwelling ventilation rate for the supply air should meet the higher of the two following result:

- A minimum rate of 0.3l/s per m² of internal floors area
- A minimum rate determined by the number of bedroom, as per Table 1.3

Nuisance tripping has also been minimised within the fan logic. The integral humidity sensor versions have functionality that allows for proportional speed increase up to 85% relative humidity (RH) before enabling Boost.

The Lo-Carbon NBR dMEV C is complete with IPX5 rating, allowing flexible installation within Zone 1, 2 and 3.

A back pressure detection system option is available, to Boost if the system pressure increase momentarily due to external wind conditions. A silent mixed flow impeller means the Lo-Carbon NBR dMEV C can meet the requirements of many domestic installations without the need to use a traditional centrifugal fan.

A brand new control platform also provides fully adjustable airflow, meaning wholehouse rates can be achieved easily using fewer fans.

Comfort Control Option

Designed to offer a more relaxing environment to the homeowner, the Lo-Carbon NBR dMEV C features a delayed start. This patented comfort control option allows the homeowner to enjoy a quiet, peaceful bathroom for up to 20 minutes before the Boost activates. Furthermore, if the light switch turns On and Off within three minutes, the Boost will not activate. No more disturbing the family if the bathroom light is turned on during the night.

Near Silent Operation

The fan has been designed to be as discreet as possible for homeowners, with independently tested sound levels as low as 11.3dB(A) at 6l/s.

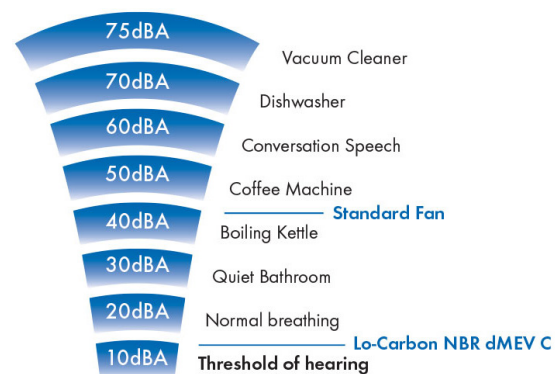

Model

Lo-Carbon NBR dMEV C

For kitchen, utility and bathroom/toilet applications, the continuous running dMEV C fan is available as standard or as a humidistat model which incorporates an ambient response humidistat. The fan will increase the extract rate if the humidity rises above the point set at installation. Both fans will have optional Comfort Control, which includes a timer function.

Variable speed setting

Model	Stock Ref
Lo-Carbon NBR dMEV C 100	498095
Lo-Carbon NBR dMEV C 100 H	498096

Variable speed setting

Model	Stock Ref
Lo-Carbon NBR dMEV C 125	498097
Lo-Carbon NBR dMEV C 125 H	498098

Accessories

Model	Stock Ref
Wall Kit White 100mm	254102
Wall Kit Brown 100mm	254100
Wall Kit White 125mm	455226
Wall Kit Brown 125mm	497434
Wall Kit Terracotta 125mm	497432

Consultant Specification

The de-centralised mechanical extract ventilation unit shall be the Lo-Carbon NBR dMEV C as manufactured by Vent-Axia, exact unit sizing and specification shall be in accordance with the particular specification.

The range should consist of IPX5 rated 100mm and 125mm sizes to meet the Building Regulations compliant design, extracting air from wet rooms (including kitchen and utility) via rigid, flexible ducting or through-wall applications with the fewest fans possible, supplied with a 7 - year warranty.

The 100mm Lo-Carbon NBR dMEV C should have variable speed settings of 5-26 l/s achieving a minimum noise level of 7.4dB(A) at 3 metres. The 125mm Lo-Carbon NBR dMEV C should have variable speed settings of 5-35 l/s achieving a minimum noise level of 8.5dB(A) at 3 metres. All sound pressure levels are quoted at hemispherical measurements. All units shall be and independently third-party tested at the Sound Research Laboratory (SRL), tested to BS EN 13141-6.

The unit shall comprise a single high efficiency EC/DC motor to deliver specific fan powers as low as 0.08 W/l/s, as measured in accordance with the SAP PCDB test method and listed on the PCDB database.

The controls for the Lo-Carbon NBR dMEV C unit shall provide fully adjustable, continuous whole house ventilation rates. The Boost speed shall be activated via an integral humidistat or via LS Input.

The fan shall be compatible with low ceiling voids and have a spigot length of 56mm (100mm) and 66mm (125mm).

The fan shall have the nuisance tripping prevention option called Comfort Control, which stops the fan from engaging Boost when the LS input is engaged for less than three minutes.

The unit shall be able to be commissioned as a continuous running fan according to the Building Regulations compliant design.

Dimensions (mm)

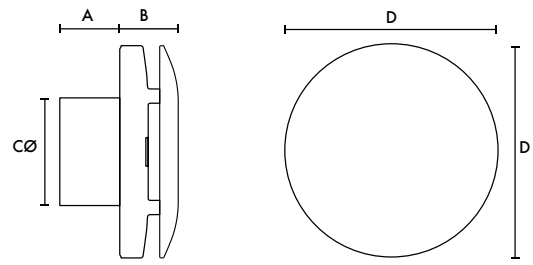

Model	A	B	CØ	D
100	56	54	99	195
125	66	57	120	228

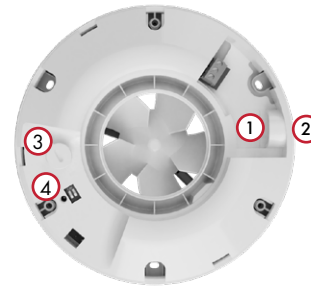

- ① Rear cable entry
- ② Side cable entry (cut plastic side wall to access)
- ③ 100% variable speed adjustment
- ④ Installation mode (SW1) Back pressure detection system (SW2)

Performance Guide

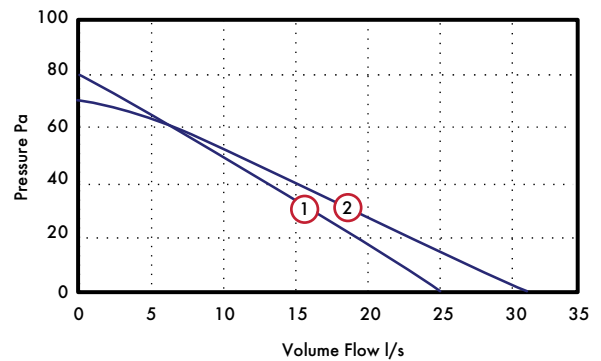

- ① 100mm dMEV C Max Speed
- ② 125mm dMEV C Max Speed

Sound

Model	Speed	dB(A)
100	Min	7.4
	Max	34.3
125	Min	8.5
	Max	37.9

SAP PCDB Performance 2021

Unit configuration	Location	100 Model	125 Model
In room (Rigid duct)	Kitchen (13l/s)	0.14	0.14
	Kitchen/wet room (8l/s)	0.11	0.12
Through wall	Kitchen (13l/s)	0.08	0.09
	Kitchen/wet room (8l/s)	0.08	0.10

Lo-Carbon Centra/SELV

- Building Regulations Approved Documents F and L compliant
- Continuous mechanical extract
- Recognised in SAP PCDB - Low SFP
- Discreet, tasteful styling
- IPX4 rated - IPX7 rated (SELV)
- dMEV Pressure detection device
- 5 year motor warranty
- Suitable for wall, ceiling, panel and window mounting
- SELV models supplied with remote transformer and suitable for 'Zone 1'



the ELECTRICAL
industry awards
WINNER 2011

Winners of the Energy Efficiency Initiative 2011 Award
with our Lo-Carbon Continuous Ventilation Product Range

What is de-centralised MEV (dMEV)?

Building Regulations Approved Document F gives examples of three main methods of ventilation. Continuous mechanical extract ventilation, can be achieved using a single centralised extract unit such as the Sentinel Multivent ducted to 'wet' rooms (kitchen, bathroom, en-suite and WC) or by decentralised individual fans, such as the Lo-Carbon Centra in the 'wet' rooms. The fans run continuously at near silent levels providing a simple and effective form of ventilation.

SELV (Safety Extra Low Voltage) is designed for areas where a fan can be installed within Zone 1 in a room where there is a fixed bath or shower. Ingress Protected (IP) to IPX7 Lo-Carbon Centra SELV can be fitted safely within the spray area. The separate transformer can be mounted away from the spray zone and out of reach from the bath or shower.

The Lo-Carbon Centra meets the latest requirements of the Building Regulations Approved Document F for wholehouse system ventilation and all models come with a 5 year motor warranty.

Selection of the two trickle flow rates (6l/s or 9l/s) is via a simple 'jumper' on the control board. Different methods are available for operating the 15 l/s boost speed from a simple switched live to integral humidistat. See individual models for further details.

The attractive and discreet styling of the Vent-Axia Lo-Carbon Centra will complement the décor of any new home while virtually silent operation ensures optimum ventilation is achieved without intrusive noise.

Specific Fan Power

dMEV version recognised in SAP PCDB. Lo-Carbon Centra has a specific fan power of only 0.18 W/l/s in through-the-wall kitchen applications.

Models

Lo-Carbon Centra dMEV

Auto speed selection at installation and suitable for bathrooms or kitchens. The integral air pressure sensor checks the airflow when first installed and also helps the fan to compensate for external wind pressure.

Stock Ref

441782

Lo-Carbon Centra T/SELV T (Timer)

Ideal for bathroom and toilet applications, this unit runs continuously on trickle setting and may be boosted by the switched live input which activates the timer (fixed 15 min on T models, adjustable 5-30 minutes on SELV models).

Model

Stock Ref

T

473825

SELV T

443175

Lo-Carbon Centra TP/SELV TP (Timer/Pullcord)

For bathroom/toilet applications, the continuous running TP model is boosted by the pullcord which activates the timer (fixed 15 min on TP models, adjustable 5-30 minutes on SELV models).

Model

Stock Ref

TP

473826

SELV TP

447128

Lo-Carbon Centra HT/SELV HT (Humidistat/Timer)

For bathroom/toilet applications, the continuous running HT model is automatically boosted by the built-in humidistat or by a switched live input which activates the timer (fixed 15 min on HP models, adjustable 5-30 minutes on SELV models).

Model

Stock Ref

HT

473827

SELV HT

443176

Lo-Carbon Centra HTP/SELV HTP (Humidistat/Timer/Pullcord)

For bathroom/toilet applications, the continuous running HTP model is automatically boosted by the built-in humidistat or by the pullcord which activates the timer (fixed 15 min on HTP models, adjustable 5-30 minutes on SELV models).

Model	Stock Ref
HTP	473828
SELV HTP	443177

Dimensions (mm)

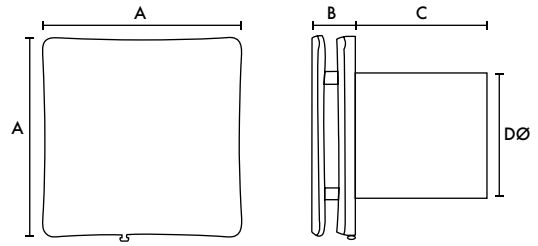

Model	A	B	C	DØ
Lo-Carbon Centra dMEV/All SELV	160	35	115	99
Lo-Carbon Centra T/TP/HT/HTP	160	35	115	99

Transformer 87 x 87 x 33mm (W x H x D) (SELV models only)

Accessories

Model	Stock Ref
150mm Conversion Kit	443334
Wall Kit White	254102
Wall Kit Brown	254100
Window Kit	442947
Ceiling Kit	443800

Performance Guide

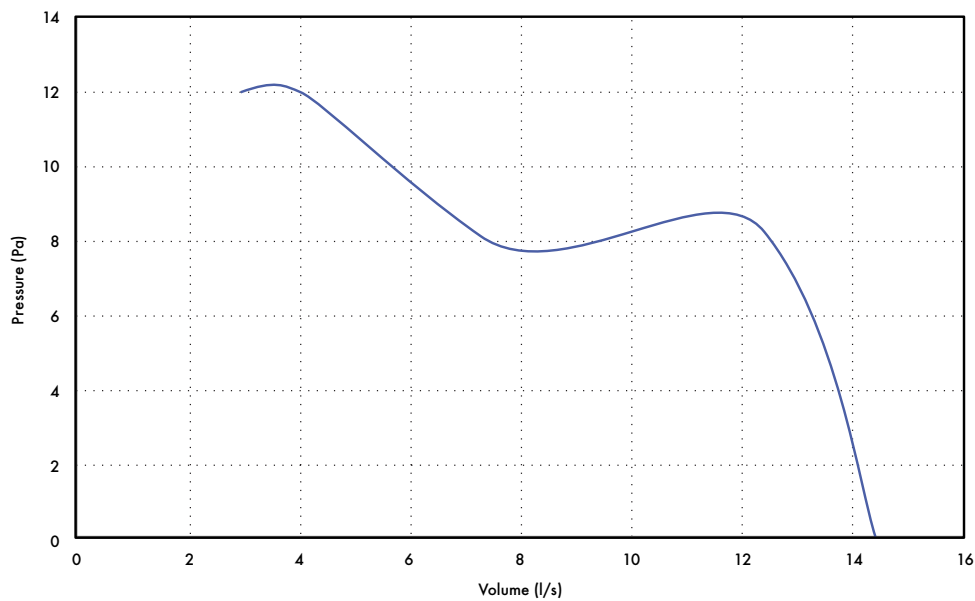

Model	Extract Performance (l/s)			Power Consumption (Watts)			Sound dB(A)@ 3m		
	Trickle	Trickle	Boost	Trickle	Trickle	Boost	Trickle	Trickle	Boost
	Low	High		Low	High		Low	High	
Lo-Carbon Centra dMEV/All SELV	6	9	15	1.4	1.6	2.4	10.8	15.5	25.2
Lo-Carbon Centra T/TP/HT/HTP	6	9	15	3.2	3.5	4.2	10.8	15.5	25.2

SAP PCDB Performance (dMEV model)

Systems With Rigid Ductwork Installation

Unit Configuration	Location	Fan Speed Setting	Flow Rate (l/s)	SFP (W/l/s)
In Room (Ducted)	Kitchen	High	13.2	0.32
In Room (Ducted)	Wet Room	9 l/s	8.4	0.28
Through Wall	Kitchen	High	13.5	0.18
Through Wall	Wet Room	9 l/s	8.6	0.20

Systems With Flexible Or Mixed Ductwork Installation

Unit Configuration	Location	Fan Speed Setting	Flow Rate (l/s)	SFP (W/l/s)
In Room (Ducted)	Kitchen	High	13.2	0.37
In Room (Ducted)	Wet Room	9 l/s	8.6	0.31
Through Wall	Kitchen	High	13.5	0.18
Through Wall	Wet Room	9 l/s	8.6	0.20

NEW Lo-Carbon Response 7/SELV

- Designed especially for Social Housing
- Ultra low profile for discreet installation
- Continuous running fan
- 7 year warranty
- High performance on trickle to avoid going to boost too often
- Intelligent Smart Sense™ technology tells you days run, boost hours run, energy used
- IP45 Rated - IPX7 on SELV models
- Small footprint with optional decoration frame
- Unique settings lock to prevent tampering
- 100 & 125mm models



Designed for Social Housing

The intelligent Lo-Carbon Response 7 is a NEW filterless unitary fan designed to meet the specific needs of social housing. Boasting powerful, quiet, efficient ventilation, the Response 7 provides good indoor air quality and comfort for residents while being quick and easy to install, low maintenance and reliable.

Smart Sense™ Technology

Featuring Smart Sense™ intelligent technology Response 7 is quick and easy to install due to its simple alpha numeric LED display which is clear, easy to read and has a three-button menu for commissioning and data gathering. Smart Sense™ technology even tells the LED display which orientation to use depending on whether it is wall or ceiling mounted. All of which saves time on site and reduces installation complications. The Response benefits from a unique settings lock to prevent tampering with the unit; giving the landlords peace of mind.

The display also shows real-time data so landlords can reassure residents of the low-running costs. This includes data such as days run, hours on trickle or boost, and even more specifically, hours run on boost triggered by the humidity sensor. Response can also tell you how much energy the fan has used.

Side View of Airflow Display

Be confident that the Response 7 is delivering the right performance with our innovative digital display showing the airflow and system pressure of the installed product.



Comfort Control Option

Designed to offer a more relaxing environment to the homeowner, the Lo-Carbon Response 7 features a delayed start option. This new, patented, comfort control option is selectable at installation and allows the resident to enjoy a quiet, peaceful bathroom for up to 20 minutes before the Boost activates, drastically improving resident acceptability. Furthermore, if the light switch turns On and Off within 3 minutes, the Boost will not

activate. No more disturbing the family if the bathroom light is turned on during the night.

Model

Lo-Carbon Response 7/SELV

A discreet and intelligent HTP bathroom specifically designed for social housing. Day logger and power run meter as standard. 7 year warranty. Built-in lock function. Adjustable dynamic ambient response humidity sensor. Timer adjustable between 1 and 30 minutes. In built boost activated by pullcord, humidity sensor, switched live or remote button. Tile front for discreet installation.

Variable Speed Settings (5-30 l/s trickle, 6-35 l/s boost).

Model	Stock Ref
Response 7 100	494143
Response 7 100 SELV	494150

Variable Speed Settings (9-30 l/s trickle, 10-35 l/s boost).

Model	Stock Ref
Response 7 125	496738

Lo-Carbon Response 7 Pro/SELV

A discreet and intelligent HTP bathroom specifically designed for social housing. Day logger and power run meter as standard. 7 year warranty. Built-in lock function. Adjustable dynamic ambient response humidity sensor. Timer adjustable between 1 and 30 minutes. In built boost activated by pullcord, humidity sensor, switched live or remote button. Tile front for discreet installation. Constant volume for accurate installed performance.

Variable Speed Settings (5-30 l/s trickle, 6-35 l/s boost).

Model	Stock Ref
Response 7 100 Pro	494144
Response 7 100 Pro SELV	494149

Variable Speed Settings (9-30 l/s trickle, 10-35 l/s boost).

Model	Stock Ref
Response 7 125 Pro	496689

Accessories

Model	Stock Ref
100mm Internal Fit Wall Kit White	472318
100mm Internal Fit Wall Kit Brown	472319
100mm to 150mm Conversion Kit	408680
100mm Ceiling Kit	407928
100mm Window Kit	407927
100mm Decoration Frame	474041
125mm Wall Kit White	455226

SAP PCDB Performance

Unit Configuration	Location	100 Model	125 Model
In room (rigid duct)	Kitchen	0.17	0.16
	Wet room	0.17	0.20
In room (flex-duct)	Kitchen	0.16	0.15
	Wet room	0.16	0.20
Through wall	Kitchen	0.12	0.12
	Wet room	0.14	0.16

Dimensions (mm)

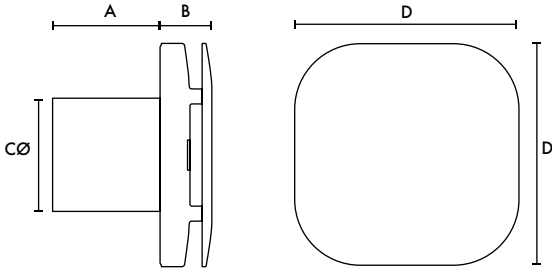

Model	A	B*	CØ	D
100	81	43	99	190
125	100	46	115	213

100mm Decoration Frame Dimensions (mm)

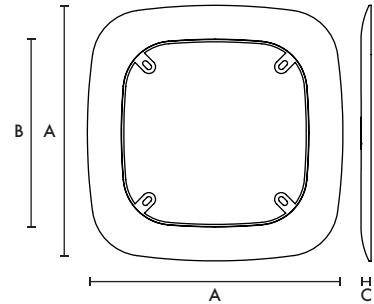

A	B	C
259	191	10

Performance Guide

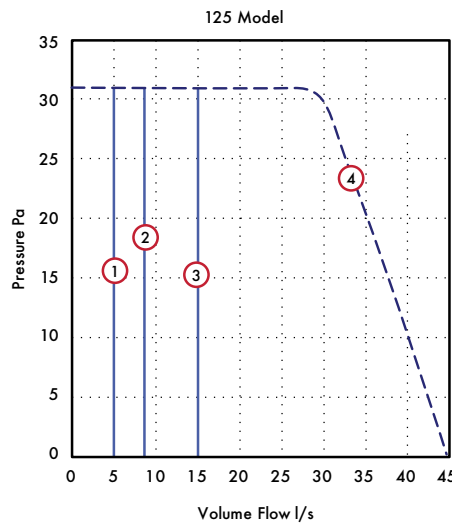
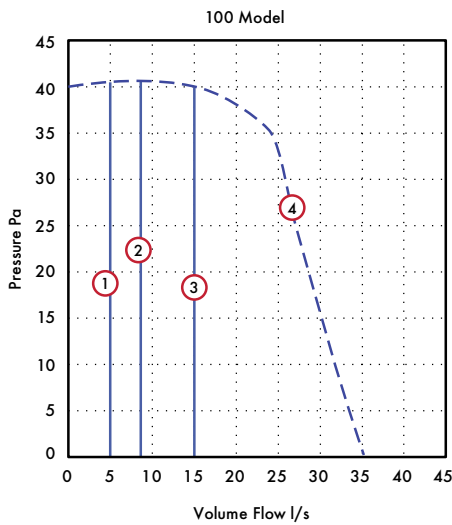

- ① 5l/s Constant Volume
- ② 9l/s Constant Volume
- ③ 15l/s Constant Volume
- ④ Maximum pressure available to deliver airflow

Extract Performance - FID

Model	Air Performance (l/s)	m ³ /h	Watts	Sound dB(A) @ 3m
100	5	18	1	13.2
	9	32	1.2	17.3
	15	54	1.6	23.9
	35	126	8.3	41.2
125	5	18	1	12
	41	148	10.7	36

Lo-Carbon Sentinel Multivent/Plus

- Reduces your carbon footprint
- Recognised in SAP PCDB
- Specific fan power as low as 0.16 W/l/s
- Suitable for use with external sensors and controllers
- Wireless control option for "X" models
- Complies with Building Regulations ADF and ADL
- Manufactured in the UK



Sentinel Multivent continuous mechanical extract ventilation, MEV is designed for the simultaneous ventilation of separate areas in the home or as a multipoint extraction system for a wide range of commercial applications. The units can be wall, ceiling or loft mounted. Where the ambient air has a high humidity content condensate drains are provided.

In support of Sentinel Multivent, Vent-Axia offers:

- Practical advice on product selection and installation
- Guidance on solutions to meet legislation requirements
- Project management and site deliveries
- After sales support and maintenance information

The need to improve efficiency

Sentinel Multivent has been designed to meet the exacting demands of developers, installers and users offering advanced control options and easier installation and commissioning.

- Demand Control - enables precise ventilation rate, is set in 1% increments based on property size
- Comfort mode allows homeowners to control when the unit runs and for how long to avoid disturbance
- Integral digital display allows the installer to select appropriate low, normal, boost and purge speeds to meet demand
- Manual and automatic control options
- Integral adjustable overrun timer and delay on timer
- Switched live and SELV connections
- Optional Wireless Control on "X" units
- Energy efficient EC/DC motors - 1/3 less energy lost to heat than a conventional AC motor
- Low Specific Fan Power (SFP) making it one of the most efficient products on the market

Legislation

- Meets Building Regulations Approved Document F (System 3)
- Recognised in SAP PCDB up to kitchen + 6 wet rooms
- Meets carbon footprint reduction targets
- The need for better health: Removal of pollutants such as moisture, carbon dioxide and external fumes are all important factors

in maintaining indoor air quality, helping to create a healthier living environment

- The integral humidity sensor (Sentinel Multivent H) increases fan speed in proportion to relative humidity levels, saving energy and reducing noise
- The sensor also reacts to small but rapid increases in humidity, even if the normal trigger threshold is not reached. This unique feature ensures adequate ventilation, even for the smallest wet room
- Night time relative humidity increment setback feature suppresses nuisance tripping as humidity gradually increases with falling temperature

SAP PCDB

In order to make the right choice, developers and contractors should refer to Building Regulations ADL1a, SAP 2012 and SAP PCDB.

SAP PCDB was launched in June 2006 to reward innovative ventilation manufacturers by testing and listing energy efficient products that assist in helping developers meet their Target Emission Rates (TER).

SAP is the underpinning methodology behind the Energy Performance Certificates and is used to demonstrate compliance with Building Regulations for Dwellings - Approved Document L (England and Wales), Section 6 (Scotland) and Approved Document F (Northern Ireland). SAP PCDB specifically relates to wholehouse ventilation systems and lists a number of Vent-Axia Mechanical Ventilation solutions which offer an improved SAP rating over and above the default for these product types.

SEC Class

Model	SEC Class (inc. LDC)
Sentinel Multivent/Plus	B

SAP PCDB Test Results (Sentinel Multivent and Multivent Plus)

Exhaust Terminal Configuration	Total Flow Rate (l/s)	SFP (W/l/s)
K+1	21	0.17
K+2	29	0.16
K+3	37	0.17
K+4	45	0.18
K+5	53	0.21
K+6	61	0.24

To assist developers and contractors Vent-Axia can provide detailed scheme designs together with installation guidance and training.

Your Carbon Footprint

Carbon footprint is a measure of the amount of carbon dioxide (CO²) emitted through the burning of fossil fuels. From a residential and commercial building perspective, it is the amount of carbon generated when you consume a kiloWatt (kW) of electricity. Reducing a building's carbon footprint will ultimately reduce electricity bills and save money for every individual household or business. It will also help meet the UK target for the reduction of emissions, as well as allowing you to help the environment.

Model

	Stock Ref
Sentinel Multivent H	445655
Sentinel Multivent HX	495360
Sentinel Multivent HX CO ²	495361
Sentinel Multivent Plus H	407849
Sentinel Multivent Plus HX	495362
Sentinel Multivent Plus HX CO ²	495363

Accessories



	Stock Ref
Anti Vibration Mounts (Pack of 4)	68MP033G

See page D:10 for control options.

Dimensions (mm)

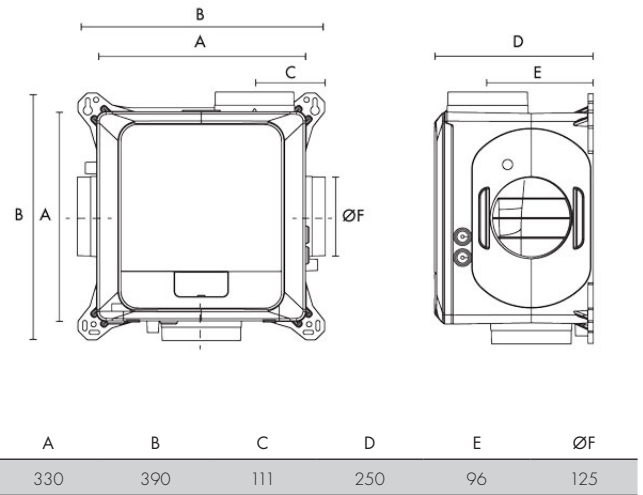

Performance Guide

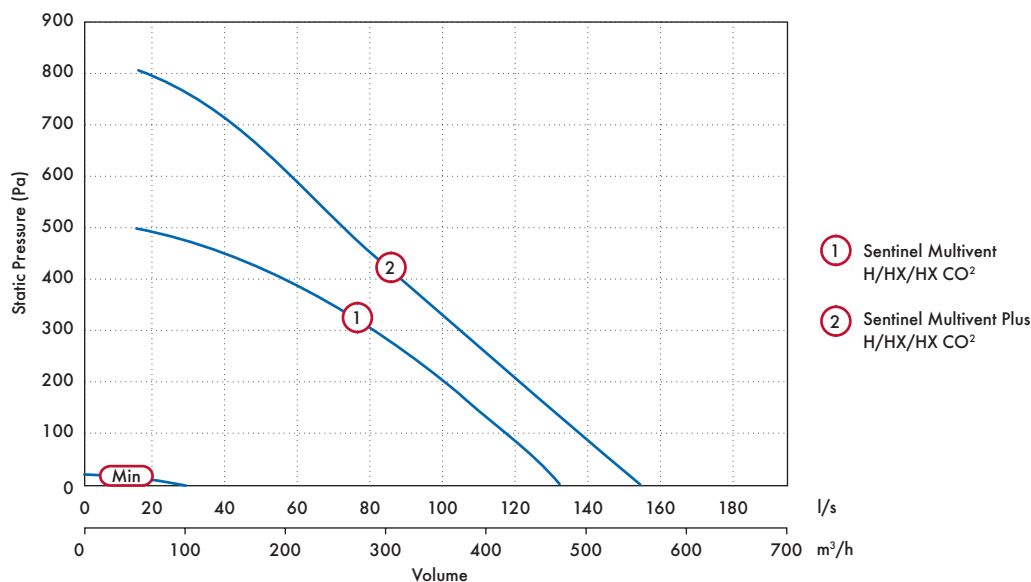

Stock Ref	Model	Curve Ref	FID (l/s)	Power Watts	IP Rating
445655 / 495360 / 495361	Multivent	1 (max)	128	52	IPX2
407849 / 495362 / 495363	Multivent Plus	2 (max)	159	85	IPX2

Sound Data

Model	Speed	Test Mode	Octave Band (Hz) Sound Power Levels, dB								LwA	SpL @ 3m
			63	125	250	500	1k	2k	4k	8k		
Sentinel Multivent	20%	Extract	32.5	50.7	41.9	37.5	28.4	19.4	17.8	22.3	38.0	20.5
		Breakout	28.7	37.6	32.5	29.6	20.9	14.8	17.9	22.7	30.5	10.0
	40%	Extract	33.4	51.3	52.7	48.2	41.8	38.0	24.0	22.8	49.2	31.7
		Breakout	34.1	52.7	42.6	38.9	30.3	24.8	18.5	22.6	42.0	21.5
	60%	Extract	38.2	53.3	70.5	58.9	49.5	46.0	35.8	27.2	61.5	44.0
		Breakout	44.8	48.4	54.4	45.4	37.6	32.6	23.6	22.8	47.4	26.9
	80%	Extract	41.7	55.5	70.3	60.6	55.3	52.7	43.5	35.9	64.2	46.7
		Breakout	41.8	51.6	61.9	50.9	43.5	39.5	30.3	23.9	55.1	34.6
	100%	Extract	46.3	58.1	75.1	66.7	60.1	58.0	49.1	43.3	70.2	52.7
		Breakout	46.0	54.0	63.2	55.3	47.8	44.6	35.7	27.0	58.3	37.8

Tested according to BS EN 13141-6:2010. Breakout quoted spherical. Extract quoted hemispherical.

Model	Speed	Test Mode	Octave Band (Hz) Sound Power Levels, dB								LwA	SpL @ 3m
			63	125	250	500	1k	2k	4k	8k		
Sentinel Multivent Plus	20%	Extract	30.3	49.6	43.5	40.4	33.2	25.2	18.2	22.4	40.3	22.8
		Breakout	30.5	39.8	35.3	31.3	22.3	16.5	17.9	22.8	32.5	12.0
	40%	Extract	43.5	54.7	60.8	54.5	46.2	42.5	31.0	24.5	54.5	37.0
		Breakout	47.0	49.3	54.0	42.1	33.9	29.1	20.6	22.6	45.7	25.2
	60%	Extract	40.8	55.2	67.0	61.0	54.0	50.9	41.3	33.3	62.1	44.6
		Breakout	40.1	51.2	58.7	48.2	41.3	37.4	28.4	23.5	52.0	31.5
	80%	Extract	45.5	57.6	79.1	66.3	59.7	57.5	48.5	42.7	73.2	55.7
		Breakout	45.6	54.6	64.5	54.7	46.5	44.2	35.2	26.5	59.1	38.6
	100%	Extract	52.7	61.8	71.6	81.8	66.1	62.7	54.0	49.2	77.8	60.3
		Breakout	56.0	56.6	61.2	63.1	51.3	49.0	40.4	31.4	60.9	40.4

Tested according to BS EN 13141-6:2010. Breakout quoted spherical. Extract quoted hemispherical.

Controllers and Sensors

Sentinel Multivent can be used with a wide range of Vent-Axia controllers and sensors. Ranging from integral humidistats, through to wireless controllers to wired remote sensors.

Ambient Response Humidity Sensor

- Pullcord override and indication light
- Changeover relay switch
- Operating range: 30% - 90%RH
- Ambient operating temp. 5°C to 40°C
- 220-240V AC
- Will fit single gang box for surface mounting

Stock Ref

563550



Ecotronic Humidity Sensor

- Set point adjustable
- Maximum switching load 1 Amp inductive
- Pullcord override indicator
- Ambient operating temp. 0°C to 40°C
- Supply voltage 220-240V

Stock Ref

563532



Visonex PIR Sensor

- Fits any UK single gang mounting box
- Adjustable timer overrun (5-25 mins)
- Range of detection up to 10 metres
- Designed to meet IP43
- Ambient operating temp. range 0°C to 50°C

Stock Ref

459623



Air Quality Sensor

- Ambient operating temp. 0°C to 50°C
- DEMKO approved
- Surface mounted
- 1 - 25 min O/R timer
- Supply voltage 220-240V

Stock Ref

563506



Lo-Carbon MVDC-MS/MSH Multivent

- Recognised in SAP PCDB with best in class Specific Fan Power
- Reduces your carbon footprint
- Fitted with three 125mm or nine 90mm diameter extract spigots allowing quick connection to ducts
- Complies with Building Regulations ADF
- Option of wall, ceiling and loft mounting
- Improved controllability
- Two Switched Live connections
- Fully variable normal, purge and boost speeds
- Ultra quiet
- Integral humidistat (H version)



With growing concerns about accurate ventilation of properties, the Lo-Carbon Multivent MVDC range offers the option of 'Close Control' both in the residential and the commercial sectors. With a DC motor the multi speed Lo-Carbon Multivent is one of the most efficient central extract units available.

The units have 3 fully variable speeds: normal, boost and purge. The digital display allows accurate setting of airflow, ensuring exactly the right ventilation rate. Accurate speed control helps minimise noise and energy consumption.

The Multivent H version incorporates a built-in humidity sensor to boost the unit when humidity reaches a certain threshold.

Models

Model	Stock Ref
MVDC-MS	437634
MVDC-MSH	443298
MVDC-MSH Uniflex	498502

SAP PCDB Test Results

Exhaust Terminal Configuration	Total Flow Rate (l/s)	SFP (W/l/s)
K + 1	21	0.15
K + 2	29	0.14
K + 3	37	0.16
K + 4	45	0.18
K + 5	53	0.21
K + 6	61	0.26

Dimensions (mm)

MVDC-MS/H

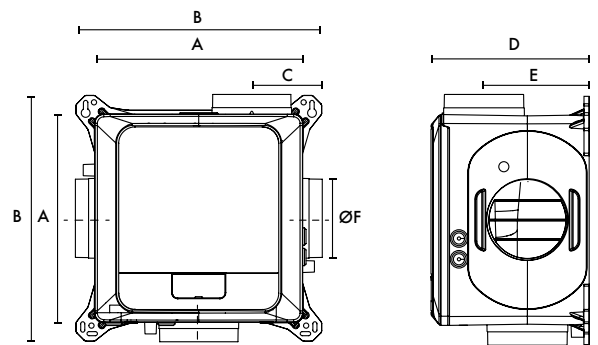

MVDC-MSH Uniflex

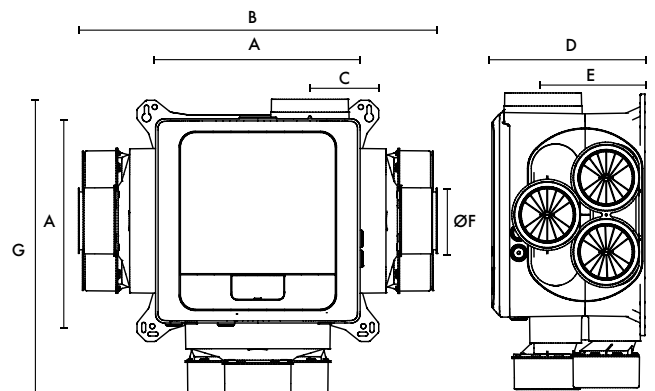

Model	A	B	C	D	E	ØF	G	kg	No. Extract Spigots
MVDC-MS/H	330	391	111	248	165	125	-	4.1	3
MVDC-MSH Uniflex	330	567	111	248	165	90	479	7	9

Performance Guide

MVDC-MSH features an integral humidistat which triggers the unit to boost when humidity levels in the duct system exceed 70%.

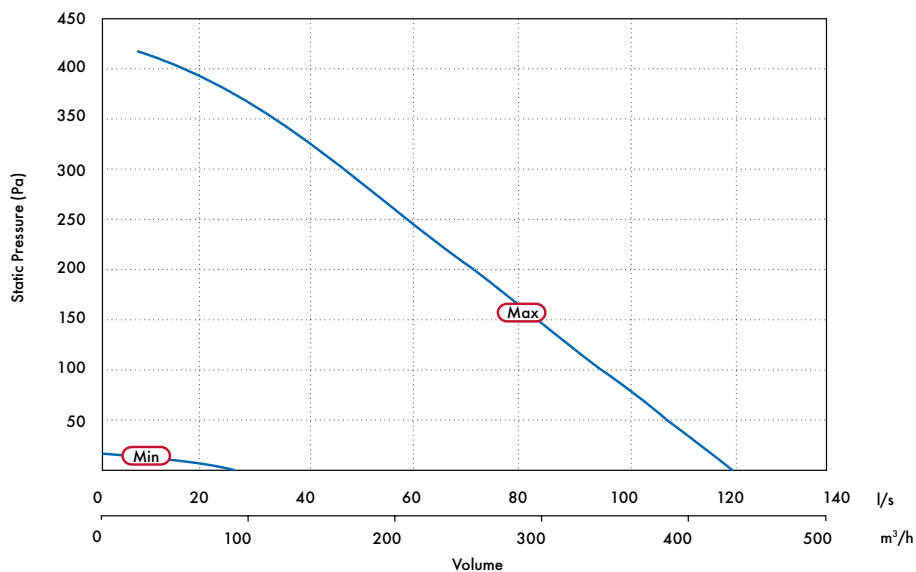

Min				Max				
Casing Breakout dB(A) @ 3m	Inlet Duct dB(A)	FID l/s	Power Watts	Casing Breakout dB(A) @ 3m	Inlet Duct dB(A)	FID l/s	Power Watts	SEC Class (inc. LDC)
13	18	24	2	37	40	118	44	B
13	18	24	2	37	40	118	44	B

Sound Data

Speed	Test Mode	Octave Band (Hz) Sound Power Levels, dB								LwA	SpL @ 3m
		63	125	250	500	1k	2k	4k	8k		
20%	Extract	50.3	40.4	40.0	33.7	28.1	21.6	18.0	23.0	36.2	18.7
	Breakout	40.2	38.7	32.8	26.9	17.1	14.5	17.8	22.4	29.9	9.4
40%	Extract	58.4	52.9	52.4	46.2	41.5	30.4	20.8	23.1	48.2	30.7
	Breakout	42.7	44.7	45.3	33.0	24.3	19.7	17.9	22.4	37.5	17.0
60%	Extract	56.4	58.2	62.5	53.9	41.3	40.0	32.0	25.9	56.2	38.7
	Breakout	40.1	52.1	50.2	39.2	30.6	32.2	20.0	22.4	43.9	23.4
80%	Extract	60.1	63.9	67.2	63.8	48.4	46.2	41.6	35.0	63.1	45.6
	Breakout	33.6	60.1	47.4	49.6	36.1	32.7	24.2	22.7	49.2	28.7
100%	Extract	76.2	79.3	71.9	69.7	53.6	51.4	47.9	42.2	69.7	52.2
	Breakout	47.3	56.6	52.5	52.7	40.7	37.7	29.7	23.7	51.7	31.2

Lo-Carbon NBR dMEV/dMEVe

- Market leading efficiency
- Digital controls with display
- Fully adjustable trickle & boost airflow settings
- 100mm & 125mm model
- Recognised in SAP PCDB
- Constant volume
- Display showing airflow and system pressure
- Switched live connection for external switches/sensors
- IPX5 rated
- Multi-orientation grille
- NHBC Approved
- STAS Approved (Scotland)
- Airflow sensor models UKAS calibrated



Lo-Carbon NBR dMEV

Continuous running, constant volume dMEV range with switched live (LS) and innovative digital display and harmonised control platform. Quiet running and with high pressure development, the dMEV is best in class.

The unique patented display provides the calibrated installed airflow and pressure meaning that there is no need to test the installation with an airflow measuring device.

The constant volume technology automatically adjusts the speed of the fan to ensure the desired airflow is delivered. A silent high pressure axial impeller means Lo-Carbon dMEV can meet the requirements of many domestic installations without the need to use a traditional centrifugal fan.

A brand new control platform also provides fully adjustable airflow in 1l/s increments, meaning wholehouse rates can be achieved easily using fewer fans than is currently possible with any other dMEV product on the market.

Longer Duct Runs

A new 125mm dMEV fan is also available to further improve Dwelling Emission Rates (DER) by improving efficiency and lowering noise. The larger 125mm spigot also means there are almost no restrictions in terms of duct lengths and bends used in the system, when compared to a traditional 100mm axial fan. This means fewer fans are required to achieve wholehouse ventilation rates.

As can be seen below, an axial dMEV fan consumes a fraction of the energy of the equivalent centrifugal fan - drastically reducing DER.

Configuration	Location	Alternative Centrifugal Fan SFP	Vent-Axia dMEV 125mm SFP
In room	Kitchen	0.38	0.16
	Wet Room	0.29	0.20
Through Wall	Kitchen	0.36	0.12
	Wet Room	0.28	0.16

Side View of Airflow Display

Be confident that the dMEV is delivering the right performance with our innovative digital display showing the airflow and system pressure of the installed product.



Comfort Control Option

Designed to offer a more relaxing environment to the homeowner, the Lo-Carbon dMEV features a delayed start option. This patented comfort control option is selectable at installation and allows the homeowner to enjoy a quiet, peaceful bathroom for up to 20 minutes before the Boost activates. Furthermore, if the light switch turns On and Off within 3 minutes, the Boost will not activate. No more disturbing the family if the bathroom light is turned on during the night.

Model

Lo-Carbon NBR dMEVe & dMEVe HT

For kitchen, utility and bathroom/toilet applications, the continuous running H model incorporates an adjustable (40% - 90%) ambient response humidistat. The fan will increase the extract rate if the humidity rises above the point set at installation.

Fixed Speed Settings (3 boost speeds, 2 trickle speeds)

Model	Stock Ref
100e (Switch Live)	474496
100e HT (Humidity Control)	474497

Fixed Speed Settings (2 boost speeds, 3 trickle speeds)

Model	Stock Ref
125e (Switch Live)	495364
125e HT (Humidity Control)	495365

Lo-Carbon NBR dMEV & dMEV HT

Continuous running dMEV available in two sizes. Humidity control models incorporate an adjustable (40% - 90%) ambient response humidistat. The fan will increase the extract rate if the humidity rises above the point set at installation. Variable speed options for trickle and boost, dependant on size for maximum control. Features a display prism, to allow users to see airflow being achieved without having to remove a grille.

Variable Speed Settings (5-30 l/s trickle, 6-35 l/s boost)

Model	Stock Ref
100 (Switch Live)	475142
100 HT (Humidity Control)	473809

Variable Speed Settings (9-30 l/s trickle, 10-35 l/s boost)

Model	Stock Ref
125 (Switch Live)	494147
125 HT (Humidity Control)	494148

Accessories

Model	Stock Ref
Wall Kit White 100mm	254102
Wall Kit Brown 100mm	254100
Ceiling Kit 100mm	407928
Window Kit 100mm	407927
Decoration Frame 100mm	474041
Wall Kit White 125mm	455226
Conversion Kit 150mm	408680

Consultant Specification

The de-centralised mechanical extract ventilation unit shall be the NBR DMEV as manufactured by Vent-Axia, exact unit sizing and specification shall be in accordance with the particular specification.

The range should consist of IPX5 rated 100mm and 125mm sizes to meet the Building Regulations compliant design, extracting air from wet rooms (including kitchen and utility) via rigid, flexible ducting or through-wall applications with the fewest fans possible, supplied with a 7 year warranty.

The 100mm DMEV should have variable speed settings of 5-30 l/s on trickle and 6-35 l/s on boost, achieving a minimum noise level of 13 dB(A) at 3 metres. The 125mm DMEV should have variable speed settings of 9-30 l/s on trickle and 10-35 l/s on boost, achieving a minimum noise level of 12.9 dB(A) at 3 metres. All units shall be and independently 3rd party tested at the Sound Research Laboratory (SRL), tested to BS EN 13141-6.

The unit shall comprise a single high efficiency EC/DC motor to deliver specific fan powers as low as 0.12 w/l/s, as measured in accordance with the SAP PCDB test method and listed on the PCDB database.

The controls for the DMEV unit shall provide fully adjustable, continuous trickle and boost speeds, with the airflow being controlled in 1 l/s increments. The boost speed shall be activated via a switch live input or integral humidistat.

The unit shall include an integral humidity sensor with ambient and rapid response capability, which increases fan speed in proportion to the level of humidity detected. The unit shall also automatically raise the humidity threshold set point as temperature decreases in order to prevent unnecessary boosting due to background humidity levels.

The unit shall be able to be commissioned as a continuous running or intermittent fan according to the Building Regulations compliant design. The fan will have an in-built spirit level for ease of installation.

Commissioning of the fan in accordance with the Building regulations shall be achieved without the use of an airflow measuring device. The fan shall be provided with a UKAS calibrated, constant volume function with the flow rates displayed on the unit without having to remove the cover via the display prism.

Dimensions (mm)

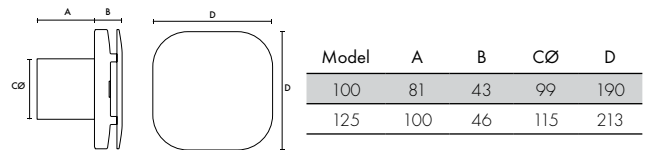

Performance Guide

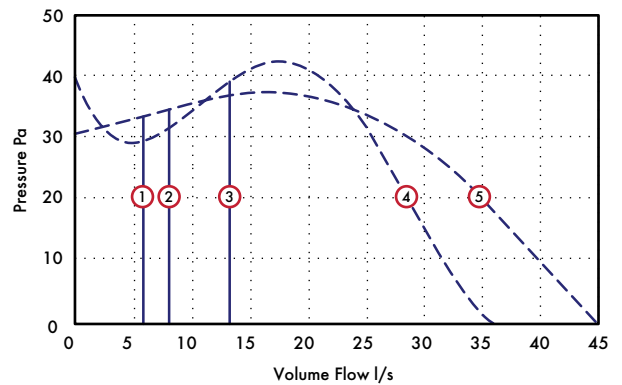

- ① 6l/s Constant Volume
- ② 8l/s Constant Volume
- ③ 13l/s Constant Volume
- ④ Maximum pressure available to deliver airflow - 100mm model
- ⑤ Maximum pressure available to deliver airflow - 125mm model

Sound

100mm					125mm						
Flow l/s	Min	6	8	13	Max	Flow l/s	Min	9	13	15	Max
Pa	-	5	7	17	-	Pa	-	4	7	9	-
dB(A)	13	14	17	24	41	dB(A)	12	14	17	19	36

SAP PCDB Performance

Unit Configuration	Location	100 Model	125 Model
In room (rigid duct)	Kitchen	0.17	0.16
	Wet room	0.17	0.20
In room (flex-duct)	Kitchen	0.16	0.15
	Wet room	0.16	0.20
Through wall	Kitchen	0.12	0.12
	Wet room	0.14	0.16

Lo-Carbon PoziDry Pro™

- Anti-vibration joist mounting legs as standard
- Fully adjustable between 19l/s - 49l/s
- Smart Sense™ Technology offers simple control and data logging
- Uses latest Lo-Carbon motor technology for low running costs
- Ultra low sound level
- Complete with ceiling diffuser, flexible duct and G4 filters with F7 upgrade option
- IPX2 rated
- BBA Approved



Some parts of this product are made using recycled material therefore the colour of the plastic may vary from white to black. To find out more please visit www.vent-axia.com/sustainable

Positive Input Ventilation

Designed to prevent and treat condensation and mould quickly. The BBA approved PoziDry Pro™ is the perfect solution for general refurbishment, as its discreet, easy to install and almost silent running.

Lo-Carbon PoziDry Pro™ offers a quick and simple solution. A loft mounted positive input fan draws fresh air from the loft, filters it and gently feeds it into the dwelling via a ceiling mounted diffuser. Clean, fresh filtered air with a lower moisture content dilutes, displaces and replaces, contaminated and moisture laden air.

Installation

The Lo-Carbon PoziDry Pro™ is uniquely flexible in its installation methods, high sided anti-vibration legs and a hanging kit both come as standard, allowing the PoziDry Pro™ to be installed quickly in any sized loft. The easy carry handle incorporated into the body makes carrying the unit easy and safe; especially useful when lifting the unit through loft hatches.

The unit is supplied with a purpose designed diffuser to be located over the stairwell of a conventional dwelling, in the main hall of a bungalow, in the landing or hallway. The 4-point contact easy fit technology allows fast and repeatable 'drill free' installation.

Using Smart Sense™ Technology the unit is easily set to the appropriate speed at installation based on the size of the dwelling. Natural leakage points that are present in all dwellings, as well as purpose provided exhaust points enhances the air change. En-suites and utility areas should be serviced by continuous mechanical extract ventilation.

The PoziDry Pro™ can also be set to 'Radon' mode in properties that are affected by high radon gas levels. The unit will run continuously to ensure the constant supply of good indoor air to protect residents from harmful gases.

Performance

With a lightweight construction, the Lo-Carbon PoziDry Pro™ features a specially developed Lo-Carbon DC fan/motor arrangement which runs quietly and delivers incredibly low running costs. The Lo-Carbon PoziDry Pro™ uses a sensor to monitor the temperature in the loft, automatically adjusting the air volume when necessary. Additionally, resident comfort can be assured through an option to change the temperature at which the unit increases or decreases airflow. The unit will continuously ventilate silently in the background whilst in 'Trickle' mode. Once the unit automatically senses excess heat being lost into the loft the airflow will increase to 'Energy Recovery' mode to recover heat that would otherwise be lost through the roof. During summer months should the loft exceed 27°C (adjustable) the unit will enter 'Stand-by' mode in order stop the circulation of warm air allowing for a more comfortable living environment. PoziDry Pro™ Heater models automatically turn on the 500W heater to help take the chill off the incoming air.

Filter

Standard filters supplied with the PoziDry Pro™ are G4 (PM10 filtration) which filter out many every day pollutants such as pollen and dust. Optional F7 filters are available (PM2.5 filtration) removing tobacco smoke, diesel particulates, spores and a number of bacteria.

Data Logger

Smart Sense™ Technology allows the unit to record how long it has been running in each of its speeds. It also measures the number of days the product has been switched on to provide precise running information. Smart Sense™ Technology can also record the duration of heater activity and energy used.

Speed Control

Smart Sense™ Technology makes speed selection easy. Once house size is selected based on number of bedrooms, PoziDry Pro™ automatically selects the correct 'Trickle' and 'Energy Recovery' speeds. Should you need to adjust speed manually this can be done easily. The Smart Sense™ interface can also be locked ensuring that settings are not tampered with.

Heater

The heater model comes with a 500W heater attached to the unit. Smart Sense™ controls allow the PoziDry Pro™ to be adjusted fully when the heater is activated making it adaptable for all lifestyles.

Air Replacement Grille Set*

This set is for air replacement through doors. Consists of a two-piece telescopic set, which fits unobtrusively on either side of the door panel. Minimum fixing thickness 30mm. Plastic. Dimensions: 454 x 90mm.

*Only required if there is not a 10mm undercut on the internal doors.

Mounting Options

PoziDry Pro™ comes as standard with both high sided anti-vibration legs and a hanging kit. The legs are designed to mount between standard joist widths between 300-650mm. Clip and fit connections allow for easy installation.

Motor

The electronically controlled DC motor is manufactured with long life ball bearings and is fitted with Standard Thermal Overload Protection (S.T.O.P.). Suitable for ambient operating temperatures of -25°C to +40°C. For complete peace of mind, the Vent-Axia Lo-Carbon PoziDry Pro™ is backed by a 5 year warranty.

Discreet Diffuser

The discreet circular diffuser** is easily installed, fitted and maintained. Easy fix features it can be installed against uneven ceiling surfaces with no gaps. Its low profile and aesthetically pleasing design has been developed with tenant acceptability in mind. The Smart Air™ Technology reduces air supply noise while increasing performance by 10%. The easy clip blanking plates help to control airflow into the property.

**Diffuser will always be supplied using white plastic.

Models

Dimensions (mm)

A*	B	C	D	ØE	F	G	ØH	I**
300-650	425	365	330	200	530-570	300	220	400-600

*Variable to adapt to differing joist widths. ** Variable to allow for adapting product height

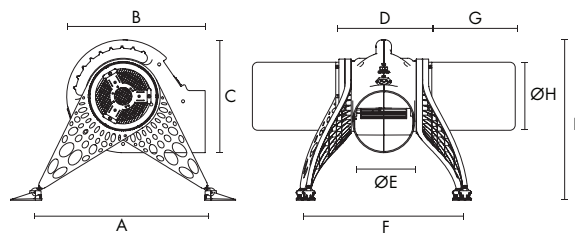

Performance Guide

Bedroom	Trickle		Energy Recovery	
	Flow Rate (l/s)	Power (W)	Flow Rate (l/s)	Power (W)
1	19	3.1	29	5.1
2	25	4.3	37	7.6
3	31	6.0	46	12.0
4	37	8.0	49	13.1
Adjustable	19-48	-	20-49	-

All models come with G4 filter, 2m of flexi duct and Ø200mm Diffuser. The Pozi Dry Pro™ FD model diffuser is fire rated but does not include Smart Air™ Technology.

PoziDry Pro™

Stock Ref

476310

PoziDry Pro™ with Heater

Stock Ref

476311

PoziDry Pro FD with Heater (Multi-storey Compliant)

Stock Ref

476312

Accessories

Model

Stock Ref

Twin Spigot Kit

449071

An additional kit to allow an extra circular diffuser to be installed near the PoziDry unit. The kit includes 1 x Ø200mm 6m Duct, 2 x Worm Clips, 1 x Ø200mm Equal Y Piece and 1 x Diffuser.

Diffuser

478228

F7 Filter Set

477957

G4 Filter Set

477629

Air replacement grille set - Brown

561400

Air replacement grille set - Ivory

561401

Lo-Carbon PoziDry Compact Pro

- Ultra small unit can fit in the smallest of spaces
- Removable inner cartridge for easy repairs and maintenance
- Flow rates adjustable in 1l/s increments, up to 30l/s
- Extremely low energy consumption
- Washable, high capacity G4 or F7 filter
- Advanced data logger and 3 digit settings lock for peace of mind
- 7 year warranty
- Ideal solution for flats with mould in a habitable room
- BBA Approved



Positive Input Ventilation

For those properties that do not have a loft, the Lo-Carbon PoziDry Compact Pro provides an easy to install solution. The unit has been designed to be as small as possible with multiple inlet and outlet positions allowing it to be installed in the best place every time.

Air is drawn into the Lo-Carbon PoziDry Compact Pro unit via an external inlet and through a short length of duct. The specially developed power pack cartridge assembly draws the air through an integral, high capacity, washable filter. The precision engineered scroll/impeller assembly and anti-vibration EPP body guarantees ultra low sound levels and increased energy efficiency.

The fresh, filtered airflow passes along the ducting and enters the room through a discreet grille. The rotatable integrated grille can be turned to one of 8 positions ensuring that the airflow is always directed upwards, reducing cold draughts.

The system provides fresh, tempered air into the home and creates an indoor environment where the damaging effects of condensation find it hard to exist, benefiting both the occupants and the structure of the building.

Performance

If the ambient temperature exceeds 27°C, the Lo-Carbon PoziDry Compact Pro will automatically switch off to prevent over-heating. This temperature threshold can be adjusted at installation.

In the case of the integral 300W heater version, the heater element is automatically activated when necessary and tempers the supply air to a chosen temperature.

Peace of Mind

Smart Sense™ technology records usage, energy consumption and filter life to ensure the unit has been used as intended. This is secured by an installer enabled 3 digit settings lock to make the PoziDry Compact Pro tamper free.

Model

With integral heater
Stock Ref
479188

Accessories

Model	Stock Ref
ABS Spare Cover	479843
Spare Boxing Cover	479849
Spare Boxing Cover with Grille right	479850
Spare Boxing Cover with Grille left	479851
Boxing 200mm x 200mm x 2m	479852
Boxing End Stop	479853
Boxing End Stop with Grille	479854
Boxing Inner Bend	479855
Boxing Outer Bend	479856
Silencer Kit	479857
Acoustic Flexi Duct	443273
Spare Scroll Cartridge	479859
Spare PM10 Filter	479860
Spare PM2.5 filter	479861

Dimensions (mm)

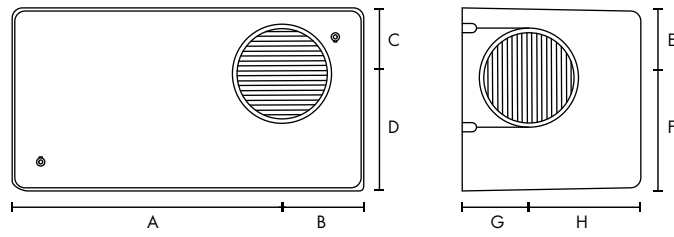

A	B	C	D	E	F	G	H	Spigot Ø	Unit Weight
302	91	74	132	79	127	75	125	100	3kg

Performance Guide

Speed	FID (l/s)	Power (W)*	No. Bedrooms	Breakout dB(A) @ 3m*
1	13	3.5	1	11.6
2	17	6.0	2	13.6
3	21	9.0	3	17.2

* Sound data is measured as breakout @ 3m assuming inlet and outlet is ducted.

Residential & Commercial dMVHR

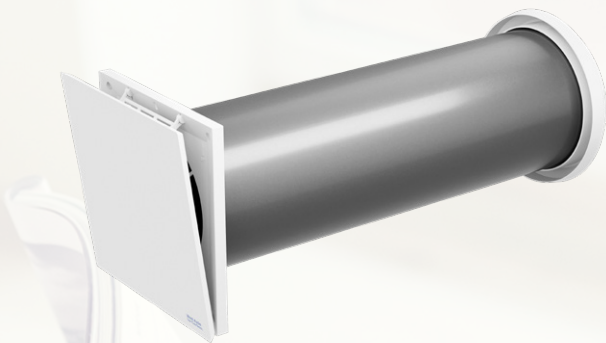

Improving air quality on a room-by-room basis, the Vent-Axia through-the-wall mounted range of heat recovery ventilation units simultaneously extract stale air and introduce fresh air - warming the incoming airflow with heat recovered from the exhaust stream.

Vent-Axia Lo-Carbon Heat Save

A reversible fan which extracts dirty air from the room and replace it with outside air 70 seconds later. This air passes through a filter to ensure that clean air enters the room. These systems work best in pairs as when one unit is extracting, the other can be supplying air to provide a balanced ventilation system. They are controlled by a SENWZP Sentinel wired zone controller which can operate up to 8 units in synchronization. This provides a single room or whole house balanced ventilation system with heat recovery.

As well as filtering the air, the Vent-Axia Lo-Carbon Heat Save uses a thermal accumulator to extract warmth from the outgoing air and uses it to temper the incoming air to avoid the feeling of cold drafts and recover heat that would otherwise be lost to the outside.

Vent-Axia[®]

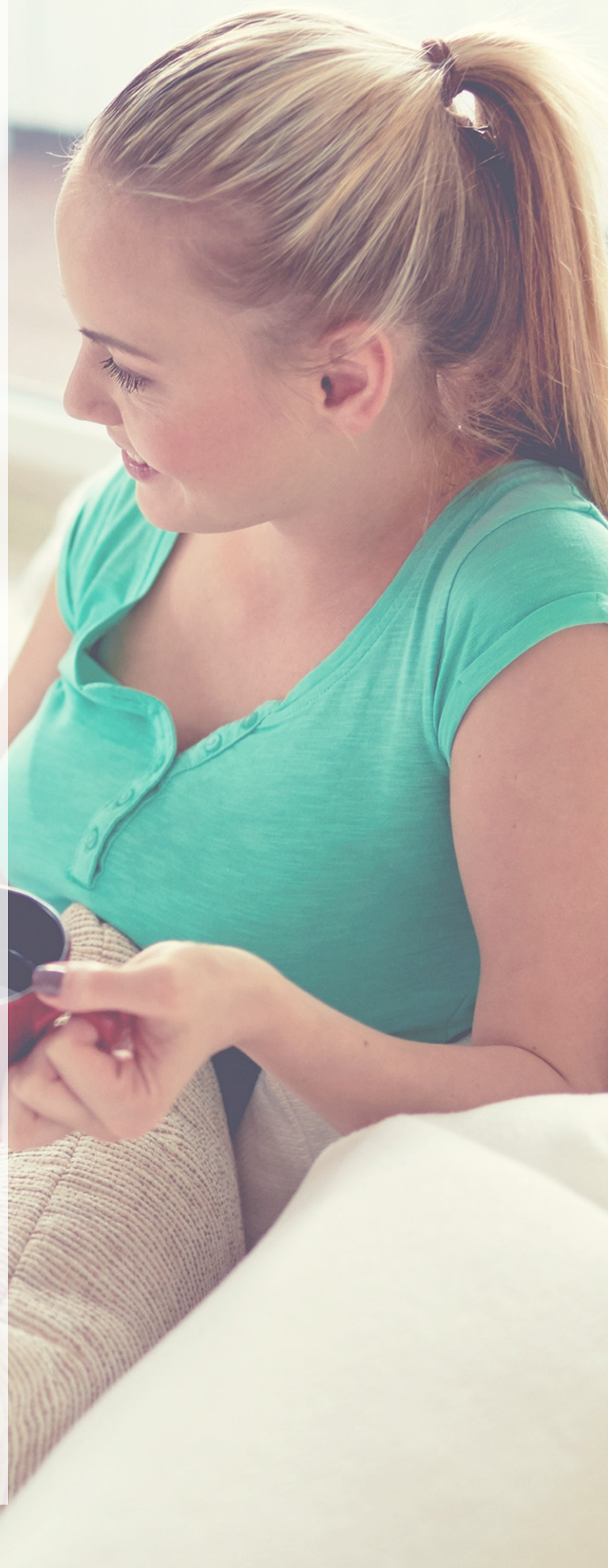



NEW Lo-Carbon Calido

E:3-E:4

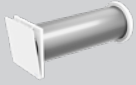

Lo-Carbon Heat Save/Alternate Flow Heat Recovery

E:5-E:6



Lo-Carbon Tempra/SELV

E:7-E:8



HR200WK/WJ

E:9-E:10



HR300

E:11-E:12

NEW Vent-Axia Lo-Carbon Calido

- Up to 80% heat recovery to reduce energy bills
- Reduce the home's carbon footprint and save money on energy bills
- Ideal for retrofit applications
- Intelligent controls to eliminate condensation within the unit
- Adjustable airflows
- Filter replacement indicator ensures continuous good indoor air quality
- Incredibly reliable due to EC motor
- CE and S Mark - independently tested and certified for safety
- IP24 rated
- 5 year warranty



Discrete Whole House Heat Recovery

The Vent-Axia Lo-Carbon Calido is designed to remove stale air from any habitable room and replace it with fresh air. This unit is designed to be ducted therefore it can benefit more than one room at a time i.e. if installed in a bathroom, stale and moist air will be extracted and fresh air will be supplied to other habitable rooms via installed ducting.

The Vent-Axia Lo-Carbon Calido offers up to 80% heat recovery which helps reduce the amount of heat lost from the property. This helps save money by reducing energy costs as well as reducing carbon emissions. The unit cleverly recovers heat from heat lost through extraction and reuses it to warm the air re-entering the property.

One unit can help improve the air quality of a whole house and with changeable filters it can help provide clean air all year round. With three air flow options available, the Vent-Axia Lo-Carbon Calido can be installed in many types of properties and its compact design means it will ventilate and recover heat quietly in the background. It can also be wall or ceiling mounted depending on space availability, making it perfect for many retrofit applications.

Models

Vent-Axia Lo-Carbon Calido

The Vent-Axia Lo-Carbon Calido is a robust unit with an IP24 rating and is double insulated for extra protection. It uses an EC motor, which is incredibly reliable and comes with a five year warranty.

Stock Ref
411133

Accessories

Model

Filter kit standard G4 2pcs

External wall kit 100mm

Exhaust air adaptor

Calido Controller

Stock Ref

411156

411163

411164

411331

Typical Installation

The Vent-Axia Lo-Carbon Calido requires two 100mm diameter holes - one to extract stale air and one to intake fresh air. It also comes with a drilling template for an easy install.

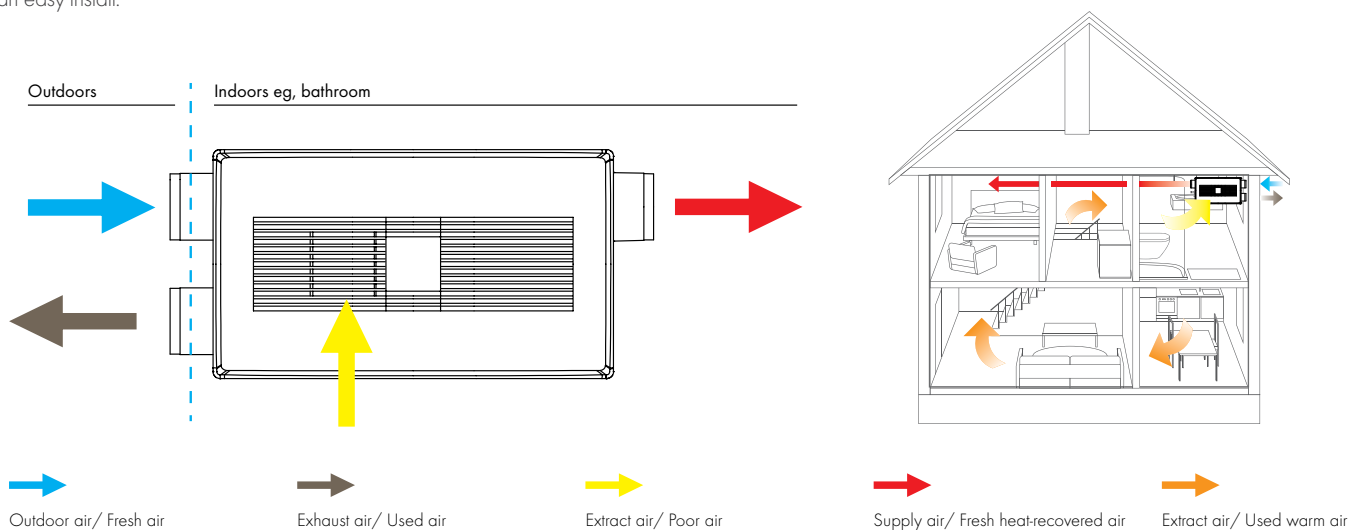

Dimensions (mm)

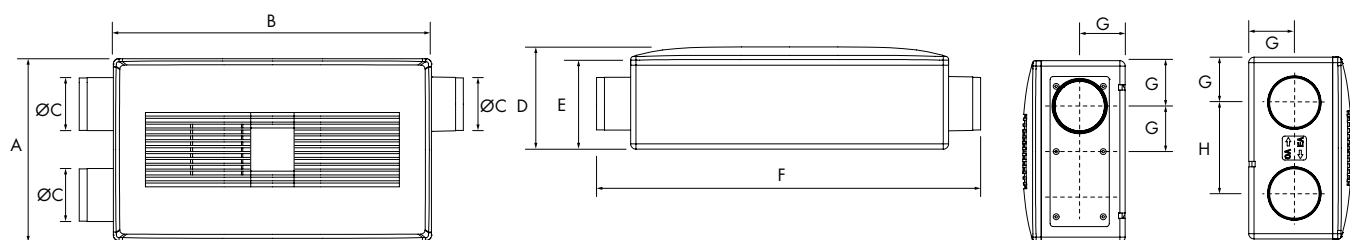

A	B	ØC	D	E	F	G	H
340	595	100	191	167	720	85	170

Performance

Wall opening:	100 mm
Balanced Air flow:	8.3 - 25 l/s
Power consumption:	3.5 - 25W
Sound emission:	19 - 35 dB(A)
Heat Recovery:	80%
Temperature range:	-30 - 35 °C

Vent-Axia Lo-Carbon Heat Save

- Suitable for improving indoor air quality in habitable rooms
- Fully customisable ventilation via a control panel
- Easy to install, no need for ducting, wall sleeve included
- Easily maintained with cleanable filter and ceramic heat exchanger
- 5 year warranty for peace of mind
- Up to 84% heat recovery to reduce energy bills
- Anti-frost protection built in
- Replace extracted air with filtered air
- Reduce the home's carbon footprint and save money on energy bills

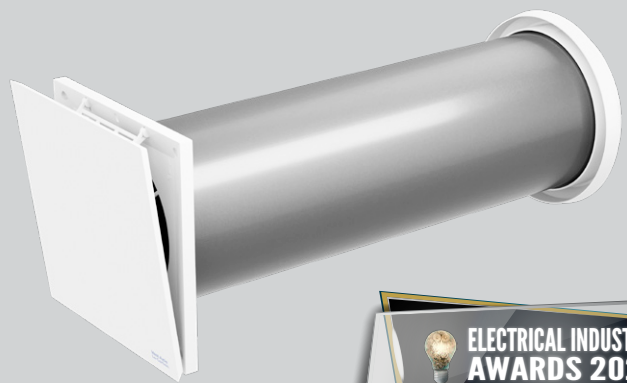

Through-The-Wall Heat Recovery Unit

The Vent-Axia Lo-Carbon Heat Save is a ventilation unit designed for living rooms and bedrooms in single and multi-family buildings. The unit is usually located in an exterior wall to provide new air to the room.

The Vent-Axia Lo-Carbon Heat Save uses a reversible fan to extract dirty air from the room and replace it with outside air 70 seconds later. This air passes through a filter to ensure that clean air enters the room. These systems work best in pairs as when one unit is extracting, the other can be supplying air to provide a balanced ventilation system. They are controlled by a SENWZP Sentinel wired zone controller which can operate up to 8 units in synchronization. This provides a single room or whole house balanced ventilation system with heat recovery.

As well as filtering the air, the Vent-Axia Lo-Carbon Heat Save uses a thermal accumulator to extract warmth from the outgoing air and uses it to temper the incoming air to avoid the feeling of cold drafts and recover heat that would otherwise be lost to the outside.

Models

Vent-Axia Lo-Carbon Heat Save

Decentralised ventilation system with up to 84% heat recovery. Compact design for apartments or houses with 180mm diameter, ideal for refurbishment. Includes reversible fan with a thermal accumulator, external wall grille, wall sleeve, dust filter. Requires 1x SENWZP (496037) wired zone controller per installation of 8 units.

Stock Ref
496036

Accessories

Model

Sentinel Wired Zone Control Panel (SENWZP)	Stock Ref
Spare Inner Cover 220x220	496037
Heat Save PM10 ISO Coarse 60% (formerly G4) filter	496108
External Wall Sleeve 160x745	496038
Spare Wall Sleeve 160x495	495328
Spare Reversible Fan	496105
Spare Thermal Accumulator	496110
Spare Weather Protection Grille	496111
Sound Absorbing Insert	496107
	496109

Typical Installation

The Vent-Axia Lo-Carbon Heat Save can be fitted in a 167mm - 180mm diameter hole. Maximum wall thickness is 460mm or 745mm with optional wall tube (see accessories). The wall sleeve length (included up to 460mm) can be cut down to size to fit any wall thickness.

Vent-Axia Lo-Carbon Heat Save units work best in pairs. When one unit is extracting, the other can be supplying air to provide a balanced ventilation system. They alternate direction every 70 seconds when the thermal accumulator on the extract unit has warmed up allowing the supply air to benefit from these thermal gains. They are controlled by a SENWZP Sentinel wired zone controller. This is fully modular and controllable with customised ventilation profiles available so that every room in the home can have the perfect ventilation.

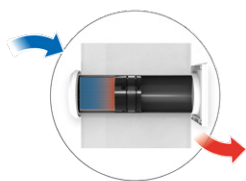

Supply Mode

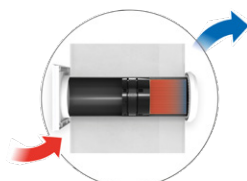

Extract Mode

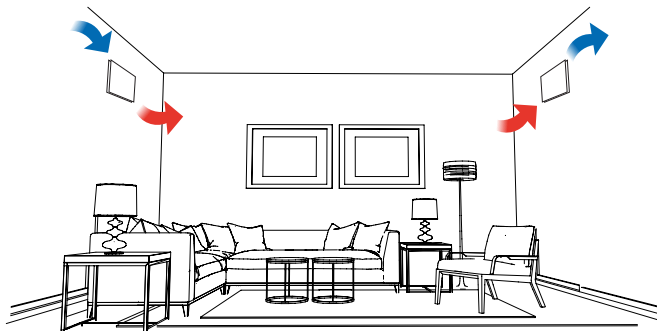

Dimensions (mm)

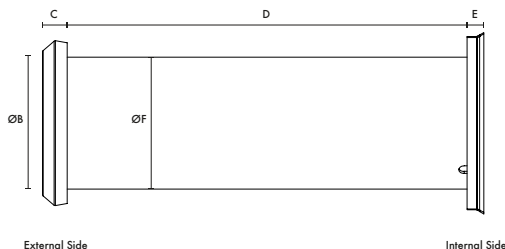
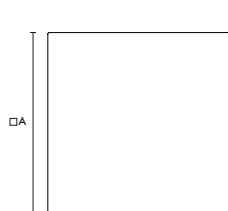

External Side

Internal Side

□A	∅B	C	D	E	∅F
220	200	30	485	20	160

Performance

Wall opening:	167 - 180 mm
Wall thickness with plaster/render:	>290 mm
Supply Air flow:	2.8 - 12.0 l/s
Extract Air flow:	2.8 - 12.0 l/s
Average Air flow:	1.4 - 6.0 l/s
Power consumption:	1 - 3W
Sound emission:	18 - 36 dB(A)
Heat Recovery:	84%
Temperature range:	-20 - 50 °C

Lo-Carbon Tempra/SELV

- Fits in 100mm diameter hole - ideal for refurbishments
- Up to 78% heat recovery
- Available in 2 wall depths: 320mm and 460mm
- Reduces the home's carbon footprint
- IPX4 rated
- Summer setting (extract only)
- Helps prevent noise ingress
- Continuous running or intermittent extract
- Meets current Building Regulations Approved Documents F and L
- Low power consumption - only 3.2 W



Through-The-Wall Heat Recovery Unit

The Vent-Axia Lo-Carbon Tempra is designed to fit in 100mm diameter hole and is suitable for refurbished properties in kitchens, bathrooms, toilets or utility rooms. The unit meets the performance requirements for continuous extract fans under the current Building Regulations Approved Document F.

The Tempra is available in three models, a P version with pullcord control, a T version with overrun timer and an HTP version with built-in pullcord, overrun timer and humidistat. Two spigot lengths are available; 320mm and 460mm.

The manual summer setting allows the unit to be set to extract only, helping to prevent a dwelling becoming too warm in hot summer conditions.

Performance

The Tempra can be set to run continuously at 6 l/s or 9 l/s, boosting up to 15 l/s, recovering heat from extracted air and returning it to the dwelling. The unique, compact heat exchanger has a temperature efficiency up to 78%, saving energy and reducing your carbon footprint. For intermittent extract the Tempra is set to 15 l/s.

Tempra is also designed so that the replacement air being introduced is at a reduced rate ensuring that the room being ventilated is still under a slight negative pressure. This ensures that fresh air is brought into the room from the rest of the house preventing humid air migrating.

The Lo-Carbon EC/DC motor with twin impellers consumes as little as 3.2 Watts on trickle rate and runs almost silently at only 20dB(A).

Typical Installation

The unique heat exchanger design allows the Tempra to be fitted in a 100mm diameter hole, allowing it to replace standard 100mm extract fans while giving all the benefits of heat recovery. Maximum wall thickness is 460mm.

A longer version of the Tempra is available, designed for installations where the wall thickness is between 321mm and 460mm. 460mm models are identified by an 'L'.

Models

Lo-Carbon Tempra P (Pullcord)

Constant trickle speed with pullcord to boost or intermittent operation by pullcord.

Model	Stock Ref
320mm P	443312
320mm SELV P	444368
460mm LP	403832
460mm SELV LP	403833

Lo-Carbon Tempra T (Timer)

Constant trickle speed with switch live to boost or intermittent operation by switch live.

Model	Stock Ref
320mm T	443310
320mm SELV T	444369
460mm SELV LT	403835

Lo-Carbon Tempra HTP (Humidistat/Timer/Pullcord)

Constant trickle speed with humidistat and linked overrun timer to boost or intermittent operation by switch live.

Model	Stock Ref
320mm HTP	443311
320mm SELV HTP	444370
460mm LHTP	403836
460mm SELV LHTP	403837

Accessories

100mm High Rise Kit

320mm white duct with black seal.

Model	Stock Ref
100mm High Rise Kit	449011

Wall Kit

Extendable Wall Tube suitable for both spigot lengths.

Model	Stock Ref
Wall kit	445529

150mm Conversion Kit
 For replacement of 150 diameter fan.
 Stock Ref
403847

Dimensions (mm)

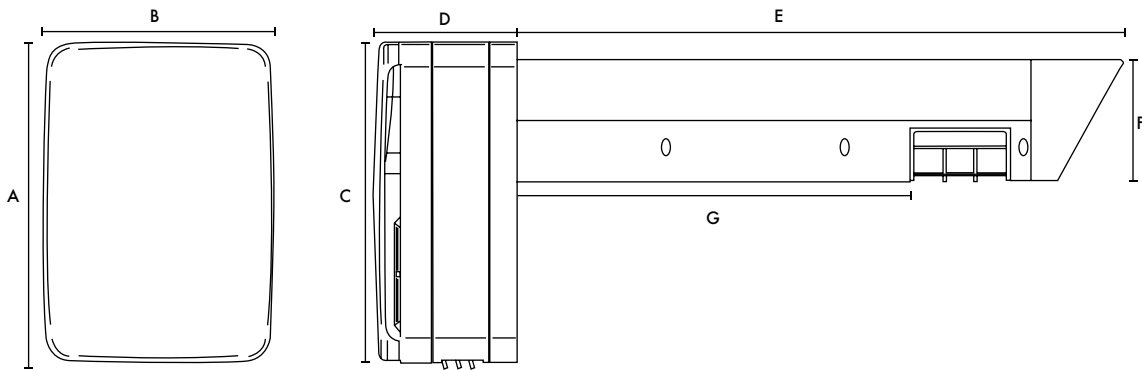

	A	B	C	D	E	F	G
Standard	266	190	262	117	496	99	321
Long	266	190	262	117	636	99	461

Performance

Model	Extract Performance l/s			Power Consumption Watts			Sound @dB(A)*		
	Trickle Low	Trickle High	Boost	Trickle Low	Trickle High	Boost	Trickle Low	Trickle High	Boost
Lo-Carbon Tempra (All Models)	6	9	15	3.2	5.7	26.6	20	22	36

*Octave band frequency range of 250Hz to 4KHz at 3m. Unit mounted on a reflective surface.

Heat Exchange - what is heat recovery?

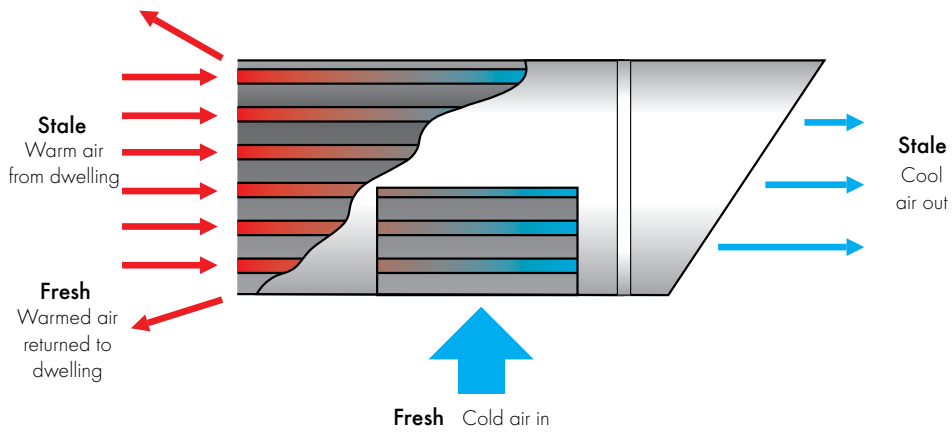

HR200WK/WJ

- Single room domestic heat recovery ventilation unit
- 3 speed motor
- Integral washable filter
- Up to 75% heat recovery
- Saves energy - controls condensation
- Low noise



Heat Recovery Ventilation

HR200WK

The Vent-Axia HR200WK is a heat recovery ventilation unit specifically designed for use in domestic kitchens and utility rooms to meet the Building Regulations. The unit is also suitable for light commercial applications up to 61l/s (220m³/h).

HR200WJ

Developed for lower flows and lower noise, the HR200WJ is ideal for single living accommodation, for example student accommodation or care homes.

The three speed, external rotor motor has two matched impellers to ensure a controlled airflow through the unit, with exceptionally economical 25 Watt low speed power consumption.

The compact, self-contained unit is designed for through-the-wall mounting.

Easy Installation

The units fit through walls up to 335mm thick requiring a fixing hole 250mm square. The internal grille has washable, polymeric foam supply and extract filters. Only the neat internal twin grille is visible from the room. A wall extension sleeve is available for walls up to 550mm thick.

Heat Exchanger

The highly efficient, polymeric heat exchanger cube is washable. The compact cube interleaves outgoing moist warm air with incoming fresh air and allows the heat from one to warm the other without the two air streams mixing. Up to 75% of the heat, which would otherwise be lost, is transferred to the intake air, ensuring energy saving ventilation.

Electrical

HR200WK/WJ 220-240V/1/50Hz Class 1 earthed appliance. The 3 speed motor, can be wired to operate On/Off for any one of the three speeds. Alternatively, an Ambient Response Humidity Sensor or simple

changeover switch can be used to provide switching between any two speeds, giving permanent trickle ventilation and automatic changeover to a higher speed during periods of high moisture generation. Also the 3 speed controller enables the unit to be switched from permanent trickle to either medium or boost speed.

Models

HR200WK

A heat recovery unit specifically designed for use in domestic kitchens and utility rooms to meet the latest Building Regulations. Main body colour; Dark Brown.

Stock Ref

14120020

HR200WJ

Lower air-flows mean this unit is ideally suitable for residential applications such as care homes and student accommodation. Main body colour; Dark Grey. 3 speed motor, trickle ventilation mode, optional range of switches available.

Stock Ref

479118

Accessories

Model	Stock Ref
Extension Wall Sleeve	370421
Electronic Controller	W300310

Controllers

HR200WK Controller

A three position rotary control which enables the unit to be switched from permanent trickle ventilation to either medium or boost speed.

Model	Stock Ref
HR200WK Controller	563533

SEC Class

Model	SEC Class	SEC Class (inc. LDC)
HR200WK	C	A
HR200WJ	C	A

Dimensions (mm)

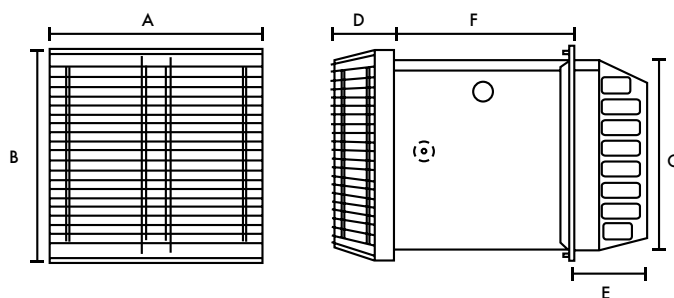

Wall fixing hole 250mm x 250mm sq.

A	B	C	D	E	F
270	270	245	85	68min	335max

Weight 9.7kg

Performance

Model		Performance l/s (m ³ /h)			% Heat Recovery	Sound dB(A) @ 3m
		Extract	Intake	Watts		
HR200WK	Speed 1	16 (60)	13 (50)	25	75	19
	Speed 2	30 (110)	27 (100)	60	70	33
	Speed 3	61 (220)	55 (200)	140	65	46
HR200WJ	Speed 1	8 (28)	5 (19)	9	75	18
	Speed 2	14 (52)	9 (34)	18	75	18
	Speed 3	28 (100)	18 (64)	51	70	31

HR300

- Designed for continuous operation, providing up to 70% heat recovery
- Controls condensation and eliminates mould
- Speed controllable
- Quiet operation
- Washable filters



Heat Recovery Ventilation

The HR300 provides ventilation with heat recovery. It is ideal for light commercial applications including function rooms, offices, classrooms etc. The HR300 unit comes complete with an integral shutter.

Performance

The HR300 unit is designed for continuous operation providing up to 70% heat recovery. Effectively lowering internal relative humidity the HR300 unit controls condensation and eliminates mould.

Fresh, pre-warmed air from the outside is continually supplied to the room with simultaneous extraction of stale moist air and smells. Heat is transferred via a unique plastic heat exchanger from outgoing air to the fresh air supply with no cross contamination, maintaining internal temperatures and providing a fresh indoor environment.

The unit is fully controllable for speed using a small dedicated speed controller. Automatic ON/OFF control or switching to boost is easily achieved using sensors/timers e.g. humidistat. For summer operation the heat exchanger can be removed and replaced with a plastic divider board to provide positive cooling to rooms.

Installation

The HR300 unit requires a 380mm x 280mm hole. Units should be level and square in the wall. The unit should be fitted so that it overhangs by a minimum of 50mm on the inside, and a minimum of 70mm on the outside. An extension sleeve is available for walls up to 650mm thick.

Maintenance

The heat exchanger should be washed in warm soapy water every twelve months, or as conditions necessitate. Access to the filter and heat exchanger is via two screws on the internal grille.

Filters should be cleaned by washing every six months or as conditions necessitate. Replacement filters can be purchased in packs of two.

Models

Model	Stock Ref
HR300	370394

Accessories

Model	Stock Ref
Filters	370402
Extension Sleeve	370422
Electronic Controller	W300310

SEC Class

Model	SEC Class
HR300	B

Dimensions (mm)

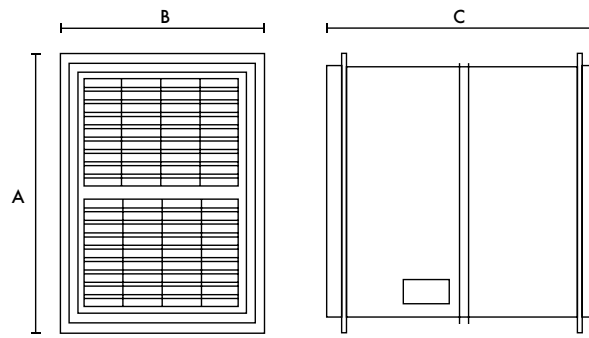

A	B	C
370	270	400

Weight 11kg

Performance

Model	Extract Performance l/s (m ³ /h)			Intake Performance l/s (m ³ /h)			Max Watts	Sound dB(A) @ 3m			SEC Class (inc. LDC)	SEC Class (inc. LDC)
	Low	Normal	Boost	Low	Normal	Boost		Low	Normal	Boost		
HR300	20 (75)	58 (210)	83 (300)	19 (70)	52 (190)	75 (270)	108	37	40	44	B	A

MVHR for Residential & Commercial Applications













Vent-Axia offers a complete range of Mechanical Ventilation with Heat Recovery (MVHR) units for residential and commercial applications, including many that are recognised in the SAP Product Characteristics Database.

Lo-Carbon Sentinel Kinetic® Advance

Our multi award winning MVHR system incorporates a range of unique features. Offering flexible commissioning through our Wi-Fi or App control options, along with integrated digital controls for easy installation the range is designed with developers, specifiers and installers in mind. With over 93% efficiency and low specific fan powers down to 0.38 W/l/s; designers will see a reduction in their dwelling emission rate.

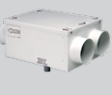
Vent-Axia®



	Lo-Carbon Sentinel Kinetic [®] Advance MVHR Unit	F:3-F:6
	Lo-Carbon Sentinel Kinetic [®] Range Overview	F:7-F:10
	Lo-Carbon Sentinel Kinetic [®] MVHR Unit	F:11-F:14
	Lo-Carbon Sentinel Kinetic [®] FH MVHR Unit	F:2-F:18
	Lo-Carbon Sentinel Kinetic [®] Plus MVHR Unit	F:19-F:22
	Lo-Carbon Sentinel Kinetic [®] High Flow MVHR Unit	F:23-F:26
	Lo-Carbon Sentinel Kinetic [®] Cooker Hood MVHR Unit	F:27-F:30
	Lo-Carbon Sentinel Kinetic [®] Horizontal MVHR Unit	F:31-F:36
	Lo-Carbon Kinetic [®] Plus E MVHR Unit	F:37-F:40
	Integra Ducted MVHR Unit	F:41-F:42
	Integra Plus EC Ducted MVHR Unit	F:43-F:44
	HR100R/RS Ducted MVHR Unit	F:2-F:46
	HR200V Ducted MVHR Unit	F:47-F:48
	HR500 Single Room Heat Recovery Unit	F:49-F:50
	HR500D Ducted MVHR Unit	F:51-F:52
	HR500EP/IP Passive HR Unit	F:53-F:54
	HR500DP Passive HR Unit	F:55-F:56

Lo-Carbon Sentinel Kinetic Advance

- Backlit user interface
- Lightweight for easier installation
- Full summer bypass
- Approved Document F aligned commissioning wizard
- Smartphone connectivity as standard
- Left/Right handing through the controller
- Pre-heater option for cold climates
- Post-heater control option
- Developed and manufactured in the UK
- ISO ePM10 and ePM2.5 filter options
- Acoustic Enclosure option for reduced breakout noise
- Acoustic Top Box option for reduced in-duct noise



The award winning Sentinel Kinetic[®] Advance from Vent-Axia is the next generation of heat recovery ventilation systems. It is designed to offer the highest level of comfort and control available ensuring the best possible customer experience.

A whole new experience

The highly sculpted interior surfaces, designed using the latest CFD techniques, ensures airflows are maximised through the unit, minimising noise and energy use. This feature alone provides an experience which we are confident will delight home owners and fulfil our ambition of providing the most discrete and efficient ventilation available.

With the widest range of options available, installers can now order a system that is tailored to their client's needs.

Air Quality and Health

We have strived to make the Advance system the most flexible solution available on the market. Optimisation has been targeted in every aspect of the design to ensure that it really does improve quality of life. Whatever the outside environment, we have a method to help reduce air pollution from entering the living space. Our range of filter options, up to and including ePM2.5 (F7), ensures that even homes in heavily urbanised areas have the opportunity to filter out the impurities and help protect their family from respiratory issues.

Low noise levels

The most common concern with home owners is that ventilation devices create noise. With Advance, absolute optimisation of every element does everything possible to minimise generation and transmission of both motor and airflow noise. We believe that we have one of the quietest units available. The Sentinel Kinetic Advance Acoustic Solution is also available for scenarios where noise is critical; an Acoustic Enclosure will reduce breakout noise and the Top Box will reduce in-duct noise at key frequencies.

Ventilation how you want it

The Vent-Axia Connect smartphone application, available on iOS and Android, allows the multitude of functions to be adjusted from the comfort of your sofa.

We have spent our time considering every element of the ventilation control. Should you want to run the system at certain times and a various speed, all the options are available. With smartphone compatible controls, you are in full control of your ventilation all year round, for example increasing the ventilation rate during hot periods in the summer or reducing the speed while away to minimise running costs.

Simultaneously, the smart logic built within our controls also ensures that your system operates optimally, with automated functions such as frost protection and summer bypass, ensuring your comfort is the number one priority.



Airtight Buildings

Low energy buildings typically have very low leakage rates (below 3m³/(h.m²) at 50Pa). This reduces the effectiveness of the standard frost protection strategy which imbalances the airflows. For airtight buildings in cold climates it is advisable to use the Sp models with built-in pre-heater.

SEC Class

Model	SEC Class
Advance S/SX	A+

Model

Model	Stock Ref
Advance S	405215
Advance S with Acoustic Top Box & Enclosure	479550
Advance S with Acoustic Top Box	479549
Advance S with Acoustic Enclosure	479548
Advance SX	405216
Advance SX with Acoustic Top Box & Enclosure	479553
Advance SX with Acoustic Top Box	479552
Advance SX with Acoustic Enclosure	479551
Advance Sp LH	476808
Advance Sp RH	476809

Accessories

Model	Stock Ref
Volt-free Expansion (Four additional inputs)	472697
Switched Live Expansion (Two additional inputs)	472699
0V - 10V Input Board (Two inputs)	472701
Acoustic Purge Fan	477988
Acoustic Purge Fan XL	479829

Spare Filters

Model	Stock Ref
ISO 45% Coarse (G3) 2x Filter	472667
ISO ePM10 50% Pollen (M5) 1x Filter	472669
ISO ePM2.5 70% Fine (F7) 1x Filter	472671

SAP PCDB Test Results

	SAP 2009		SAP 2012	
	Thermal Efficiency %	SFP (W/l/s)	Thermal Efficiency %	SFP (W/l/s)
K+1	93	0.38	93	0.39
K+2	93	0.38	92	0.46
K+3	92	0.42	91	0.55
K+4	92	0.50	91	0.70
K+5	91	0.58	90	0.85
K+6	91	0.68	89	1.07
K+7	90	0.82	89	1.31

Spigot Configuration

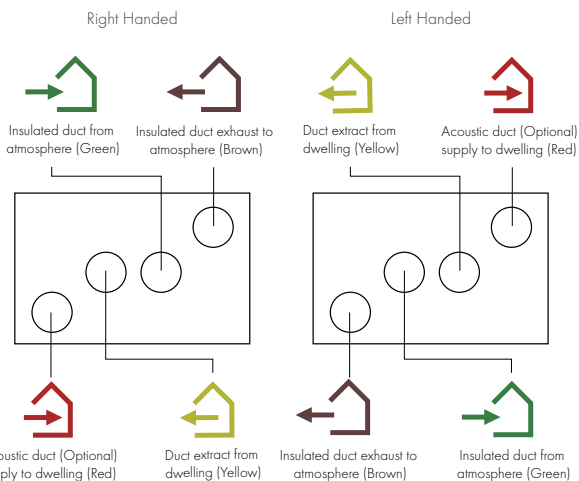

Hand-able through controller (except if pre-heater fitted)

Model Range Overview

Models	Advance S	Advance SX	Advance Sp
Acoustic Enclosure	○	○	X
Acoustic Top Box	○	○	X
App Control	✓	✓	✓
App Commissioning	✓	✓	✓
Auto Summer Bypass	✓	✓	✓
Easy Access Filters	✓	✓	✓
ISO 45% Coarse (G3) Filter	✓	✓	✓
ISO ePM10 50%, ePM2.5 70% Filter Options	✓	✓	✓
Very Low Noise Levels	✓	✓	✓
Built-In Humidistat	✓	✓	✓
Active Frost Protection to -20°C	✓	✓	✓
Delay-On	✓	✓	✓
Clean Filter Indicator (Time)	✓	✓	✓
Clean Filter Indicator (Pressure)	X	✓	X
Fault Code Indicator	✓	✓	✓
Switched Live	✓	✓	✓
Volt Free	✓	✓	✓
0V - 10V Proportional Control	○	○	○
Lightweight	✓	✓	✓
22mm or 32mm Condensate Connection	✓	✓	✓
Left/Right Orientation Through Control	✓	✓	✓
PIN Number Lock	✓	✓	✓
Running Time Indicator	✓	✓	✓
External Pre-Heater Controller	○	○	○
External Post-Heater Controller	○	○	○
Built-in Pre-Heater	X	X	✓
Enthalpy Heater Exchanger	○	○	○
Fan Curve Flow	✓	✓	✓
Constant Volume	X	✓	X
Soft-Start Boost	✓	✓	✓

Mounting Options

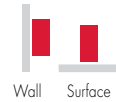

○ - Optional extra. Contact us for more information.

Dimensions (mm)

Unit

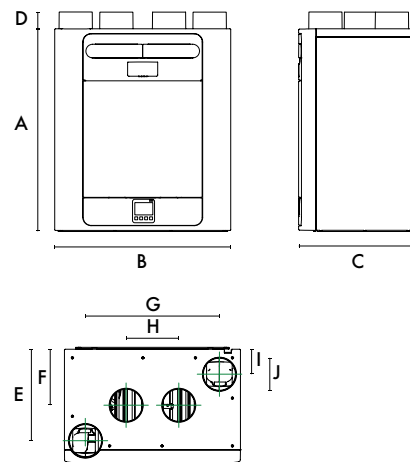

A	B	C	D	E	F	G	H	I	J	kg
760	660	443	63	343	210	503	197	93	125	27

Packed weight: 32kg

Dimensions (mm) Cont.

Acoustic Solution

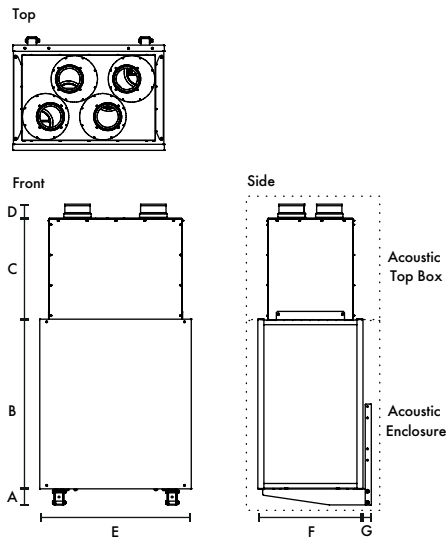

Acoustic Acoustic
Top Box Enclosure

A	B	C	D	E	F	G	kg	kg	Spigot
80	840	501	68	750	520	40	14	27	125

Performance

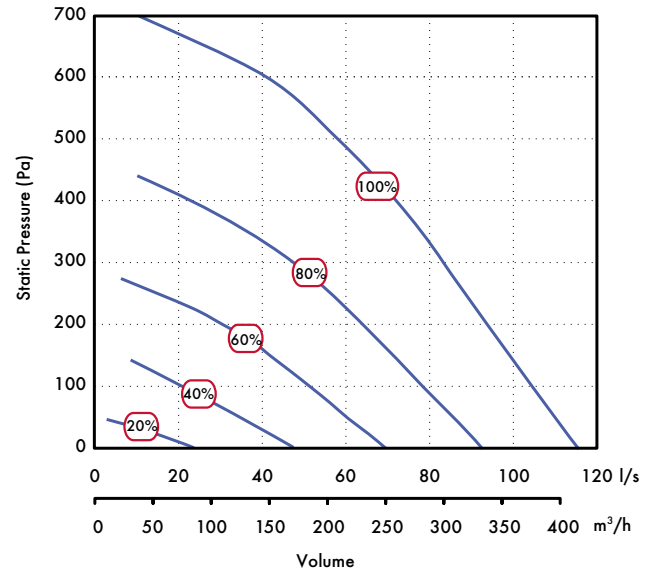

Sound Spectrum (Unit only)

Speed	Test mode	Octave Band (Hz) Sound Power Levels, dB								SPL dB(A) @ 3m	
		63	125	250	500	1k	2k	4k	8k		LwA
20%	Supply	52.9	50.9	46.8	43.0	34.6	27.1	19.2	25.4	43.9	26.4
	Extract	50.3	49.0	36.0	31.5	23.6	16.1	18.9	25.3	36.4	18.9
	Breakout	34.6	34.8	35.7	34.9	29.6	25.1	21.0	25.3	36.0	15.5
40%	Supply	59.5	56.5	59.4	55.0	48.2	42.6	31.8	26.1	55.9	38.4
	Extract	51.9	51.3	50.4	41.2	35.0	25.3	19.8	25.4	44.8	27.3
	Breakout	40.2	42.6	46.5	45.4	41.0	36.2	25.5	25.3	46.5	26.0
60%	Supply	66.9	62.4	63.3	62.0	57.9	53.5	43.4	34.2	63.2	45.7
	Extract	60.6	60.3	54.2	49.5	44.4	36.2	27.9	26.3	51.7	34.2
	Breakout	45.5	49.8	52.5	53.1	49.7	46.7	36.2	26.9	54.5	34.0
80%	Supply	82.4	67.6	65.2	67.6	64.2	60.8	50.8	43.2	69.2	51.7
	Extract	75.5	68.6	59.3	56.0	48.3	44.2	36.9	31.3	58.6	41.1
	Breakout	59.2	55.0	56.8	60.0	55.4	53.9	44.1	33.4	61.0	40.5
100%	Supply	79.4	69.6	66.6	75.1	64.9	63.6	53.4	45.7	73.7	56.2
	Extract	72.4	70.5	60.5	56.4	49.8	46.3	39.0	33.4	59.5	42.0
	Breakout	63.0	57.1	58.5	63.7	56.8	55.9	46.4	36.2	63.5	43.0

Sound Spectrum (Unit with Acoustic Solution)

Speed	Test mode	Octave Band (Hz) Sound Power Levels, dB								SPL dB(A) @ 3m	
		63	125	250	500	1k	2k	4k	8k		LwA
20%	Supply	54.7	50.5	41.5	30.8	18.6	14.7	18.2	24.0	38.0	20.5
	Extract	54.8	41.7	31.4	20.2	15.2	13.8	18.3	24.3	31.9	14.4
	Breakout	36.6	47.3	38.0	24.7	19.3	16.6	19.1	23.6	34.0	13.5
40%	Supply	61.0	57.7	56.0	39.0	27.5	16.6	18.4	24.1	48.9	31.4
	Extract	55.7	50.8	44.6	26.8	19.1	15.0	18.2	24.0	39.2	21.7
	Breakout	55.9	55.2	48.2	35.5	29.9	20.9	20.4	25.3	42.6	22.1
60%	Supply	64.5	64.3	56.2	48.6	36.0	22.8	19.0	24.2	52.3	34.8
	Extract	59.4	57.3	46.6	36.0	25.6	17.4	18.6	24.5	43.9	26.4
	Breakout	43.5	60.5	49.5	43.5	39.0	32.0	23.8	23.7	47.6	27.1
80%	Supply	68.9	65.9	59.9	53.9	41.4	29.3	21.6	24.7	55.9	38.4
	Extract	63.1	69.3	52.6	43.0	33.4	23.7	20.2	24.6	54.5	37.0
	Breakout	48.3	69.8	52.7	48.3	44.7	39.8	33.2	25.9	57.1	36.6
100%	Supply	72.5	70.5	63.1	56.1	43.9	33.0	23.7	25.2	59.3	41.8
	Extract	70.3	61.9	56.2	45.4	36.6	28.0	22.9	24.6	51.5	34.0
	Breakout	54.3	67.1	63.3	51.3	47.9	43.9	38.5	28.7	57.7	37.2

Tested according to BS EN 13141-7:2010. Breakout quoted spherical. Supply and Extract quoted hemispherical. For in-duct data, end reflections are added based on the spigot size of the unit.

Consultant's Specification

The supply and extract ventilation unit shall be the Sentinel Kinetic Advance as manufactured by Vent-Axia and shall be sized as indicated on the drawings and shall be in accordance with the particular specification.

The unit shall be fully insulated for thermal and acoustic performance and shall incorporate a counterflow multiplate heat exchanger with independently verified thermal efficiency up to 93%. The heat exchanger shall be protected by ISO 45% Coarse (G3) Grade filters on intake and extract air-flows. The unit shall have the facility to accommodate ISO ePM10 (M5) and ePM2.5 (F7) filters. The filters shall be accessible via tool-free access doors. The heat exchanger, motors, summer bypass and all other serviceable parts shall be accessible through the front of the unit.

Supply air to the room shall be pre-heated by the extract air via the integrated composite plastic counter-flow heat recovery cell. The Sentinel Kinetic shall automatically vary the ventilation rate via EC/DC motors, as it receives signals from optional or in-built sensor inputs. When a signal is received, the fans shall either vary their speed proportionally or on a trickle/boost principle.

The unit shall have the facility to commission the supply and extract fans individually via in-built minimum and maximum speed adjustment, or alternative wired remote control unit. The fans themselves shall have independent, infinitely variable speed control.

Unit Specification

The unit shall be manufactured with an ABS Outer case construction, with the ability to alter the spigot configuration via the on-board controller. The unit shall have a high efficiency composite plastic counter-flow heat exchanger, supply and extract filters (up to ISO ePM2.5 (F7)), automatic 100% summer bypass, integral minimum and maximum infinitely variable speed controls with fascia mounted failure indication.

The unit shall have low energy, high efficiency EC/DC fan/motor assemblies with sealed for life bearings. The impellers shall be high efficiency backward curved centrifugal type, achieving an SFP as low as 0.38W/l/s (EN 308).

The unit shall have a heat exchanger cell with a thermal efficiency of up to 93% when tested to EN 308. This shall be protected by ISO 45% Coarse (G3) grade synthetic filters on supply and extract, with the option of ISO ePM10 (M5), ISO ePM2.5 (F7) or external carbon activated filters. The unit shall come with both a 22mm and 32mm connection for draining condensation.

The unit shall have wireless control capabilities as standard, using RF858 connectivity, 802.11b/g/n Wi-Fi and Bluetooth low energy 4.2. The unit shall use RF858 to connect to a wide ecosystem of wireless sensors including but not limited to CO2, temperature, and relative humidity. The unit shall be able to engage Wi-Fi to connect to local devices and create a local area network to allow for a larger network to be created for commissioning. The unit shall have Bluetooth low energy 4.2 to allow connectivity onto compatible smart phone devices.

The unit shall be constructed with a removable tool-free front panel which gives access to the removable on-board controller and other accessories. The EPS panel can then be removed with 4 screws allowing full maintenance access. This shall provide access to the following:

- ✓ Supply or extract fan
- ✓ Heat exchanger
- ✓ Access to the electrical connections

To reduce breakout noise, the MVHR unit shall be provided with an Acoustic Enclosure of steel construction lined with class '0' acoustic foam. To reduce in-duct noise, the top of the MVHR shall be fitted with an Acoustic Top Box to provide attenuation to the 4 ducts of the unit. This Acoustic Top Box shall be of steel construction lined with acoustic class '0' foam with the MVHR spigots linked to the Top Box via 4 separate attenuated ducts. The acoustic enclosure and top box shall each be independently tested for noise to BS EN 13141-7.

Access shall be provided for wiring termination and setup/commissioning. The unit can be supplied with either a backlit user interface or a blank plate, both of which shall be removable for remote mounting if required. Filters shall be accessed via the two pull out drawers near the top of the unit.

Units shall be as manufactured by Vent-Axia Ltd.

Standard Controls

The Sentinel Kinetic Advance shall incorporate the following functions through a user interface fitted by the manufacturer or a paired smartphone with the Vent-Axia Connect application: -

- ✓ Integral infinitely variable fan speed control on supply and extract.
- ✓ 6 speeds; 4 adjustable
- ✓ Left or Right hand spigot configuration, programmable by the on board controller
- ✓ Filter change wizard which stops the motors during filter replacement
- ✓ 0-10V proportional speed adjustment
- ✓ Volt free contacts
- ✓ 24V external sensor supply, eg PIR sensor

- ✓ Filter check facility
- ✓ Tool free filter access
- ✓ Integral BMS interfaces - control and status indication
- ✓ Heating interlocks
- ✓ 0-10V proportional speed adjustment
- ✓ Fully automatic summer bypass
- ✓ Control panel pin number lock

The unit shall incorporate:

- ✓ An integral humidity sensor with the following features:
Ambient Response; Raises the humidity trigger point as dwelling temperature reduces.
- ✓ Rapid Response: Monitors the rate of change in humidity and triggers increased airflow even if the humidity trigger threshold is not reached.
- ✓ Proportional Response; incrementally increases the fan speed to reduce noise and reduce energy consumption.
- ✓ RS485 connectivity - Long distance cabling to support multiple sensor connection.
- ✓ RF858 connectivity - Radio reference 868 MHZ for multiple wireless sensors pairing Bluetooth low energy 4.2 - Enable pairing within compatible smartphone device
- ✓ 802.11b/g/n Wi-Fi - Enable localised access point or connecting onto local area network using the Vent-Axia Connect application, via compatible smartphone device
- ✓ The unit shall incorporate an automatic 100% summer bypass damper which monitors internal and external temperatures to maintain the user comfort temperature (default 21°C) :
- 'Evening Fresh' turns the unit to maximum speed with the bypass operational for 2 hours or until the user comfort temperature is reached (default 21°C).
- 'Night Time Fresh' will run the unit on maximum speed with the bypass operational throughout the night or until the dwelling reaches minimum temperature (default 14°C).

Independently acoustically tested to BS EN 13141-7:2010

Electrical Connection

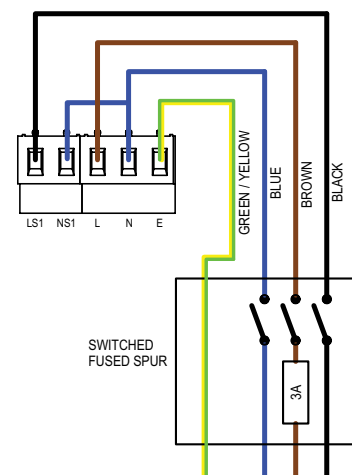

Lo-Carbon Sentinel Kinetic Range Overview

- Manufactured in the UK
- Building Regulations ADF and ADL compliant
- Recognised in SAP PCDB
- Specific Fan Power down to 0.4 W/l/s
- Up to 94% heat recovery
- Fully automatic Summer bypass
- Horizontal and/or vertical duct outlets
- Integrated digital controller for simple and accurate commissioning
- Lightweight for easy installation
- External condensate connection
- Plug and play controls; Humidistat, Wireless Remote
- Acoustic Enclosure option for reduced breakout noise
- Acoustic Top Box option for reduced in-duct noise

The Sentinel Kinetic Range Incorporates:

- A wholehouse heat recovery system with up to 94% energy efficiency
- An easily accessible heat recovery cell protected by two removable ISO 45% Coarse (G3) filters
- Two Lo-Carbon energy saving EC/DC fans which ensure long life (typically over double the life of AC motors) and lowest possible energy use
- Fully insulated construction with built-in condensation drain
- Specifically designed for new build constructions with a high level of insulation

The Lo-Carbon Sentinel Kinetic meets the latest requirements of the Building Regulations ADF and ADL for wholehouse system ventilation: Continuous mechanical supply and extract with heat recovery. The Lo-Carbon Sentinel Kinetic models have 3 fully adjustable speeds and a purge setting (maximum flow). Provided with the unit is a digital controller that can be used to preset the speeds to any required airflow within the performance range.

Integral Humidity Sensor

The integral humidity sensor (models with H suffix) increases speed in proportion to relative humidity levels, saving energy and reducing noise. The sensor also reacts to small but rapid increases in humidity, even if the normal trigger threshold is not reached. This unique feature ensures adequate ventilation, even for the smallest wet room. The night time relative humidity setback feature suppresses nuisance tripping as humidity gradually increases with falling temperature.

Acoustic Solution

For scenarios where noise is a critical issue, The Sentinel Kinetic Acoustic Solution is also available for all Sentinel Kinetic units. An Acoustic Enclosure will reduce breakout noise and the Acoustic Top Box will reduce in-duct noise at key frequencies. The acoustic solution sound data for each product can be found on the relevant product page.



Filtration

A new ISO filtration standard has come into force. The test method has changed so direct comparisons between EN779 2012 and ISO 16890 cannot be drawn. Below is a guide to the filter efficiencies:

ISO 16890	EN779
45% Coarse	G3
65% Coarse	G4
ePM10 50%	M5
ePM2.5 70%	F7

For sensors see Accessories & Controllers section.

Sentinel Control

The Sentinel controller is the most advanced system available, providing Demand Control Ventilation (DCV), minimising energy consumption and noise levels, and optimising ventilation performance. Sentinel controlled units may be set to operate fully automatically or with varying levels of manual intervention.

Building Management System (BMS) Options

There are two levels of BMS available: Basic Output and full Electronic BMS.

Basic Output provides a 5 volt output from the LED terminals on the controller. This output occurs whenever a message appears in the digital display, for example; 'Check Filters' or a fault code. The output can also be converted to volt-free with the addition of an optional Opto-Coupler.

Electronic BMS: A full range of two-way digital signals are available through the RJ11 connector on the control board. The BMS system provider will translate this signal to extract the desired data. Contact Vent-Axia to discuss your specific requirements.

LED Alarm

MVHR units are often installed in lofts or other locations where they are difficult to monitor. The optional remote LED alarm illuminates when any message is visible in the MVHR unit display panel. The LED alarm can be installed in a convenient location within the dwelling allowing end users to see that the unit requires attention.

Control Inputs

Five volt-free pairs of switch terminals for sensor inputs allow boosting from a full range of Vent-Axia controllers – humidistats, PIR, timers.

Two terminals with 0-24V outputs allow 0V to 10V proportional control by sophisticated controllers such as CO₂ sensors and proportional humidistats.

Switched-live for boosting via light switches (220-240V AC) or manual Normal/Boost switches. This connection has the advantage of Delay-On and Delay-Off facility. Delay-On enables you to prevent the Boost airflow between 0 and 10 minutes, after a light switch has been activated. Delay-Off allows the Boost airflow to continue after a light switch is turned off to ensure effective clearance of humidity. This timer is adjustable between 0 and 25 minutes.

The units can be boosted incrementally via the on-board controller or the Wired Remote Controller: One press = 30 minutes, two presses = 60 minutes, three presses = continuous.

Frost Protection

In order to prevent frost forming inside the unit in winter conditions, the Kinetic range employs a sophisticated frost protection strategy that modifies the airflows ensuring heat recovery continues down to -20°C. Below this temperature, the units will operate as 'extract only' fans. If balanced ventilation is required at low temperatures, a duct pre-heater should be used.

Optional Controls

Model	Stock Ref
LED Alarm with 15 metre cable	448356
Wired Remote Controller with 15 metre cable	443283

Purge Options

The unit can be set to maximum flow (100%) by pressing and holding the Boost button on the unit itself or optional wired controller for 5 seconds. Purge will continue for two hours unless cancelled by pressing the Boost button again.



In addition, the Acoustic Purge Fan can be used in conjunction with a Sentinel Kinetic MVHR unit or independently via a separate switched live connection or 0-10V external sensor input.

Model	Stock ref
Acoustic Purge Fan	477988
Acoustic Purge Fan XL	479829

Summer Bypass

An internal damper operates when the external temperature is below the internal temperature, and the internal temperature is too high.

The bypass opens and allows the cooler outside air to help cool the dwelling.

Normal mode: Fans run on Normal speed with bypass open until the internal dwelling temperature falls below the set 'Indoor' (maximum desired) temperature.

Evening Purge mode: The fans run on Boost speed until the internal temperature falls below the set 'Indoor' temperature. If, after five hours the internal temperature is still above the set 'Indoor' temperature, the unit will switch down to normal speed for the remainder of the 'bypass open' period.

Nighttime Purge mode: As Evening Purge, except that the unit will continue

on Boost speed until the internal air temperature reaches the 'Outdoor' temperature set point (Default 14°C). This mode gives pre-cooling of the dwelling for the following day.

In Evening and Night Time Purge modes, the user can turn off the boost function by pressing the Boost button.

A Summer Bypass can make a contribution to reducing internal temperatures but is not a substitute for appropriate design and construction.

System Cooker Hood Range

System canopy hoods are a motorless hood with extract being provided by the MVHR unit. When the Boost button on the canopy is activated, the MVHR unit goes to boost setting and the summer bypass opens preventing cooking by-products entering the heat exchanger cell. SELV hoods allow the distance between the hood and an electric hob to be reduced from 650mm to 550mm.



Model	Stock ref
White	407509
Aluminium	407206
White SELV	474790
Aluminium SELV	474791

Model Range Overview

Sentinel Kinetic Range

Kinetic E Range



Model Ranges	Lo-Carbon Sentinel Kinetic	Lo-Carbon Sentinel Kinetic FH	Lo-Carbon Sentinel Kinetic Plus	Lo-Carbon Sentinel Kinetic High Flow	Lo-Carbon Sentinel Kinetic Cooker Hood	Lo-Carbon Kinetic Plus E
Models	BH	FH	Plus	High Flow	CH	Plus E
Acoustic Enclosure	○	○	○	○		○
Acoustic Top Box	○	○	○	○		○
Auto Summer Bypass	✓	✓	✓	✓	✓	
Easy Access Filters	✓	✓	✓	✓	✓	✓
Very Low Noise Levels	✓	✓	✓	✓	✓	✓
Integral Cooker Hood					✓	
Built-In Humidistat	✓	✓	✓	✓	✓	
Kitchen Cupboard Installation	✓				✓	
Max Airflow @ 100Pa	68	79	117	185	68	117
Frost Protection	✓	✓	✓	✓	✓	✓
Delay-On	✓	✓	✓	✓	✓	✓
Wired Remote Control	○	○	○	○	○	
Wireless Boost	○	○	○	○	○	
Clean Filter Indicator (Time)	✓	✓	✓	✓	✓	✓
Fault Code Indicator	✓	✓	✓	✓	✓	✓
Potentiometer Adjustment						✓
Sentinel Control	✓	✓	✓	✓	✓	
Switched Live	✓	✓	✓	✓	✓	✓
Volt Free Contact	✓	✓	✓	✓	✓	
OV - 10V Proportional Control	✓	✓	✓	✓	✓	
BMS Input/Output	✓1	✓1	✓1	✓1	✓1	
Lightweight	✓	✓	✓	✓		✓
External Condensate	✓	✓	✓	✓	✓	✓
Horizontal Duct Option	✓	✓	✓	✓	✓	✓
Horizontal (Slab) Installation						
Left/Right Orientation	✓	✓	✓	✓	✓	✓
PIN Number Lock	✓	✓	✓	✓	✓	
Running Time Indicator	✓	✓	✓	✓	✓	
Enthalpy Heater Exchanger	○	○	○	○		
Mounting Options	Wall Surface	Wall Surface	Wall Surface	Wall Surface	Wall	Wall Surface

○ - Denote Optional, 1- Seek technical advice from Vent-Axia. *ZMH rectangular spigot model.

Sentinel Demand Control

The Lo-Carbon Sentinel Kinetic Range can be used with a wide range of optional Vent-Axia controllers and sensors. Ranging from integral humidistats, through wireless controllers to wired remote sensors.

Wired Remote Controller

- Standard with horizontal units, optional extra with vertical units
- Supplied with 15 metres of cable (max length), the Wired Remote Controller duplicates all the features of the on-board control panel, allowing commissioning, diagnosis and user control
- Flush mounting, suitable for a single gang pattress box 16mm deep



Stock Ref

443283

Ambient Response Humidity Sensor

- Pullcord override and neon indicator
- Changeover relay switch
- Operating range: 30% - 90%RH
- Ambient operating temp. 5°C to 40°C
- 220-240V AC
- Will fit single gang box for surface mounting



Stock Ref

563550

Ecotronic Humidity Sensor

- Set Point adjustable
- Maximum switching load 1 amp inductive
- Pullcord override indicator
- Ambient operating temp. 0°C to 40°C
- Supply voltage 220-240V



Stock Ref

563532

Air Quality Sensor

- Ambient operating temp. 0°C to 50°C
- Min - Max mode or direct damper control
- Surface mounted
- 1 - 25 min O/R timer
- Supply voltage 220-240V



Stock Ref

563506

Normal Boost Switch

- A single gang switch to boost from low to high speeds on heat recovery systems
- 85 x 85 x 10mm (H x W x D)



Stock Ref

455213

Visonex PIR Sensor

- Fits any UK single gang mounting box
- Adjustable timer overrun (5-25 mins)
- Range of detection up to 10 metres
- Designed to meet IP43
- Ambient operating temp. range 0°C to 50°C



Stock Ref

459623

Momentary Push Switch

- Compatible with Sentinel Kinetic range, the momentary switch boosts the unit for 30 minutes
- 85 x 85 x 10mm (H x W x D)



Stock Ref

448929

Normal Boost Switch with Light Indicator

- Single gang switch with LED illumination when in the Boost condition
- 85 x 85 x 10mm (H x W x D)

Stock Ref

449060



Normal Boost Switch - Stainless Steel

- A single gang switch to operate normal/boost functions on MVHR systems
- Brushed stainless steel finish
- 90 x 90 x 18 (H x W x D)

Stock Ref

437320



Isolator Relay Controller

- Allows fan unit to be isolated from other mains circuit when used with TIM2 trickle/boost switch or light switch control

Stock Ref

442030



Lo-Carbon Sentinel Kinetic BH

- Recognised in SAP PCDB
- Lightweight for easier installation
- Horizontal duct option for space-saving installations
- Fits within a 290mm deep kitchen cupboard
- Integrated digital controller for simple and accurate commissioning
- Plug and play controls; Humidistat, Wireless Remote
- BMS connectivity
- LS inputs (Light Switch)
- Horizontal duct options
- Acoustic Enclosure option for reduced breakout noise
- Acoustic Top Box option for reduced in-duct noise



Easy Installation

The Sentinel Kinetic models can be mounted vertically in a roof space, hallway cupboard or kitchen or within a kitchen cupboard. When mounted in an unheated area ducting and MVHR unit should be insulated. Ducting can be attached to the unit horizontally, vertically or both. Minimum internal depth of kitchen cupboard 290mm.

For scenarios where noise is a critical issue, an Acoustic Enclosure is available to reduce breakout noise and the Acoustic Top Box will reduce in-duct noise at key frequencies.

Left (L) or right (R) hand installation. The unit is supplied with duct spigots to outside on the right hand side. These can be reversed on site by simply removing the control panel, rotating the unit 180 degrees and re-attaching the control panel.

Spigot Options

The combination of spigot options allows installation in confined locations. If vertical and horizontal connection is required on the same outlet/inlet, additional spigots can be supplied.

The condensate drain can be taken out through the back, side or bottom of the unit. Using the fittings supplied, the final condensate connection is made outside the unit and can be completed after installation.

Integral Humidity Sensor (BH Models)

The integral humidity sensor increases speed in proportion to relative humidity levels, saving energy and reducing noise. The sensor also reacts to small but rapid increases in humidity, even if the normal trigger threshold is not reached. This unique feature ensures adequate ventilation, even for the smallest wet room. The night time relative humidity setback feature suppresses nuisance tripping as humidity gradually increases with falling temperature.

Models

Model	Stock Ref
Kinetic VS Right	438342
Kinetic BH Right	443319
Kinetic BH Right with Acoustic Enclosure & Top Box	479526
Kinetic BH Right with Acoustic Top Box	479525
Kinetic BH Right with Acoustic Enclosure	479524
Kinetic BH Left	443319L
Kinetic BH Left with Acoustic Enclosure & Top Box	479529
Kinetic BH Left with Acoustic Top Box	479528
Kinetic BH Left with Acoustic Enclosure (BH with summer bypass & humidity sensor)	479527

Accessories

Model	Stock Ref
Wired Remote Controller	443283
LED alarm with 15m cable	448356
Acoustic Purge Fan	477988
Acoustic Purge Fan XL	479829
ISO 45% Coarse (G3) 2x Filter	442356
ISO ePM10 50% Pollen (M5) 1x Filter	444199
Anti Vibration Mounts	68MP033G

SAP PCDB performance (Kinetic VS)

	SAP 2009		SAP 2012	
	Thermal		Thermal	
	Efficiency %	SFP (W/l/s)	Efficiency %	SFP (W/l/s)
K+1	90	0.60	90	0.61
K+2	90	0.59	90	0.74
K+3	90	0.68	90	0.95
K+4	89	0.79	90	1.19
K+5	90	0.97	-	-

SEC Class

Model	SEC Class
Kinetic VS & BH	A

Dimensions (mm)

Unit

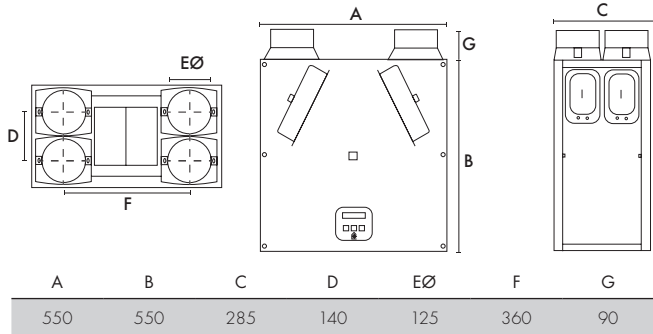

Weight: 15kg

Acoustic Solution

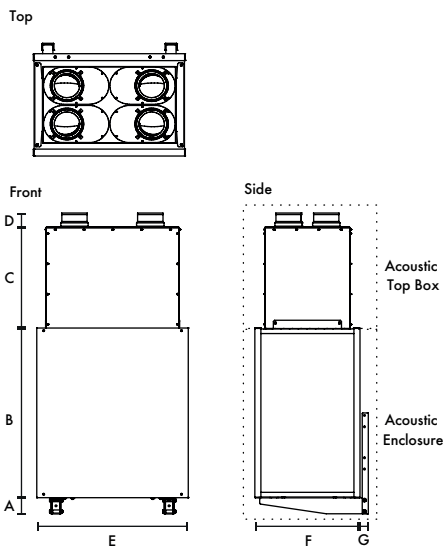

Acoustic Acoustic
Top Box Enclosure

A	B	C	D	E	F	G	kg	kg	Spigot
80	633	501	75	626	447	45	11	19	125

Sound Data (Kinetic VS & BH)

Speed	Test mode	Octave band, Hz, dB SWL								SPL dB(A) @ 3m	
		63	125	250	500	1k	2k	4k	8k		LwA
20%	Supply	52.9	52.9	46.5	41.7	39.3	29.3	19.3	22.8	44.4	26.9
	Extract	50.7	41.9	37.4	34.5	29.8	17.7	17.4	22.7	35.7	18.2
	Breakout	36	34.5	33.6	34.3	33.8	27.2	22.2	25.3	37.2	16.7
40%	Supply	57.1	64.1	56.8	50.6	49.7	41.1	32.8	26.4	54.7	37.2
	Extract	55.2	50.3	44.9	43	38.3	27.7	19.8	22.9	43.8	26.3
	Breakout	43.5	41.7	40.4	41.3	41.7	36.1	27.8	26.2	44.7	24.2
60%	Supply	71.3	72.5	68.5	57.6	56.4	51.1	42.7	38.1	63.6	46.1
	Extract	60.2	56.3	52	48.8	44.8	35.5	26.9	24.4	50.2	32.7
	Breakout	50.7	47.8	47.7	47.7	48.3	44.9	36.7	30	51.8	31.3
80%	Supply	66.3	74.8	71.2	62.8	61	56.3	49.8	46.7	67.3	49.8
	Extract	63.8	59.4	57.6	53.8	49.2	41.2	33.5	29	55.0	37.5
	Breakout	54.4	52.7	54	52.7	53.5	50.3	43.6	37.7	57.2	36.7
100%	Supply	70.3	75.7	73.9	66.3	63.5	59.7	53.2	50.6	70.0	52.5
	Extract	66.6	63.9	60.9	56.5	51.2	44.2	36.8	32.6	57.9	40.4
	Breakout	59.1	55.2	56.8	55.6	56.1	53.5	47.1	41.6	60.1	39.6

Tested according to BS EN 13141-7:2010. Breakout quoted spherical. Supply and Extract quoted hemispherical. For in-duct data, end reflections are added based on the spigot size of the unit.

Performance

Fan speeds are fully adjustable within the performance range.

Vertical Spigots

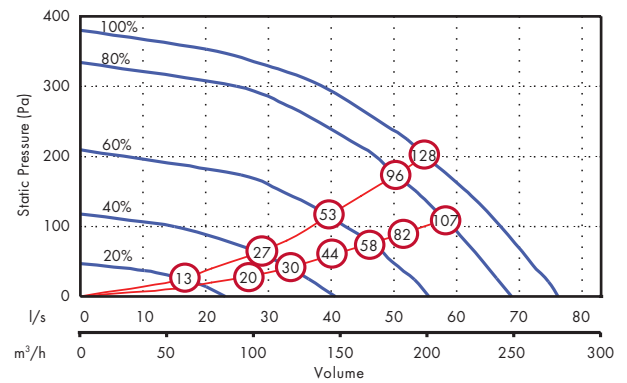

Horizontal Spigots

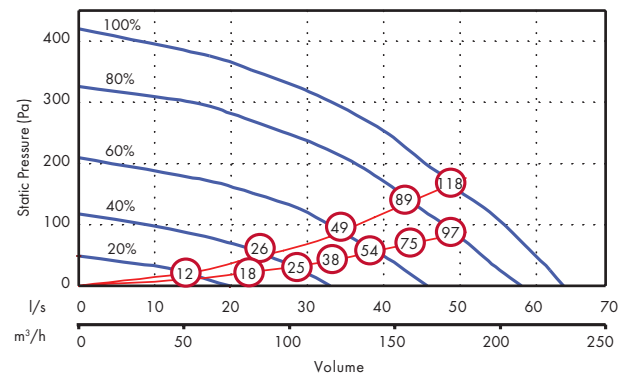

⊗ figure relates to Wattage (both motors)

Sound Data (Kinetic VS & BH with Acoustic Solution)

Speed	Test mode	Octave band, Hz, dB SWL								SPL dB(A) @ 3m	
		63	125	250	500	1k	2k	4k	8k		LwA
20%	Supply	57.1	44.6	36.4	27.9	20.6	14.8	18.1	23.8	35.2	17.7
	Extract	54.4	40.1	29.6	22.2	17.5	14.5	17.8	23.5	31.1	13.6
	Breakout	37.5	33.8	29.1	22.9	17.0	14.0	17.8	23.6	27.7	7.2
40%	Supply	64.9	56.3	46.4	36.1	28.2	15.4	18.1	23.8	44.6	27.1
	Extract	60.2	46.8	35.7	28.2	21.9	14.8	18.1	23.7	36.6	19.1
	Breakout	46.0	43.6	36.3	30.4	23.9	15.9	18.1	23.6	33.5	13.0
60%	Supply	72.3	63.0	55.6	43.1	34.1	19.5	18.6	24.0	51.9	34.4
	Extract	61.4	53.3	43.4	34.7	27.2	15.5	18.1	23.8	41.4	23.9
	Breakout	52.2	50.5	44.4	38.2	33.5	23.8	19.3	23.8	41.0	20.5
80%	Supply	73.8	67.9	61.6	50.0	38.6	23.4	20.2	25.2	56.8	39.3
	Extract	68.6	58.2	50.5	40.5	31.1	17.2	18.2	23.9	47.5	30.0
	Breakout	65.6	55.5	50.5	43.8	39.7	32.7	24.9	24.0	47.4	26.9
100%	Supply	77.3	70.8	64.9	53.8	41.4	26.3	21.9	26.8	60.1	42.6
	Extract	71.5	60.6	53.5	43.9	33.4	19.1	18.5	24.0	50.5	33.0
	Breakout	69.0	58.4	53.4	47.1	43.0	37.5	29.9	24.9	51.1	30.6

Consultant's Specification

Operation

The supply and extract ventilation unit shall be a Sentinel Kinetic as manufactured by Vent-Axia and shall be sized as indicated on the drawings and shall be in accordance with the particular specification.

Supply air to the room shall be pre-heated by the extract air via the integrated composite plastic counterflow heat recovery cell. The Sentinel Kinetic shall automatically vary the ventilation rate via EC/DC motors, as it receives signals from one of the optional interconnected sensors. When a signal is received, the fans shall either vary their speed proportionally or on a trickle and boost principle.

The unit shall have the facility to commission the supply and extract fans individually via in-built minimum and maximum speed adjustment, or alternative wired remote control unit. The fans themselves shall have independent, infinitely variable speed control.

Unit Specification

The unit shall be manufactured with an ABS outer case construction, and incorporate a reversible core to allow for left or right hand mounting.

The unit shall have a high efficiency composite plastic counterflow heat exchanger, supply and extract filters, automatic summer bypass, integral minimum and maximum infinitely variable speed controls with fascia mounted failure indication. The unit shall have low energy, high efficiency EC/DC fan/motor assemblies with sealed for life bearings. The impellers shall be high efficiency forward curved centrifugal type.

The unit shall have a heat exchanger cell with a thermal efficiency of up to 92% when tested to EN 308. This shall be protected by ISO 45% Coarse (G3) grade synthetic filters on supply and extract. Complete with a condensate drip tray and drain connection.

The unit shall be constructed with a removable Core allowing full maintenance access. The removable Core shall provide access to the following:

- ✓ Supply and extract filter
- ✓ Heat exchanger
- ✓ Access to the electrical connections

To reduce breakout noise, the MVHR unit shall be provided with an Acoustic Enclosure of steel construction lined with class 'O' acoustic foam. To reduce in-duct noise, the top of the MVHR shall be fitted with an Acoustic Top Box to provide attenuation to the 4 ducts of the unit. This Acoustic Top Box shall be of steel construction lined with acoustic class 'O' foam with the MVHR spigots linked to the Top Box via 4 separate attenuated ducts. The acoustic enclosure and top box shall each be independently tested for noise to BS EN 13141-7.

The MVHR unit shall incorporate an Expanded Polystyrene (EPS) inner chassis with custom motor and impeller mounting features. The inner chassis will assist in reducing noise and act as a large anti-vibration mount avoiding transmission through to the back mounting plate or the base of the unit.

The MVHR unit shall be tested to ensure it meets the maximum allowable vibration of no more than 1 mm/s, measured on the unit wall fixing points.

Access shall be provided for wiring termination and setup/commissioning. The backlit LCD user interface therein shall be removable for remote mounting if required.

Units shall be as manufactured by Vent-Axia Ltd.

Standard Controls

All Sentinel Kinetic units shall incorporate the following functions integrally mounted, pre-wired and factory fitted by the manufacturer:

- ✓ Integral infinitely variable fan speed control on supply and extract
- ✓ Integral min/max ventilation control/set point
- ✓ Integral BMS interfaces - control and status indication
- ✓ Heating interlocks
- ✓ 0-10V proportional speed adjustment
- ✓ Volt free contacts
- ✓ 24V sensor supply
- ✓ Integral on/off or trickle boost function from remote switch e.g. PIR occupancy detector
- ✓ The unit shall be controlled by the 'Sentinel' control devices (enablers and sensors) as detailed in the schedule or on the drawings
- ✓ Fully automatic summer bypass
- ✓ Switched Live input with adjustable 'delay-on' feature
- ✓ Fan failure or component failure indicated via individual fault code display
- ✓ Running time counter
- ✓ Control panel PIN number lock
- ✓ Automatic frost protection effective to -20°C
- ✓ Tool free filter access
- ✓ The unit shall incorporate ('H' models) an integral humidity sensor with the following features:
 - Ambient Response; Raises the humidity trigger point as dwelling temperature reduces
 - Rapid Response; Monitors the rate of change in humidity and triggers increased airflow even if the humidity trigger threshold is not reached
 - Proportional Response; Incrementally increases the fan speed to reduce noise and reduce energy consumption

Mounting Option

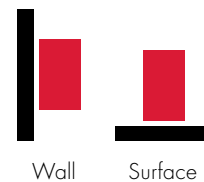

Airflow Direction

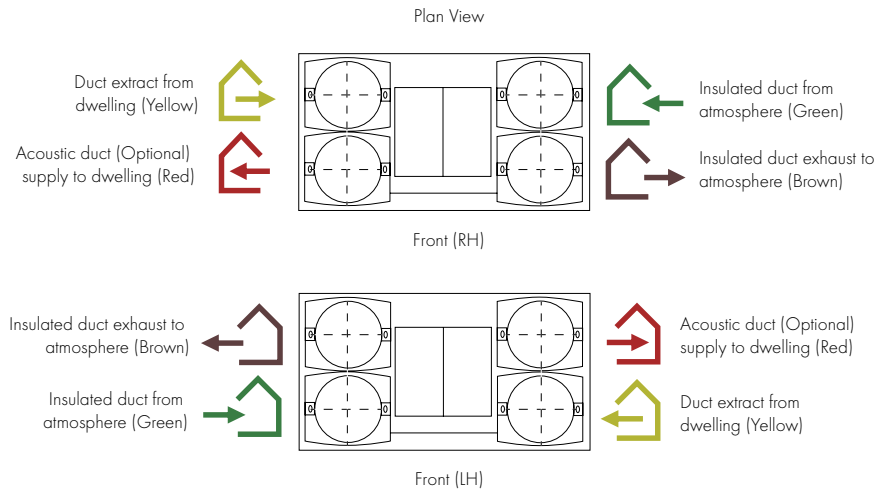

Electrical Connection

Please note: Electrical connection should be carried out by an appropriately qualified person and in accordance with current wiring regulations.

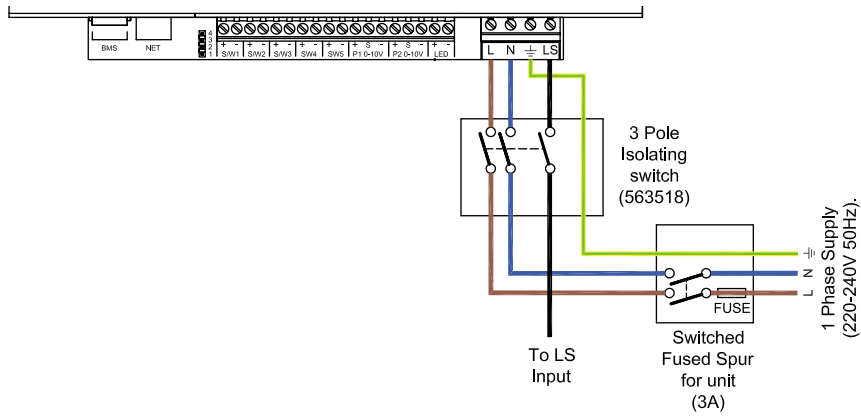

Trickle to Boost by Trickle/Boost Switch

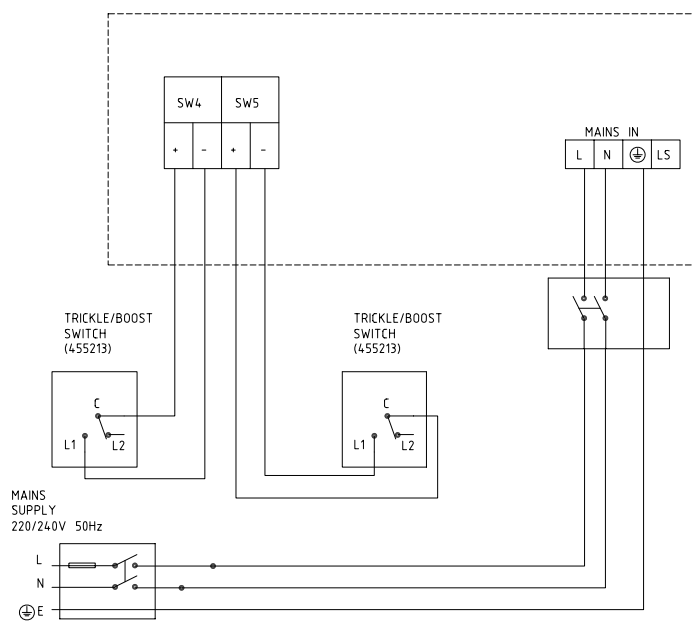

Lo-Carbon Sentinel Kinetic FH

- Acoustic Enclosure option for reduced breakout noise
- Acoustic Top Box option for reduced in-duct noise
- Lightweight for easier installation
- Horizontal duct option for space-saving installations
- Integrated digital controller for simple and accurate commissioning
- Plug and play controls; Humidistat, Wireless Remote
- BMS connectivity
- LS inputs (Light Switch)
- Volt-free inputs
- Self diagnosis for simplified fault finding
- Adjustable delay On/delay Off timer



Easy Installation

The Sentinel Kinetic models can be mounted vertically in a roof space or in an appropriate cupboard within the dwelling. When mounted in an unheated area the ducting and unit must be insulated in accordance with the Domestic Ventilation Compliance Guide. Ducting can be attached to the unit horizontally, vertically or both.

For scenarios where noise is a critical issue, an Acoustic Enclosure is available to reduce breakout noise and the Acoustic Top Box will reduce in-duct noise at key frequencies.

Left (L) or right (R) hand installation. Left hand and right hand units are available.

Spigot Options

The combination of spigot options allows installation in confined locations. If vertical and horizontal connection is required on the same outlet/inlet, additional spigots can be supplied.

The condensate drain can be taken out through the back, side or bottom of the unit. Using the fittings supplied, the final condensate connection is made outside the unit and can be completed after installation.

Integral Humidity Sensor

The integral humidity sensor increases speed in proportion to relative humidity levels, saving energy and reducing noise. The sensor also reacts to small but rapid increases in humidity, even if the normal trigger threshold is not reached. This unique feature ensures adequate ventilation, even for the smallest wet room. The night time relative humidity setback feature suppresses nuisance tripping as humidity gradually increases with falling temperature.

Model

Model	Stock Ref
Sentinel Kinetic FH Right	408167
Sentinel Kinetic FH Right with Acoustic Top Box & Enclosure	479532
Sentinel Kinetic FH Right with Acoustic Top Box	479531
Sentinel Kinetic FH Right with Acoustic Enclosure	479530
Sentinel Kinetic FH Left	408169
Sentinel Kinetic FH Left with Acoustic Top Box & Enclosure	479535
Sentinel Kinetic FH Left with Acoustic Top Box	479534
Sentinel Kinetic FH Left with Acoustic Enclosure	479533

(FH comes with summer bypass & humidity sensor)

Accessories

Model	Stock Ref
Wired Remote Controller	443283
LED alarm with 15m cable	448356
ISO 45% Coarse (G3) 2x Filter	409764
ISO ePM10 50% Pollen (M5) 2x Filter	472153
Anti Vibration Mounts	68MP033G
Acoustic Purge Fan	477988
Acoustic Purge Fan XL	479829

SAP PCDB performance

	SAP 2009		SAP 2012	
	Thermal		Thermal	
	Efficiency %	SFP (W/l/s)	Efficiency %	SFP (W/l/s)
K+1	90	0.46	89	0.47
K+2	89	0.45	88	0.54
K+3	88	0.50	86	0.65
K+4	87	0.60	84	0.84
K+5	85	0.70	84	1.01

SEC Class

Model	SEC Class
Kinetic FH/FHL	A+

Dimensions (mm)

Unit

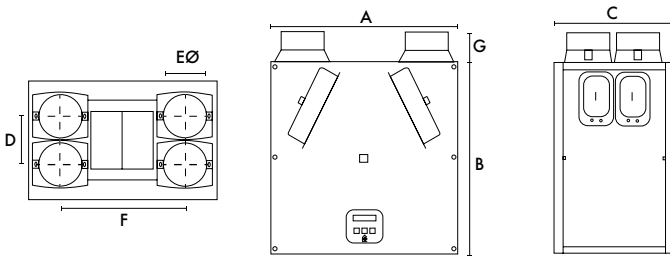

A	B	C	D	EØ	F	G
555	550	350	140	125	360	90

Weight: 18kg

Acoustic Solution

Top

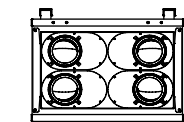

Front

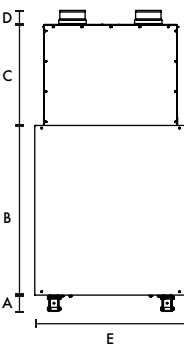

Side

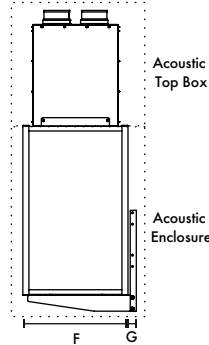

Acoustic Acoustic
Top Box Enclosure

A	B	C	D	E	F	G	kg	kg	Spigot
80	633	501	75	626	447	45	11	19	125

Performance

Fan speeds are fully adjustable within the performance range.

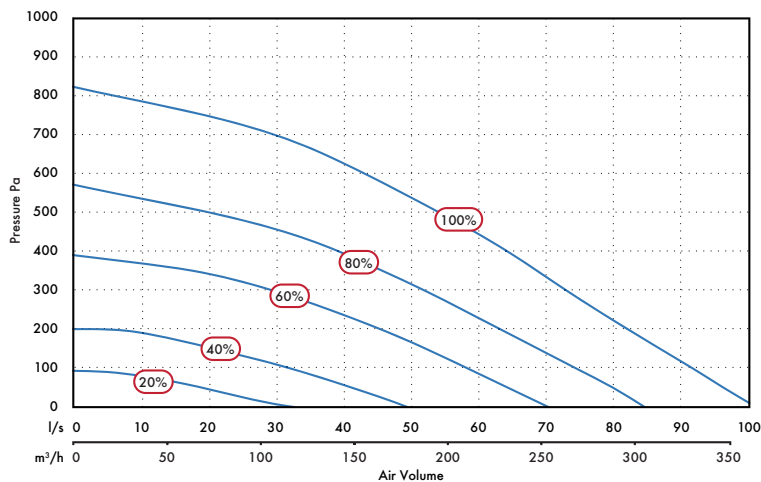

Sound Data (Unit only)

Speed Test mode	Port	Octave band, Hz, dB SWL								SPL dB(A)	
		63	125	250	500	1k	2k	4k	8k	LwA	@ 3m
20%	Supply	66.2	67.2	54.3	48.0	42.1	33.3	22.5	25.6	53.9	36.4
	Extract	57.7	56.6	47.2	43.5	35.3	24.1	19.6	25.7	45.7	28.2
	Breakout	41.2	47.0	41.7	39.5	34.6	30.4	22.5	25.7	41.0	20.5
40%	Supply	68.9	66.4	68.8	57.8	52.1	44.9	35.3	28.8	62.4	44.9
	Extract	66.8	56.1	56.9	52.1	44.7	34.6	23.8	25.8	53.2	35.7
	Breakout	47.3	47.5	56.4	48.0	44.0	39.6	32.8	29.1	51.0	30.5
60%	Supply	72.8	72.5	82.2	64.4	59.9	53.8	46.2	40.3	74.4	56.9
	Extract	67.3	61.9	66.5	58.9	52.2	42.7	32.6	27.6	61.1	43.6
	Breakout	53.9	53.2	65.9	55.8	52.2	48.2	42.5	39.3	61.0	40.5
80%	Supply	85.0	75.3	72.5	77.9	65.3	58.8	52.1	47.4	76.0	58.5
	Extract	83.5	65.2	65.0	65.5	57.0	47.7	37.9	31.3	65.5	48.0
	Breakout	56.4	56.4	60.4	69.8	56.7	53.2	47.8	42.0	66.5	46.0
100%	Supply	95.5	77.7	74.0	80.4	68.7	62.9	56.9	52.4	79.1	61.6
	Extract	83.3	68.3	66.9	71.2	60.7	51.4	42.4	36.1	69.7	52.2
	Breakout	62.1	59.7	62.9	70.0	61.0	57.3	52.3	46.9	68.0	47.5

Sound Data (Unit with Acoustic Solution)

Speed Test mode	Port	Octave band, Hz, dB SWL								SPL dB(A)	
		63	125	250	500	1k	2k	4k	8k	LwA	@ 3m
20%	Supply	58.2	62.1	46.8	33.7	21.1	14.1	18.2	24.1	47.5	30.0
	Extract	55.9	48.3	37.1	26.8	17.7	14.5	18.0	23.7	36.2	18.7
	Breakout	41.8	45.1	38.7	29.1	18.4	13.7	17.8	23.5	34.7	14.2
40%	Supply	66.5	59.3	59.3	43.5	30.5	15.9	17.9	23.5	52.1	34.6
	Extract	57.4	49.7	50.9	36.2	23.5	15.0	18.1	23.7	43.5	26.0
	Breakout	47.1	47.6	49.8	38.4	30.2	21.0	18.5	23.6	42.6	22.1
60%	Supply	69.5	66.0	66.5	50.7	40.2	20.6	18.8	24.2	59.3	41.8
	Extract	62.4	57.1	53.7	43.2	32.5	19.5	18.5	23.8	48.0	30.5
	Breakout	51.8	54.5	54.4	45.2	38.9	32.1	24.4	24.0	49.0	28.5
80%	Supply	78.5	68.9	63.3	61.3	45.1	25.7	20.7	25.8	61.0	43.5
	Extract	74.2	59.8	55.8	49.9	37.8	24.4	20.5	23.9	52.4	34.9
	Breakout	57.6	57.6	56.4	52.0	43.7	38.0	31.6	25.6	52.2	31.7
100%	Supply	75.7	70.8	67.1	65.7	48.2	30.4	23.6	27.8	64.6	47.1
	Extract	75.6	62.9	59.5	53.1	42.2	29.4	24.3	24.7	55.7	38.2
	Breakout	64.3	59.8	60.3	56.8	47.1	42.2	36.9	28.8	56.4	35.9

Tested according to BS EN 13141-7:2010. Breakout quoted spherical. Supply and Extract quoted hemispherical. For in-duct data, end reflections are added based on the spigot size of the unit.

Consultant's Specification

Operation

The supply and extract ventilation unit shall be a Sentinel Kinetic as manufactured by Vent-Axia and shall be sized as indicated on the drawings and shall be in accordance with the particular specification.

Supply air to the room shall be pre-heated by the extract air via the integrated composite plastic counterflow heat recovery cell. The Sentinel Kinetic shall automatically vary the ventilation rate via EC/DC motors, as it receives signals from one of the optional interconnected sensors. When a signal is received, the fans shall either vary their speed proportionally or on a trickle and boost principle.

The unit shall have the facility to commission the supply and extract fans individually via in-built minimum and maximum speed adjustment, or alternative wired remote control unit. The fans themselves shall have independent, infinitely variable speed control.

Unit Specification

The unit shall be manufactured with an ABS outer case construction, and incorporate a reversible core to allow for left or right hand mounting.

The unit shall have a high efficiency composite plastic counterflow heat exchanger, supply and extract filters, automatic summer bypass, integral minimum and maximum infinitely variable speed controls with fascia mounted failure indication. The unit shall have low energy, high efficiency EC/DC fan/motor assemblies with sealed for life bearings. The impellers shall be high efficiency backward curved centrifugal type.

The unit shall have a heat exchanger cell with a thermal efficiency of up to 90% when tested to EN 308. This shall be protected by ISO 45% Coarse (G3) grade synthetic filters on supply and extract. Complete with a condensate drip tray and drain connection.

To reduce breakout noise, the MVHR unit shall be provided with an Acoustic Enclosure of steel construction lined with class 'O' acoustic foam. To reduce in-duct noise, the top of the MVHR shall be fitted with an Acoustic Top Box to provide attenuation to the 4 ducts of the unit. This Acoustic Top Box shall be of steel construction lined with acoustic class 'O' foam with the MVHR spigots linked to the Top Box via 4 separate attenuated ducts. The acoustic enclosure and top box shall each be independently tested for noise to BS EN 13141-7.

The MVHR unit shall incorporate an Expanded Polystyrene (EPS) inner chassis with custom motor and impeller mounting features. The inner chassis will assist in reducing noise and act as a large anti-vibration mount avoiding transmission through to the back mounting plate or base of the unit.

The MVHR unit will be tested to ensure it meets the maximum allowable vibration of no more than 1 mm/s, measured on the unit wall fixing points.

The unit shall be constructed with a removable Core allowing full maintenance access. The removable Core shall provide access to the following:

- ✓ Supply and extract filter
- ✓ Heat exchanger
- ✓ Access to the electrical connections

Access shall be provided for wiring termination and setup/commissioning. The backlit LCD user interface therein shall be removable for remote mounting if required.

Units shall be as manufactured by Vent-Axia Ltd.

Acoustically tested to BS EN 13141-7

Standard Controls

All Sentinel Kinetic units shall incorporate the following functions integrally mounted, pre-wired and factory fitted by the manufacturer:

- ✓ Integral infinitely variable fan speed control on supply and extract
- ✓ Integral min/max ventilation control/set point
- ✓ Integral BMS interfaces – control and status indication
- ✓ Heating interlocks
- ✓ 0-10V proportional speed adjustment
- ✓ Volt free contacts
- ✓ 24V sensor supply
- ✓ Integral on/off or trickle boost function from remote switch e.g. PIR occupancy detector
- ✓ The unit shall be controlled by the 'Sentinel' control devices (enablers and sensors) as detailed in the schedule or on the drawings
- ✓ Fully automatic summer bypass
- ✓ Switched Live input with adjustable 'delay-on' feature
- ✓ Fan failure or component failure indicated via individual fault code display
- ✓ Running time counter
- ✓ Control panel PIN number lock
- ✓ Automatic frost protection effective to -20°C
- ✓ Tool free filter access
- ✓ The unit shall incorporate ('H' models) an integral humidity sensor with the following features:
 - Ambient Response; Raises the humidity trigger point as dwelling temperature reduces
 - Rapid Response; Monitors the rate of change in humidity and triggers increased airflow even if the humidity trigger threshold is not reached
 - Proportional Response; Incrementally increases the fan speed to reduce noise and reduce energy consumption

Airflow Direction

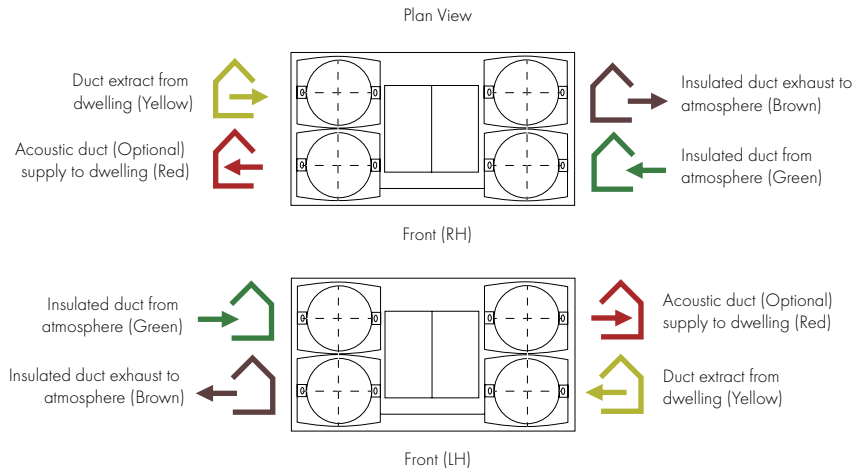

Electrical Connection

Please note: Electrical connection should be carried out by an appropriately qualified person and in accordance with current wiring regulations.

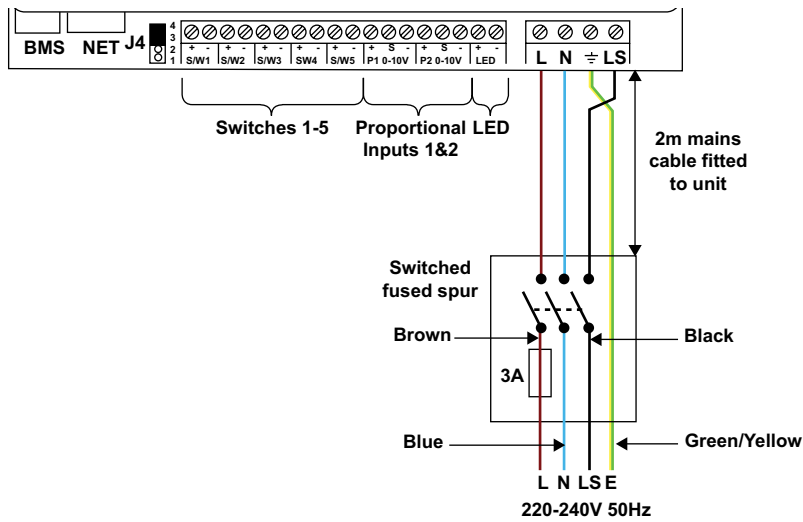

Trickle to Boost by Trickle/Boost Switch

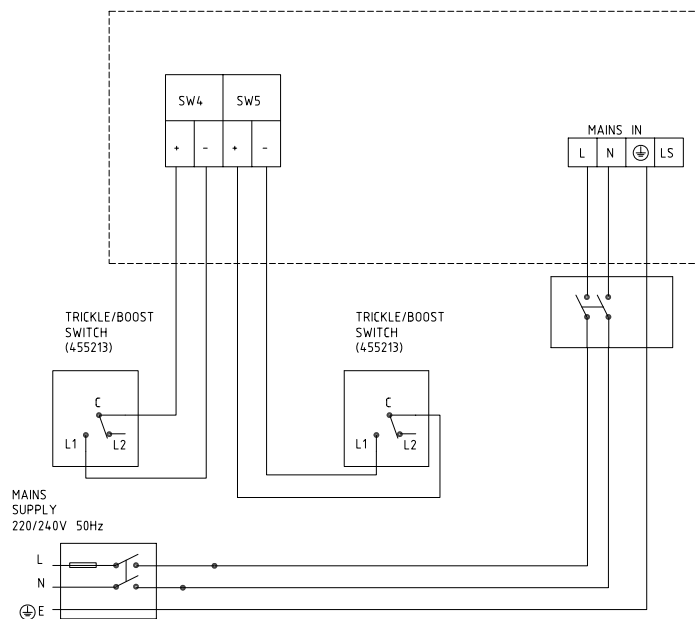

Lo-Carbon Sentinel Kinetic Plus

- Acoustic Enclosure option for reduced breakout noise
- Acoustic Top Box option for reduced in-duct noise
- Recognised in SAP PCDB
- Horizontal duct option for space-saving installations
- High airflow, ideal for student accommodation clusters
- Unique folding filter for removal when access is restricted
- Integrated digital controller for simple and accurate commissioning
- Lightweight for easy installation
- Plug and play controls; Humidistat, Wireless Remote
- BMS connectivity
- LS inputs (Light Switch)
- Volt-free inputs
- Self diagnosis for simplified fault finding
- Adjustable delay On/delay Off timer



Increased Performance

The Sentinel Kinetic Plus benefits from the latest high efficiency, backward curved impeller design, ensuring the lowest possible energy consumption, ultra quiet operation and an exceptional performance range covering small one bed apartments to the largest of houses.

For scenarios where noise is a critical issue, an Acoustic Enclosure is available to reduce breakout noise and the Acoustic Top Box will reduce in-duct noise at key frequencies.

Care Homes & Student Accommodation

The Sentinel Kinetic Plus is ideal for larger homes and multiple occupancy units such as care homes and student accommodation. Capable of 400m³/hr at 150Pa, the unit can extract from up to ten bathrooms and a communal kitchen while still achieving almost 90% heat recovery. The fully automatic capability of the Kinetic range means that adequate ventilation is always achieved.

The Kinetic's BMS capability is also ideal for those commercial applications where landlords or property managers want to monitor and optimise building performance and maintenance. The Kinetic BMS can provide status information and its self diagnostics can report if any fault is found.

Spigot Options

Spigots may be re-positioned to give horizontal connection or a combination of vertical and horizontal connection.

Optional 180mm/200mm spigots can simplify connection in commercial installations where larger diameter duct work has been used.

Quick Change Filter

As many systems are placed within cupboards the unique filter design folds as you remove it to ensure easy access in restricted spaces.

Integral Humidity Sensor

The integral humidity sensor increases speed in proportion to relative humidity levels, saving energy and reducing noise. The sensor also reacts to small but rapid increases in humidity, even if the normal trigger threshold is not reached. This unique feature ensures adequate ventilation, even for the smallest wet room. The night time relative humidity setback feature suppresses nuisance tripping as humidity gradually increases with falling temperature.

Models

Model	Stock Ref
Sentinel Kinetic Plus BS	447938
Sentinel Kinetic Plus Right	443028
Sentinel Kinetic Plus Right with Acoustic Top Box & Enclosure	479538
Sentinel Kinetic Plus Right with Acoustic Top Box	479537
Sentinel Kinetic Plus Right with Acoustic Enclosure	479536
Sentinel Kinetic Plus Left	443028L
Sentinel Kinetic Plus Left with Acoustic Top Box & Enclosure	479541
Sentinel Kinetic Plus Left with Acoustic Top Box	479540
Sentinel Kinetic Plus Left with Acoustic Enclosure	479539

Accessories

Model	Stock Ref
Wired Remote Controller	443283
LED Alarm with 15m cable	448356
Opto-coupler for volt-free BMS connection	447340
ISO 45% Coarse (G3) 2x Filter	403702
ISO ePM10 50% Pollen (M5) 1x Filter	444201
180mm/200mm Spigot Kit (One per pack)	446523
Anti Vibration Mounts	68MP033G
Acoustic Purge Fan	477988
Acoustic Purge Fan XL	479829

SAP PCDB Test Results (Kinetic Plus BS)

	SAP 2009		SAP 2012	
	Thermal Efficiency %	SFP (W/l/s)	Thermal Efficiency %	SFP (W/l/s)
K+1	91	0.51	91	0.42
K+2	91	0.40	91	0.44
K+3	90	0.41	90	0.52
K+4	90	0.45	90	0.63
K+5	90	0.53	90	0.76
K+6	90	0.60	91	0.90
K+7	90	0.70	91	1.05

SEC Class

Model	SEC Class
Kinetic Plus	A+

Dimensions (mm)

Unit

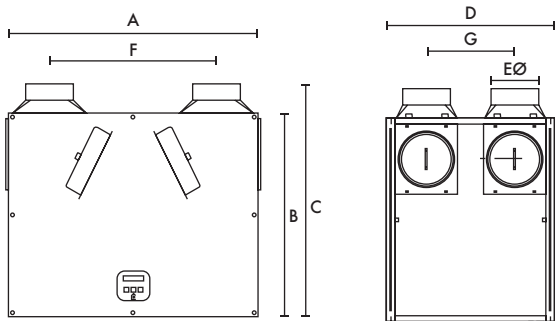

A	B	C	D	EØ	F	G
785	635	722	550	150	520	275

Weight: 24kg

Performance

Fan speeds are fully adjustable within the performance range.

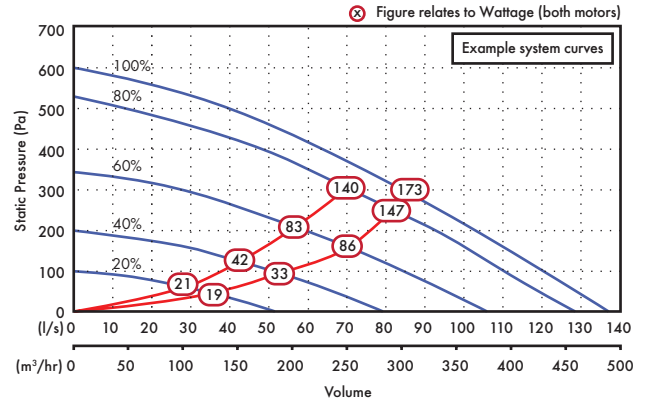

Acoustic Solution

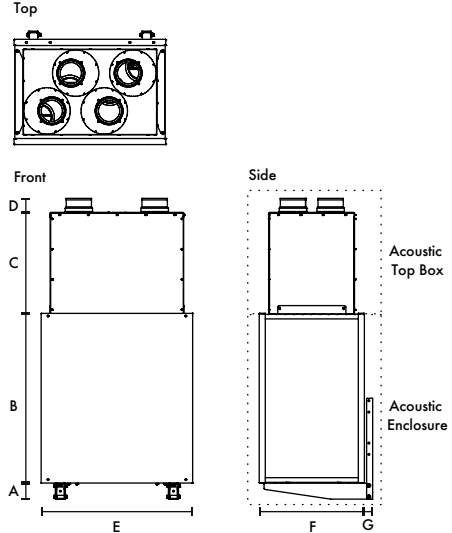

A	B	C	D	E	F	G	kg	kg	Spigot
80	733	501	71	855	583	40	17	33	150

Sound Data (Unit only)

Unit setting	Test mode	Octave band, Hz, dB SWL										SPL dB(A) at 3m
		63	125	250	500	1k	2k	4k	8k	LwA		
20%	Supply	54.4	60.9	50.6	45.9	34.3	23.6	19.1	24.5	51.3	30.8	
	Extract	48.4	56.7	43.7	35.9	21.4	16	18.7	24.5	42.3	24.8	
	Breakout	42.6	40.2	39.6	38	31.1	24.3	19.4	24.6	35.1	17.6	
40%	Supply	61.6	64.6	58.4	55.5	45.9	37.2	24.7	25.1	58.8	38.3	
	Extract	54.9	62.2	51.5	44.8	32.1	24.1	19.7	24.6	48.8	31.3	
	Breakout	51.1	49.3	48.9	45.9	41.3	35.7	26.7	25.6	44.0	26.5	
60%	Supply	67.5	67.5	73.2	62.4	53.4	47.5	33.5	28.3	69.2	48.7	
	Extract	62.5	61.7	60.1	51.1	39.2	32.1	23.2	24.8	54.0	36.5	
	Breakout	54.9	53	58.4	55.1	49.7	43.9	35.4	31.9	52.8	35.3	
80%	Supply	70.5	71.1	73.8	66.5	58.3	53.2	39.7	33.3	71.3	50.8	
	Extract	68.4	65.9	71.8	55.6	43.6	37.1	27.3	25.5	63.8	46.3	
	Breakout	59.2	56.8	63.6	57.3	54.2	49	41	37.5	56.8	39.3	
100%	Supply	72.8	73.1	75.2	70.4	61.6	56.6	44.2	37.6	73.9	53.4	
	Extract	71.7	69	71.8	57.4	45.7	39.9	30.9	26.6	64.1	46.6	
	Breakout	61.2	58.8	67.9	59.6	56.7	52.2	44.4	41.2	60.1	42.6	

Sound Data (Unit with Acoustic Solution)

Unit setting	Test mode	Octave band, Hz, dB SWL										SPL dB(A) at 3m
		63	125	250	500	1k	2k	4k	8k	LwA		
20%	Supply	55.7	49.2	36.6	23.6	17.4	14.9	17.8	23.3	36.1	18.6	
	Extract	51.4	42.4	30.3	20.9	16.8	14.9	17.8	23.3	30.8	13.3	
	Breakout	37.4	39.7	30.0	22.7	15.6	14.0	17.9	23.3	28.4	7.9	
40%	Supply	59.7	59.7	45.5	32.2	22.2	15.2	17.9	23.3	45.1	27.6	
	Extract	54.8	55.0	38.0	26.8	18.1	14.9	17.8	23.3	40.2	22.7	
	Breakout	45.7	48.5	39.9	32.8	24.2	17.5	18.0	23.4	36.8	16.3	
60%	Supply	66.1	61.9	53.6	41.0	29.8	18.3	18.0	23.3	49.5	32.0	
	Extract	60.6	55.9	48.4	34.9	23.8	16.3	17.9	23.3	43.8	26.3	
	Breakout	51.1	51.0	52.4	40.9	33.2	26.1	19.7	23.4	44.5	24.0	
80%	Supply	70.0	67.6	68.5	48.1	37.9	25.3	19.4	23.6	60.7	43.2	
	Extract	65.4	59.7	57.2	41.6	31.3	21.8	19.2	23.4	50.4	32.9	
	Breakout	55.6	55.6	57.9	47.9	40.4	34.3	26.1	23.7	51.3	30.8	
100%	Supply	72.1	70.1	66.4	51.6	41.9	29.7	21.7	24.0	60.0	42.5	
	Extract	68.2	62.4	60.6	45.5	36.0	26.6	21.7	23.6	53.8	36.3	
	Breakout	57.6	58.8	63.3	51.0	44.2	38.5	31.0	24.9	56.3	35.8	

Tested according to BS EN 13141-7:2010. Breakout quoted spherical. Supply and Extract quoted hemispherical. For in-duct data, end reflections are added based on the spigot size of the unit.

Consultant's Specification

Operation

The supply and extract ventilation unit shall be as Sentinel Kinetic Plus as manufactured by Vent-Axia and shall be sized as indicated on the drawings and shall be in accordance with the particular specification.

Supply air to the room shall be pre-heated by the extract air via the integrated composite plastic counterflow heat recovery cell. The Sentinel Kinetic Plus shall automatically vary the ventilation rate via EC/DC motors, as it receives signals from one of the optional interconnected sensors.

When a signal is received, the fans shall either vary their speed proportionally or on a trickle and boost principle.

The unit shall have the facility to commission the supply and extract fans individually via in-built minimum and maximum speed adjustment, or alternative wired remote control unit. The fans themselves shall have independent, infinitely variable speed control.

Unit Specification

The unit shall be manufactured with an ABS outer case construction, and incorporate a reversible core to allow for left or right hand mounting.

The unit shall have a high efficiency composite plastic counterflow heat exchanger, supply and extract filters, automatic summer bypass, integral minimum and maximum infinitely variable speed controls with fascia mounted failure indication.

The unit shall have low energy, high efficiency EC/DC fan/motor assemblies with sealed for life bearings. The impellers shall be high efficiency backward curved centrifugal type.

The unit shall have a heat exchanger cell with a thermal efficiency of up to 92% when tested to EN 308. This shall be protected by ISO 45% Coarse (G3) grade synthetic filters on supply and extract. Complete with a condensate drip tray and drain connection.

To reduce breakout noise, the MVHR unit shall be provided with an Acoustic Enclosure of steel construction lined with class '0' acoustic foam. To reduce in-duct noise, the top of the MVHR shall be fitted with an Acoustic Top Box to provide attenuation to the 4 ducts of the unit. This Acoustic Top Box shall be of steel construction lined with acoustic class '0' foam with the MVHR spigots linked to the Top Box via 4 separate attenuated ducts. The acoustic enclosure and top box shall each be independently tested for noise to BS EN 13141-7.

The unit shall be constructed with a removable Core allowing full maintenance access. The removable Core shall provide access to the following:

- ✓ Supply and extract filter
- ✓ Heat exchanger
- ✓ Access to the electrical connections

Access shall be provided for wiring termination and setup/commissioning. The backlit LCD user interface therein may be duplicated for remote mounting if required.

Units shall be as manufactured by Vent-Axia Ltd.

The MVHR unit shall incorporate an Expanded Polystyrene (EPS) inner chassis with custom motor and impeller mounting features. The inner chassis will assist in reducing noise and act as a large anti-vibration mount to avoid transmission through to the back mounting plate or the base of the unit.

The MVHR unit shall be tested to ensure it meets the maximum allowable vibration of no more than 1 mm/s, measured on the unit wall fixing points.

Sound tested to BS EN 13141-7:2010

Standard Controls

All Sentinel Kinetic units shall incorporate the following functions integrally mounted, pre-wired and factory fitted by the manufacturer:

- ✓ Integral infinitely variable fan speed control on supply and extract
- ✓ Integral min/max ventilation control/set point
- ✓ Integral BMS input/output interfaces - control and status indication
- ✓ Heating interlocks
- ✓ 0-10V proportional speed adjustment
- ✓ Volt free contacts
- ✓ 24V sensor supply
- ✓ Integral on/off or trickle boost function from remote switch, e.g. PIR occupancy detector
- ✓ Fully automatic summer bypass
- ✓ Switched Live input with adjustable 'delay-on' feature
- ✓ Fan failure or component failure indicated via individual fault code display
- ✓ Running time counter
- ✓ Control panel PIN number lock
- ✓ Automatic frost protection effective to -20°C
- ✓ The unit shall incorporate an integral humidity sensor with the following features:
 - Ambient Response; Raises the humidity trigger point as dwelling temperature reduces
 - Rapid Response: Monitors the rate of change in humidity and triggers increased airflow even if the humidity trigger threshold is not reached
 - Proportional Response; Incrementally increases the fan speed to reduce noise and reduce energy consumption
- ✓ The unit shall be controlled by the 'Sentinel' control devices (enablers and sensors) as detailed in the schedule or on the drawings.
- ✓ Tool free filter access

Mounting Option

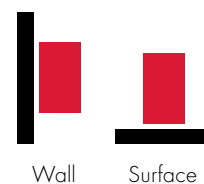

Airflow Direction

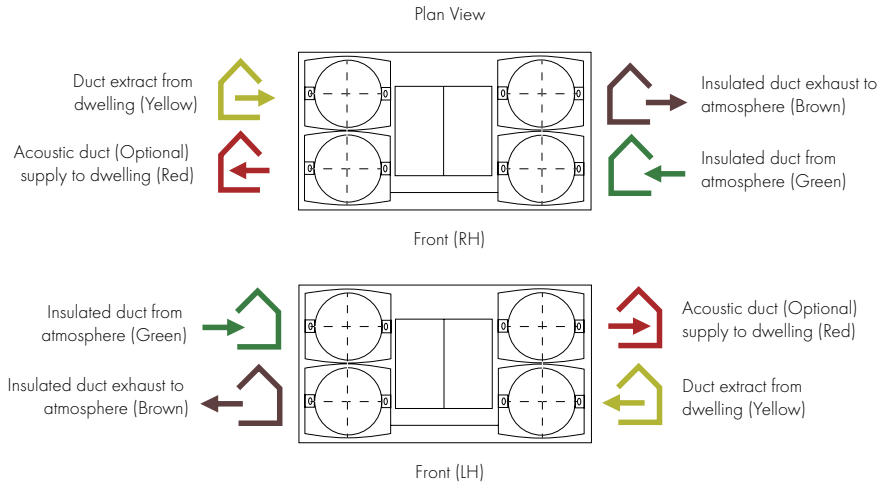

Electrical Connection

Please note: Electrical connection should be carried out by an appropriately qualified person and in accordance with current wiring regulations.

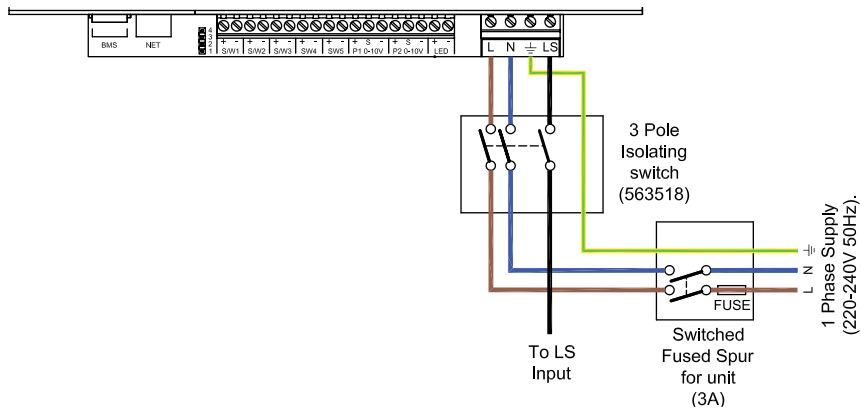

Trickle to Boost by two lighting circuits or Trickle/Boost Switch

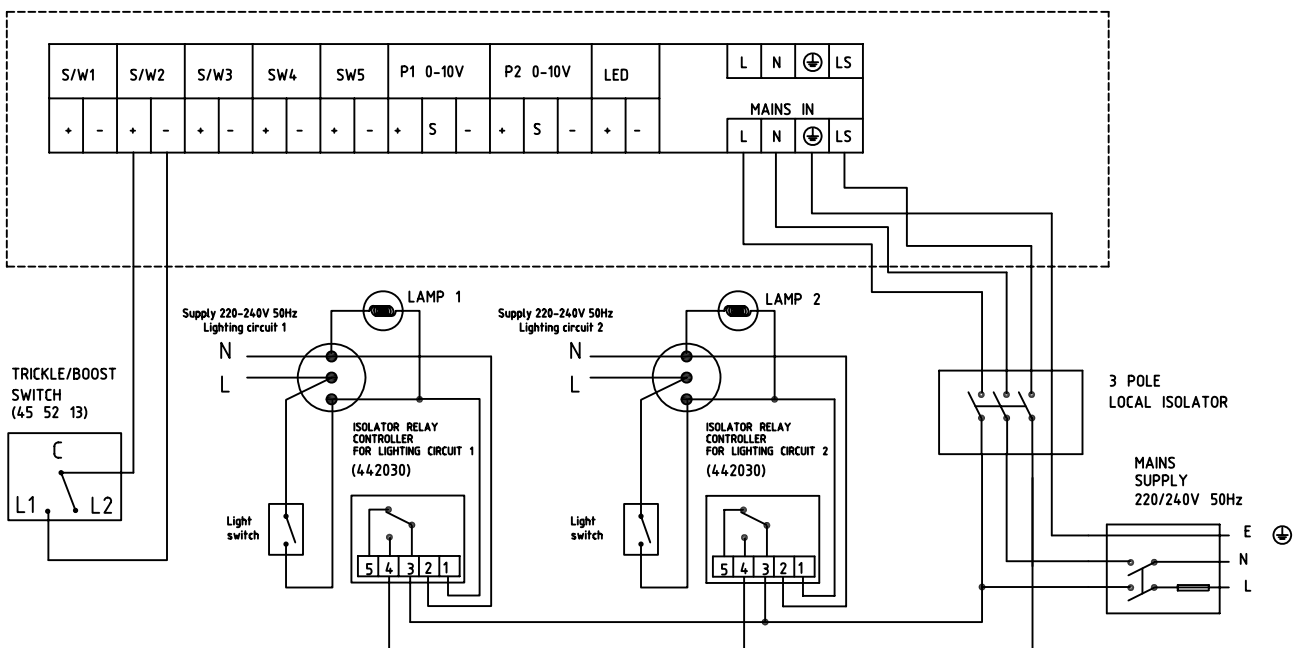

Lo-Carbon Sentinel Kinetic High Flow

- Acoustic Enclosure option for reduced breakout noise
- Acoustic Top Box option for reduced in-duct noise
- Recognised in SAP PCDB
- 180mm/200mm spigots
- Horizontal duct option for space-saving installations
- High airflow, ideal for student accommodation clusters
- Unique folding filter for removal when access is restricted
- Integrated digital controller for simple and accurate commissioning
- Plug and play controls; Humidistat, Wireless Remote
- BMS connectivity
- LS inputs (Light Switch)
- Volt-free inputs



Increased Performance

The Sentinel Kinetic High Flow benefits from the latest high efficiency, backward curved impeller design, ensuring the lowest possible energy consumption, and an exceptional performance range covering small one bed apartments to the largest of houses.

For scenarios where noise is a critical issue, an Acoustic Enclosure is available to reduce breakout noise and the Acoustic Top Box will reduce in-duct noise at key frequencies.

Care Homes & Student Accommodation

The Sentinel Kinetic High Flow is ideal for larger homes and multiple occupancy units such as care homes and student accommodation. Capable of 175l/s at 150Pa, the unit can extract from up to fourteen bathrooms and a communal kitchen while still achieving almost 90% heat recovery. The fully automatic capability of the Kinetic range means that adequate ventilation is always achieved.

The Kinetic's BMS capability is also ideal for those commercial applications where landlords or property managers want to monitor and optimise building performance and maintenance. The Kinetic BMS can provide status information and its self diagnostics can report if any fault is found.

Spigot Options

180mm/200mm Spigots may be re-positioned to give horizontal connection or a combination of vertical and horizontal connection.

Quick Change Filter

As many systems are placed within cupboards the unique filter design folds as you remove it to ensure easy access in restricted spaces.

Integral Humidity Sensor

The integral humidity sensor increases speed in proportion to relative humidity levels, saving energy and reducing noise. The sensor also reacts to small but rapid increases in humidity, even if the normal trigger threshold is not reached. This unique feature ensures adequate ventilation, even for the smallest wet room. The night time relative humidity setback feature suppresses nuisance tripping as humidity gradually increases with falling temperature.

Models

Model	Stock Ref
Kinetic High Flow Right	408449
Kinetic High Flow Right with Acoustic Top Box & Enclosure	479544
Kinetic High Flow Right with Acoustic Top Box	479543
Kinetic High Flow Right with Acoustic Enclosure	479542
Kinetic High Flow Left	408451
Kinetic High Flow Left with Acoustic Top Box & Enclosure	479547
Kinetic High Flow Left with Acoustic Top Box	479546
Kinetic High Flow Left with Acoustic Enclosure	479545

For further details, see Sentinel Kinetic Plus.

Accessories

Model	Stock Ref
Wired Remote Controller	443283
LED Alarm with 15m cable	448356
Opto-coupler for volt-free bms connection	447340
ISO 45% Coarse (G3) 2x Filter	403702
ISO ePM10 50% Pollen (M5) 1x Filter	444201
Anti Vibration Mounts	68MP033G
Acoustic Purge Fan	477988
Acoustic Purge Fan XL	479829

SAP PCDB Test Results

	SAP 2009		SAP 2012	
	Thermal Efficiency %	SFP (W/l/s)	Thermal Efficiency %	SFP (W/l/s)
K + 1	88	0.65	88	0.58
K + 2	88	0.54	90	0.55
K + 3	90	0.52	91	0.60
K + 4	90	0.55	91	0.69
K + 5	91	0.6	90	0.78
K + 6	91	0.66	90	0.92
K + 7	90	0.74	90	1.09

SEC Rating

Model	SEC Class
Kinetic High Flow	A

Dimensions (mm)

Unit

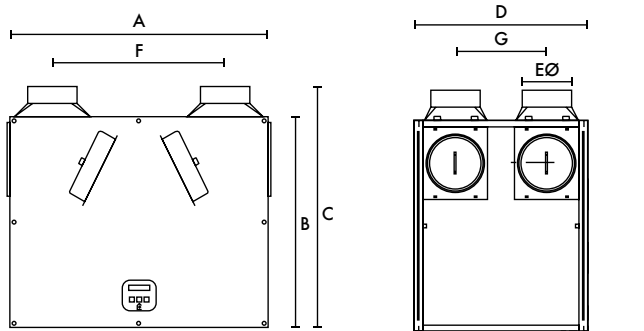

A	B	C	D	EØ	F	G
785	635	722	550	180/200	520	275

Weight: 31kg

Performance

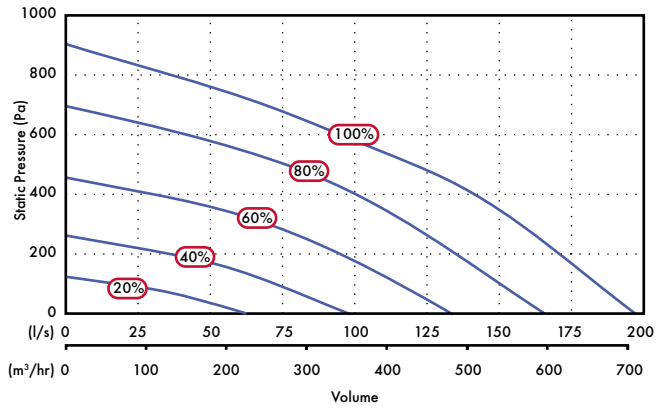

Acoustic Solution

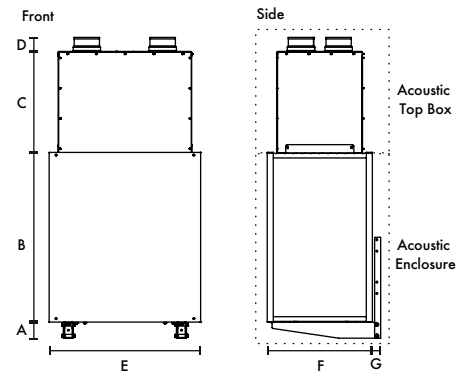

A	B	C	D	E	F	G	kg	kg	Spigot
80	733	501	71	855	583	40	17	33	180

Sound Data (Unit only)

Flow %	Test Mode	Octave band, Hz, dB SWL								SPL dB(A)	
		63	125	250	500	1K	2K	4K	8K	LwA	@ 3m
20	Supply	55.1	65.9	55.2	53.8	44.4	37.4	25.3	24.9	66.8	34.1
	Extract	58.2	57.4	48.0	45.6	43.8	34.5	20.0	24.5	61.3	27.9
	Breakout	43.3	46.6	44.9	44.7	41.8	30.4	21.6	22.5	51.6	25.1
40	Supply	63.1	69.0	67.1	64.0	55.0	51.6	39.7	32.4	64.2	43.7
	Extract	58.6	58.4	60.0	53.7	41.9	41.5	31.7	25.1	54.9	34.3
	Breakout	55.4	49.6	60.6	53.8	46.5	41.5	33.2	27.4	55.4	34.8
60	Supply	70.3	74.3	81.4	71.5	63.6	59.9	49.6	43.1	74.8	54.3
	Extract	64.4	64.2	72.6	59.1	48.7	45.7	37.8	29.3	64.9	44.4
	Breakout	62.8	54.6	65.7	57.2	55.5	49.2	41.4	36.4	61.0	40.5
80	Supply	75.3	77.9	88.1	78.7	68.4	65.1	56.0	50.1	81.4	60.9
	Extract	71.1	68.2	73.6	61.8	51.9	49.5	42.7	37.6	66.4	45.9
	Breakout	66.2	59.0	73.4	61.8	57.0	54.6	47.3	43.1	66.8	46.2
100	Supply	90.9	80.9	84.4	80.1	71.5	68.0	59.3	54.5	80.7	60.1
	Extract	92.4	71.8	78.1	67.4	54.9	51.5	44.6	41.4	72.2	51.7
	Breakout	69.3	62.9	74.9	67.5	59.2	56.6	49.1	44.7	69.3	48.8

Tested according to BS EN 13141-7:2010. Breakout quoted spherical. Supply and Extract quoted hemispherical.

Sound Data (Unit with Acoustic Enclosure)

Flow %	Test Mode	Octave band, Hz, dB SWL								SPL dB(A)	
		63	125	250	500	1K	2K	4K	8K	LwA	@ 3m
20	Supply	55.2	57.0	46.1	38.8	24.0	15.4	18.0	23.2	43.6	26.1
	Extract	50.4	53.6	37.0	32.3	18.2	15.1	18.0	23.2	38.7	21.2
	Breakout	41.3	51.8	39.2	32.3	20.5	15.8	18.1	23.2	37.7	17.2
40	Supply	64.1	59.6	59.7	51.9	35.5	22.8	19.9	23.5	53.3	35.8
	Extract	56.6	50.7	49.0	41.9	24.5	17.7	18.1	23.2	43.3	25.8
	Breakout	46.7	50.5	53.0	44.8	32.2	22.2	18.5	23.3	45.6	25.1
60	Supply	67.3	64.0	67.7	58.6	43.2	30.6	26.5	25.9	61.0	43.5
	Extract	61.6	56.7	55.5	49.0	32.2	25.3	19.7	23.4	50.2	32.7
	Breakout	53.0	54.4	60.2	48.8	40.6	33.2	23.4	23.4	53.0	32.5
80	Supply	70.3	67.7	74.6	61.8	48.5	36.2	33.0	31.4	67.5	50.0
	Extract	66.7	60.0	67.2	50.9	38.1	32.8	24.0	24.1	59.7	42.2
	Breakout	58.0	58.0	64.7	52.4	45.7	39.9	31.2	24.3	58.7	38.2
100	Supply	73.0	70.1	77.1	65.1	51.4	39.5	37.0	36.4	70.1	52.6
	Extract	69.6	62.5	67.3	56.2	41.7	37.0	28.1	25.3	60.5	43.0
	Breakout	61.0	61.2	65.9	57.7	48.5	43.8	36.3	26.3	60.7	40.2

Consultant's Specification

Operation

The supply and extract ventilation unit shall be as Sentinel Kinetic High Flow as manufactured by Vent-Axia and shall be sized as indicated on the drawings and shall be in accordance with the particular specification.

Supply air to the room shall be pre-heated by the extract air via the integrated composite plastic counterflow heat recovery cell. The Sentinel Kinetic High Flow shall automatically vary the ventilation rate via EC/DC motors, as it receives signals from one of the optional interconnected sensors.

When a signal is received, the fans shall either vary their speed proportionally or on a trickle and boost principle.

The unit shall have the facility to commission the supply and extract fans individually via in-built minimum and maximum speed adjustment, or alternative wired remote control unit. The fans themselves shall have independent, infinitely variable speed control.

Unit Specification

The unit shall be manufactured with an ABS outer case construction, and incorporate a reversible core to allow for left or right hand mounting.

The unit shall have a high efficiency composite plastic counterflow heat exchanger, supply and extract filters, automatic summer bypass, integral minimum and maximum infinitely variable speed controls with fascia mounted failure indication.

The unit shall have low energy, high efficiency EC/DC fan/motor assemblies with sealed for life bearings. The impellers shall be high efficiency backward curved centrifugal type.

The unit shall have a heat exchanger cell with a thermal efficiency of up to 92% when tested to EN 308. This shall be protected by ISO 45% Coarse (G3) grade synthetic filters on supply and extract. Complete with a condensate drip tray and drain connection.

To reduce breakout noise, the MVHR unit shall be provided with an Acoustic Enclosure of steel construction lined with class 'O' acoustic foam. To reduce in-duct noise, the top of the MVHR shall be fitted with an Acoustic Top Box to provide attenuation to the 4 ducts of the unit. This Acoustic Top Box shall be of steel construction lined with acoustic class 'O' foam with the MVHR spigots linked to the Top Box via 4 separate attenuated ducts. The acoustic enclosure and top box shall each be independently tested for noise to BS EN 13141-7.

The unit shall be constructed with a removable Core allowing full maintenance access. The removable Core shall provide access to the following:

- ✓ Supply and extract filter
- ✓ Heat exchanger
- ✓ Access to the electrical connections

Access shall be provided for wiring termination and setup/commissioning. The backlit LCD user interface therein may be duplicated for remote mounting if required.

Units shall be as manufactured by Vent-Axia Ltd.

The MVHR unit shall incorporate an Expanded Polystyrene (EPS) inner chassis with custom motor and impeller mounting features. The inner chassis will assist in reducing noise and act as a large anti-vibration mount to avoid transmission through to the back mounting plate or the base of the unit.

The MVHR unit shall be tested to ensure it meets the maximum allowable vibration of no more than 1 mm/s, measured on the unit wall fixing points.

Sound tested to BS EN 13141-7:2010

Standard Controls

All Sentinel Kinetic units shall incorporate the following functions integrally mounted, pre-wired and factory fitted by the manufacturer:

- ✓ Integral infinitely variable fan speed control on supply and extract
- ✓ Integral min/max ventilation control/set point
- ✓ Integral BMS input/output interfaces - control and status indication
- ✓ Heating interlocks
- ✓ 0-10V proportional speed adjustment
- ✓ Volt free contacts
- ✓ 24V sensor supply
- ✓ Integral on/off or trickle boost function from remote switch, e.g. PIR occupancy detector
- ✓ Fully automatic summer bypass
- ✓ Switched Live input with adjustable 'delay-on' feature
- ✓ Fan failure or component failure indicated via individual fault code display
- ✓ Running time counter
- ✓ Control panel PIN number lock
- ✓ Automatic frost protection effective to -20°C
- ✓ The unit shall incorporate an integral humidity sensor with the following features:
 - Ambient Response; Raises the humidity trigger point as dwelling temperature reduces
 - Rapid Response: Monitors the rate of change in humidity and triggers increased airflow even if the humidity trigger threshold is not reached
 - Proportional Response; Incrementally increases the fan speed to reduce noise and reduce energy consumption
- ✓ The unit shall be controlled by the 'Sentinel' control devices (enablers and sensors) as detailed in the schedule or on the drawings.
- ✓ Tool free filter access

Mounting Option

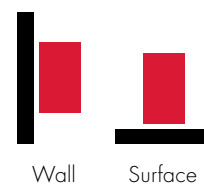

Airflow Direction

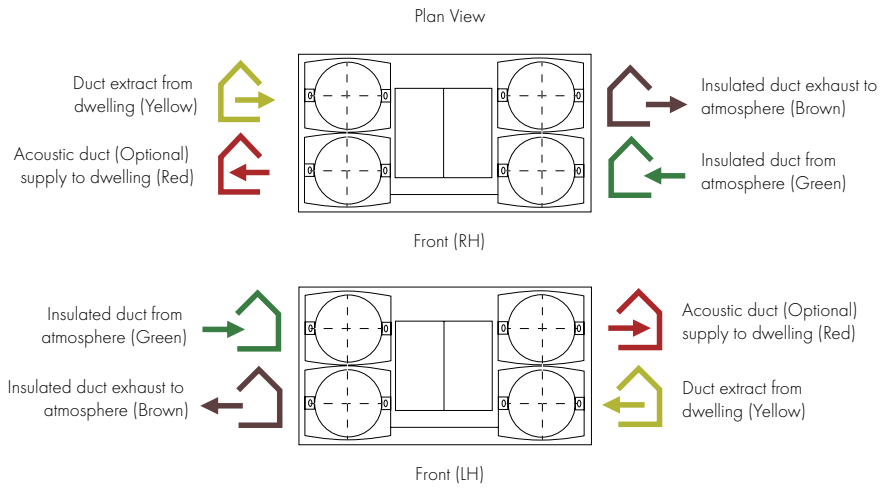

Electrical Connection

Please note: Electrical connection should be carried out by an appropriately qualified person and in accordance with current wiring regulations.

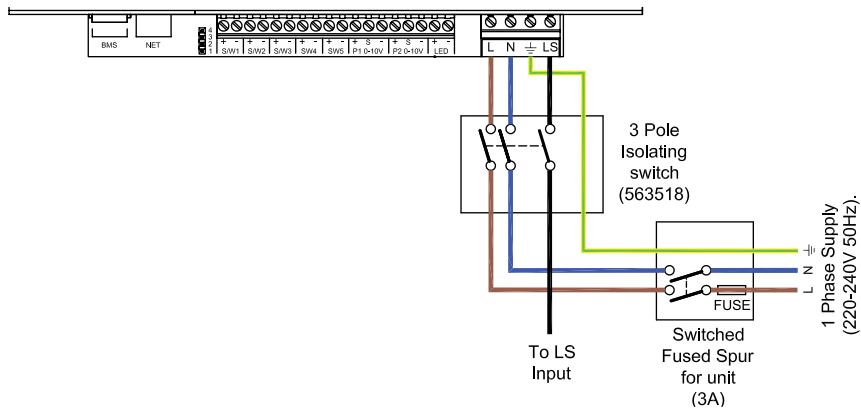

Trickle to Boost by two lighting circuits or Trickle/Boost Switch

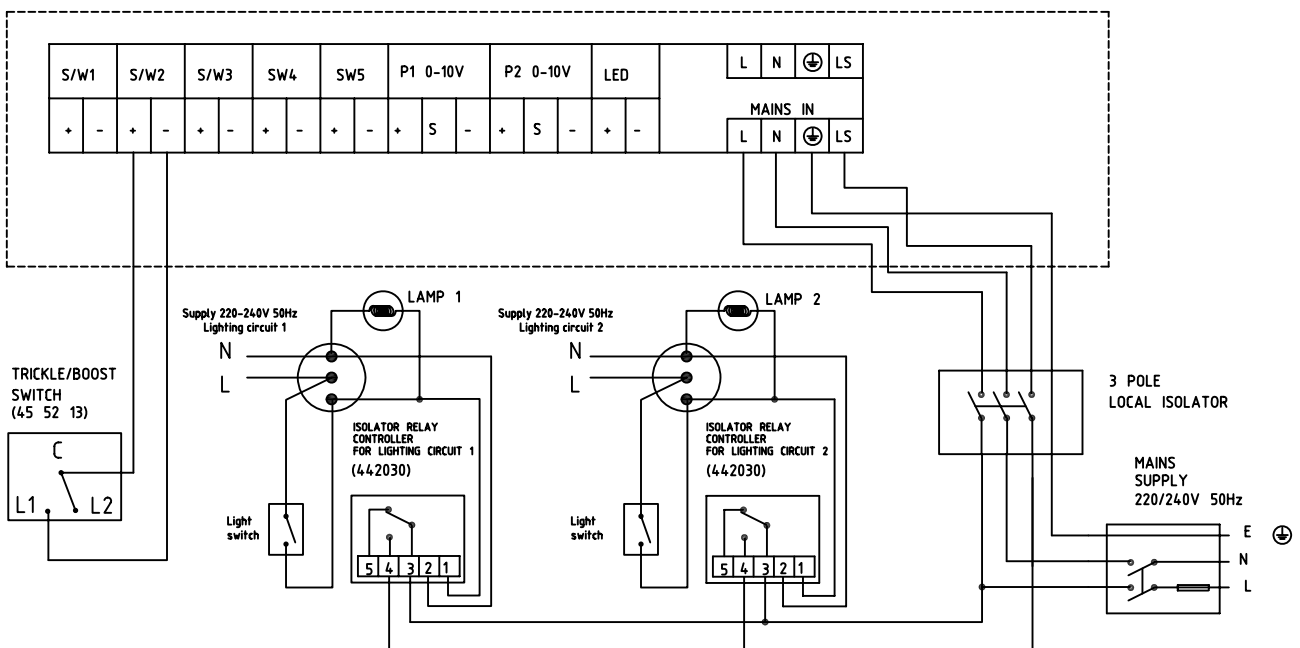

Lo-Carbon Sentinel Kinetic Cooker Hood

- Acoustic Top Box option for reduced in-duct noise
- Recognised in SAP PCDB
- Includes Cooker Hood Canopy
- Horizontal duct option for space-saving installations
- Fits within a 600mm wide aperture (300mm deep)
- Integrated digital controller for simple and accurate commissioning
- Plug and play controls; Humidistat, Wireless Remote
- BMS connectivity
- LS inputs (Light Switch)
- Volt-free inputs
- Self diagnosis for simplified fault finding
- Adjustable delay On/delay Off timer



Easy Installation

Ducting can be attached to the unit horizontally, vertically or both. Minimum internal depth of kitchen cupboard: 300mm.

Horizontal and Vertical Spigots: The combination of spigot options allows installation in confined locations. If vertical and horizontal connection are required on the same outlet/inlet, additional spigots can be supplied.

The condensate connection can be taken through the rear of the unit or through the side of the unit into an adjacent cupboard prior to connection into pre-installed domestic waste water system.

Cooker Hood Unit

The Sentinel Kinetic Cooker Hood is designed to fit in a 600mm wide aperture above a hob. The telescopic hood incorporates two flat removable metal grease filters, low energy light bulbs and is available with a White or Brushed Aluminium front trim.

The hood contains an integral fire damper in accordance with BRE Digest 398 and is connected to the heat recovery unit by a galvanised steel duct with access for cleaning. When the hood is opened, the heat recovery unit goes to boost speed and the summer bypass automatically opens to prevent cooking by-products entering the heat recovery cell. As an additional safety feature, the duct also contains a thermal cut-out fuse which turns off the MVHR unit in the event of excessive temperature in the airway. Cooker Hood units cannot be handed on-site and must be purchased as left hand (L) or right hand (R) models.

SELV Models

SELV cooker hoods allow the distance between the hood and an electric hob to be reduced from 650mm to 550mm.

Integral Humidity Sensor

The integral humidity (models with H suffix) sensor increases speed in proportion to relative humidity levels, saving energy and reducing noise. The sensor also reacts to small but rapid increases in humidity, even if

the normal trigger threshold is not reached. This unique feature ensures adequate ventilation, even for the smallest wet room. The night time relative humidity setback feature suppresses nuisance tripping as humidity gradually increases with falling temperature.

Models

Lo-Carbon Sentinel Kinetic with summer bypass and humidity sensor.

Model	Stock Ref
Kinetic CWH L (White Left)	446756
Kinetic CSH L (Brushed Aluminium Left)	446757
Kinetic CWH R (White Right)	446758
Kinetic CSH R (Brushed Aluminium Right)	446759
Kinetic CWH L SELV (White Left)	477003
Kinetic CSH L SELV (Brushed Aluminium Left)	477004
Kinetic CWH R SELV (White Right)	477005
Kinetic CSH R SELV (Brushed Aluminium Right)	477006

Accessories

Model	Stock Ref
Wired Remote Controller	443283
LED Alarm with 15m cable	448356
Opto-coupler for volt-free bms connection	447340
ISO 45% Coarse (G3) 2x Filter	442356
ISO ePM10 50% Pollen (M5) 1x Filter	444199
Grease 2x Filter	372774
Acoustic Purge Fan	477988
Acoustic Purge Fan XL	479829

SAP PCDB Test Results

	SAP 2009		SAP 2012	
	Thermal Efficiency %	SFP (W/l/s)	Thermal Efficiency %	SFP (W/l/s)
K+1	85	0.72	85	0.78
K+2	85	0.74	85	0.89
K+3	84	0.83	82	1.03
K+4	83	0.92		

SEC Class

Model	SEC Class
Kinetic CWH/CSH	A

Performance

Fan speeds are fully adjustable within the performance range.

Horizontal Spigots

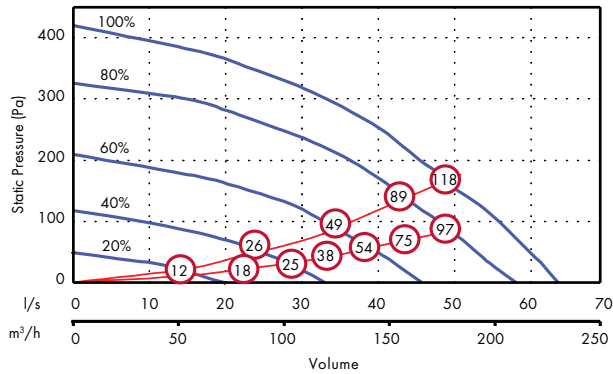

Vertical Spigots

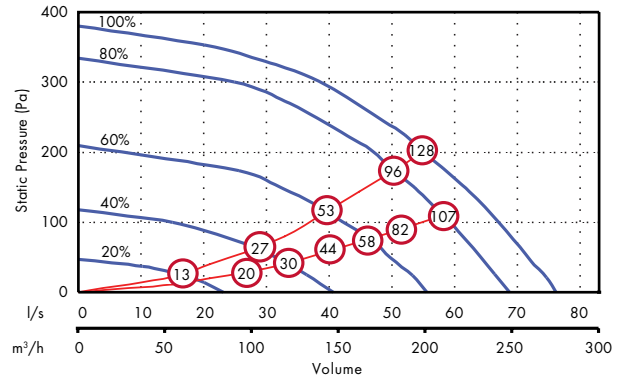

x figure relates to Wattage (both motors)

Dimensions (mm)

Unit

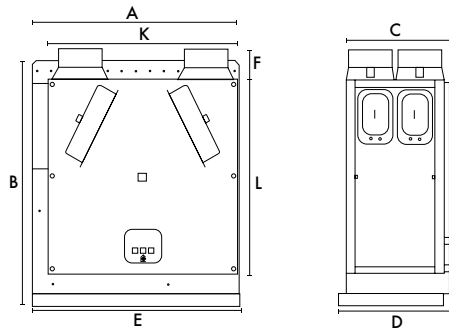

Minimum clearance from the bottom of this unit to the top of the hob must be:
 Gas: 750mm
 Electric: 650mm/ 550mm (SELV)

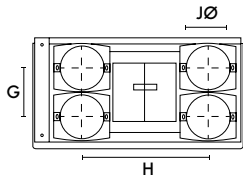

A	B	C	D	E	F	G	H	JØ	K	L	kg
590	710	295	316	598	90	140	360	125	550	550	27

Sound Data

Flow l/s	Test mode	Octave band, Hz, dB SWL								SPL dB(A) @ 3m
		63	125	250	500	1K	2k	4K	8K	
10	Supply	47.8	40.2	38	31.1	28.2	22.1	23.6	30.9	21.4
	Extract	47	38.7	36	29.9	25	22.4	23.3	30.8	20.6
	Breakout	43.6	36.2	37.4	30.9	27.4	23.3	24.2	31.4	18.6
20	Supply	54	46.6	50.2	44.5	44.4	38.3	28.8	31.9	31.2
	Extract	46.8	40.5	34.6	34.2	34.6	25.9	23.7	30.3	22.9
	Breakout	45.9	39.9	40.6	35.7	33.5	28.4	25.3	31.2	21.3
30	Supply	58.1	54.5	57.6	52.2	51.7	47.6	38.6	35.8	38.5
	Extract	47.6	46.2	38.7	41.3	42.8	33.9	26.4	30.5	28.4
	Breakout	45.2	42.4	48.2	40.8	37.7	35.2	30	31.1	25.2
40	Supply	65.2	58.4	62.3	58	56.5	52.5	44.1	41.4	43.6
	Extract	53.5	53	44	47.7	48.1	39.7	31.5	31.5	33.5
	Breakout	50.9	47.6	47.4	48.1	42.5	40.8	36.3	34.4	29.3
50	Supply	66.4	63.2	66.3	62.5	61.7	57.4	50	47.8	48.3
	Extract	64.2	55.2	48	50.9	52.1	44.5	35.9	35	37.2
	Breakout	55	51	51.3	51.6	46.9	46.0	42	38.3	33.2

Tested according to BS EN 13141-7:2010. Breakout quoted spherical. Supply and Extract quoted hemispherical. For in-duct data, end reflections are added based on the spigot size of the unit.

Consultant's Specification

Operation

The supply and extract ventilation unit shall be a Sentinel Kinetic as manufactured by Vent-Axia and shall be sized as indicated on the drawings and shall be in accordance with the particular specification.

Supply air to the room shall be pre-heated by the extract air via the integrated composite plastic counterflow heat recovery cell. The Sentinel Kinetic shall automatically vary the ventilation rate via EC/DC motors, as it receives signals from one of the optional interconnected sensors. When a signal is received, the fans shall either vary their speed proportionally or on a trickle and boost principle.

The unit shall have the facility to commission the supply and extract fans individually via in-built minimum and maximum speed adjustment, or alternative wired remote control unit. The fans themselves shall have independent, infinitely variable speed control.

Unit Specification

The unit shall be manufactured with an ABS outer case construction, and incorporate a metal duct to the cooker hood, intumescent fire damper and thermal switch, in accordance with BRE Digest 398.

The unit shall have a high efficiency composite plastic counterflow heat exchanger, supply and extract filters, automatic summer bypass, integral minimum and maximum infinitely variable speed controls with fascia mounted failure indication. The unit shall have low energy, high efficiency EC/DC fan/motor assemblies with sealed for life bearings. The impellers shall be high efficiency forward curved centrifugal type.

The unit shall have a heat exchanger cell with a thermal efficiency of up to 92% when tested to EN 308. This shall be protected by ISO 45% Coarse (G3) Filter 2pk grade synthetic filters on supply and extract. Complete with a condensate drip tray and drain connection.

The unit shall be constructed with a removable Core allowing full maintenance access. The removable Core shall provide access to the following:

- ✓ Supply and extract filter
- ✓ Heat exchanger
- ✓ Access to the electrical connections

Access shall be provided for wiring termination and setup/commissioning. The backlit LCD user interface therein shall be removable for remote mounting if required.

Units shall be as manufactured by Vent-Axia Ltd.

Sound tested to BS EN 13141-7:2010

Standard Controls

All Sentinel Kinetic units shall incorporate the following functions integrally mounted, pre-wired and factory fitted by the manufacturer:

- ✓ Integral infinitely variable fan speed control on supply and extract
- ✓ Integral min/max ventilation control/set point
- ✓ Integral BMS interfaces - control and status indication
- ✓ Heating interlocks
- ✓ 0-10V proportional speed adjustment
- ✓ Volt free contacts
- ✓ 24V sensor supply
- ✓ Integral on/off or trickle boost function from remote switch e.g. PIR occupancy detector
- ✓ The unit shall be controlled by the 'Sentinel' control devices (enablers and sensors) as detailed in the schedule or on the drawings
- ✓ Fully automatic summer bypass
- ✓ Switched Live input with adjustable 'Delay-On' feature

- ✓ Fan failure or component failure indicated via individual fault code display
- ✓ Running time counter
- ✓ Control panel PIN number lock
- ✓ Automatic frost protection effective to -20°C
- ✓ Tool free filter access
- ✓ The unit shall incorporate ('H' models) an integral humidity sensor with the following features:
 - Ambient Response; Raises the humidity trigger point as dwelling temperature reduces
 - Rapid Response; Monitors the rate of change in humidity and triggers increased airflow even if the humidity trigger threshold is not reached
 - Proportional Response; Incrementally increases the fan speed to reduce noise and reduce energy consumption

Integral Cooker Hood Specification

The Sentinel Kinetic Cooker Hood shall consist of a telescopic Hood and galvanised steel duct connection to the MVHR Unit.

The Hood construction shall be of grey powder coated steel with Brushed Aluminium or White painted fascia.

The Hood shall trigger the MVHR unit to a pre-defined boost speed and open the summer bypass when opened, and shall have two low-energy lamps illuminating the hob top.

Filter shall be a flat metal grease filter, removable for cleaning.

The galvanised steel ductwork shall provide a continuous fire barrier between the Hood and the MVHR unit. It shall contain an Intumescent fire damper, thermal cut-out and volume balancing damper. The thermal cut-out shall switch off the MVHR unit at a pre-defined safety temperature.

The duct shall have an access panel for cleaning by the end-user.

Mounting Option



Airflow Direction

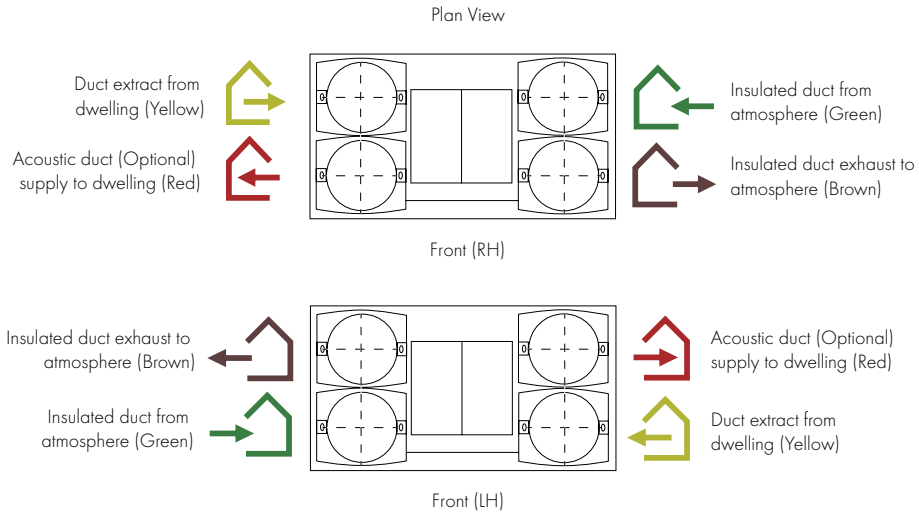

Electrical Connection

Please note: Electrical connection should be carried out by an appropriately qualified person and in accordance with current wiring regulations.

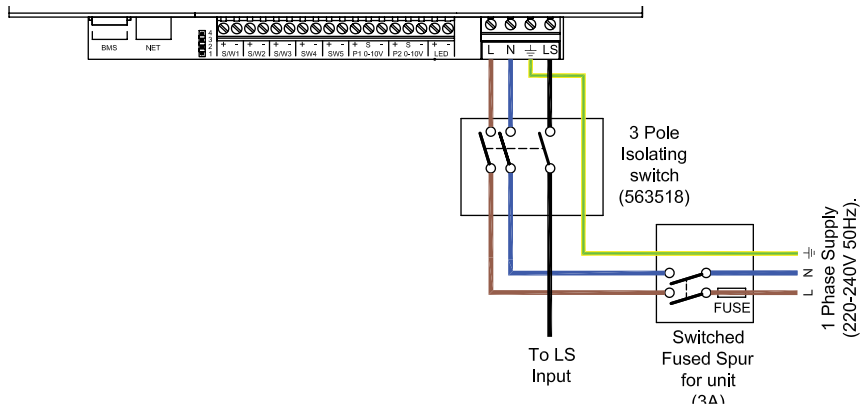

Trickle to Boost by a Light Circuit

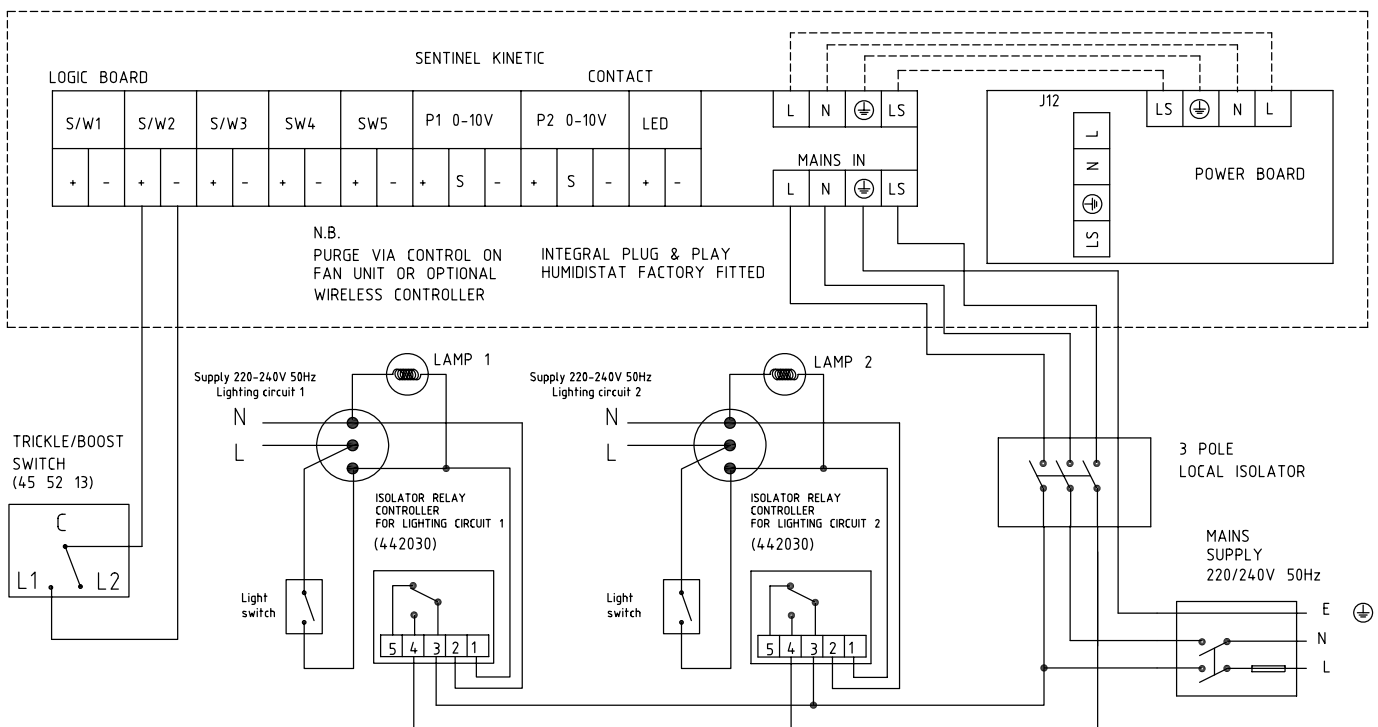

Lo-Carbon Sentinel Kinetic Horizontal

- Manufactured in the UK
- Building Regulations ADF compliant
- Recognised in SAP PCDB
- Energy Savings Trust best practice compliant
- Up to 81% heat recovery whilst controlling condensation
- Programmable Summer bypass
- Digital controller for simple and accurate commissioning
- External condensate connection
- Plug and play controls; Humidistat, Wireless remote
- LS inputs (Light Switch)
- Volt-free inputs
- Self diagnosis for simplified fault finding
- Adjustable delay On/delay Off timer

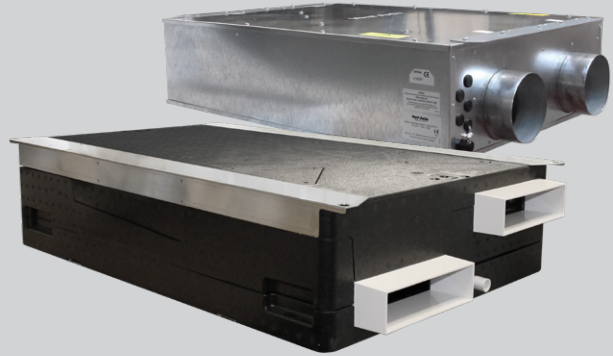

The Sentinel Kinetic Horizontal Range

A wholehouse heat recovery system with up to 81% heat exchange efficiency. An easily accessible heat recovery cube protected by two removable ISO 45% Coarse (G3) Filter 2pk. Two Lo-Carbon Energy Saving EC/DC fans ensure long life (typically over double the life of AC motors) and lowest possible energy use. Fully insulated construction with built-in condensation drain. Specifically designed for new build constructions with a high level of insulation.

Lo-Carbon Sentinel Kinetic Horizontal meets the latest requirements of the Building Regulations ADF for wholehouse system ventilation: Continuous mechanical supply and extract with heat recovery. Each model has three fully adjustable speeds and a purge setting (maximum flow). Supplied with the unit is a digital controller that can be used to pre-set the speeds to any required airflow within the performance range.

Integral Humidity Sensor

The integral humidity sensor ('H' models) increases speed in proportion to relative humidity levels, saving energy and reducing noise. The sensor also reacts to small but rapid increases in humidity, even if the normal trigger threshold is not reached. This unique feature ensures adequate ventilation, even for the smallest wet room. The night time relative humidity setback feature suppresses nuisance tripping as humidity gradually increases with falling temperature. Acoustically lined - low noise levels from only 20dB(A) @ 3m.

Models

Model	Stock Ref
Kinetic 200ZPH	407162
Kinetic 200ZH	449540
Kinetic 200ZMH	448778
Kinetic 300ZH	449536

Accessories

Model	Stock Ref
200ZPH 45% Coarse (G3) 2x Filter	407584
200ZH/ZMH 45% Coarse (G3) 2x Filter	449524

200ZH/ZMH ePM10 50% Pollen (M5) 1x Filter	404574
300ZH 45% Coarse (G3) 2x Filter	449575
300ZH ePM10 50% Pollen (M5) 1x Filter	404575
Acoustic Purge Fan	477988
Acoustic Purge Fan XL	479829

Multiple Control Options:

Five Volt-free pairs of switch terminals for sensor inputs allow boosting from a full range of Vent-Axia controllers - humidistats, PIR, timers.

Two terminals with 0-24V outputs allow 0V to 10V proportional control by sophisticated controllers such as CO₂ sensors and proportional humidistats.

Switch-live for boosting via light switches (220-240V AC) or manual Normal/Boost switches. This connection has the advantage of Delay-On and Delay-Off facility. Delay-On enables you to prevent the Boost airflow between 0 and 10 minutes after a light switch has been activated. Delay-Off allows the Boost airflow to continue after a light switch is turned off to ensure effective clearance of humidity. This timer is adjustable between 0 and 25 minutes.

Summer Bypass

An internal damper operates when the external temperature is below the internal temperature, and the internal temperature is too high.

The bypass opens and allows the cooler outside air to help cool the dwelling.

Normal mode: Fans run on Normal speed with bypass open until the internal dwelling temperature falls below the set 'Indoor' (maximum desired) temperature.

Evening Purge mode: The fans run on Boost speed until the internal temperature falls below the set 'Indoor' temperature. If, after five hours the internal temperature is still above the set 'Indoor' temperature, the unit will switch down to normal speed for the remainder of the 'bypass open' period.

Nighttime Purge mode: As Evening Purge, except that the unit will continue on Boost speed until the internal air temperature reaches the 'Outdoor' temperature set point (Default 14°C). This mode gives pre-cooling of the dwelling for the following day.

In Evening and Night Time Purge modes, the user can turn off the boost function by pressing the Boost button.

Frost Protection

In cold climates there is a possibility of frost building up on the intake side of the heat exchanger. In order to prevent damage, the Kinetic reduces supply flow while maintaining extract flow at temperatures down to -20°C.

SEC Class

Model	SEC Class
Kinetic 200ZH/ZPH/ZMH	A
Kinetic 300ZH	A

SAP PCDB Test Results

200ZPH	SAP 2009		SAP 2012	
	Thermal Efficiency %	SFP (W/l/s)	Thermal Efficiency %	SFP (W/l/s)
K+1	86	0.62	84	0.67
K+2	84	0.65	82	0.82
K+3	83	0.76	80	1.07

200ZH/ZMH	SAP 2009		SAP 2012	
	Thermal Efficiency %	SFP (W/l/s)	Thermal Efficiency %	SFP (W/l/s)
K+1	80	0.69	81	0.73
K+2	81	0.70	81	0.89
K+3	80	0.80	79	1.12
K+4	80	0.97	78	1.39
K+5	79	1.14		

300ZH	SAP 2009		SAP 2012	
	Thermal Efficiency %	SFP (W/l/s)	Thermal Efficiency %	SFP (W/l/s)
K+1	77	0.59	78	0.54
K+2	78	0.51	78	0.61
K+3	78	0.57	78	0.75
K+4	78	0.66	78	0.93
K+5	78	0.76	77	1.13
K+6	78	0.88	76	1.35
K+7	77	1.05		

Dimensions (mm)

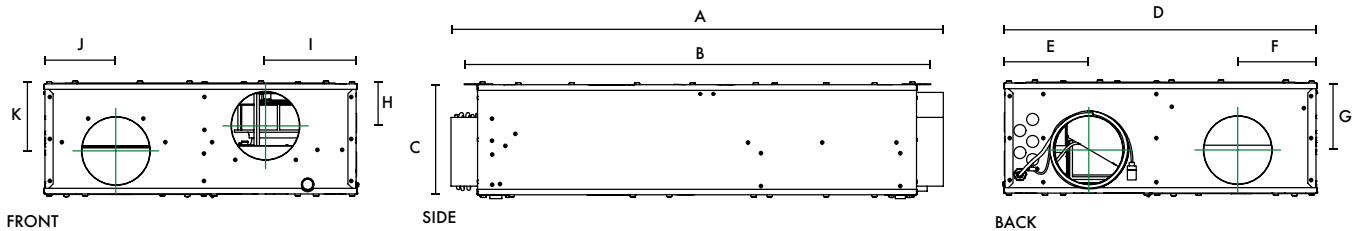

Model	A	B	C	D	E	F	G	H	I	J	K	Spigots Ø
200ZH	895	849	200	570	155	144	122	76	167	131	122	125
300ZH	985	940	301	720	184	179	187	102	279	174	187	150

Weight: 200ZH - 26kg, 300ZH - 38kg

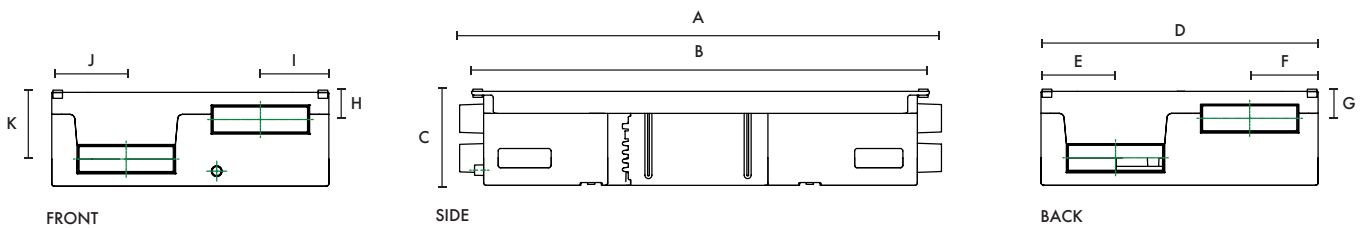

Model	A	B	C	D	E	F	G	H	I	J	K	Spigots
200ZPH	1000	950	200	575	155	142	60	61	142	154	143	204x60
200ZMH*	895	849	200	570	195	140	54	66	168	138	143	204x60

Weight: 200ZPH - 14kg, 200ZMH - 26kg

*Galvanized steel outer case construction

Performance - 200ZH/ZMH/ZPH Model

Fan speeds are fully adjustable within the performance range.

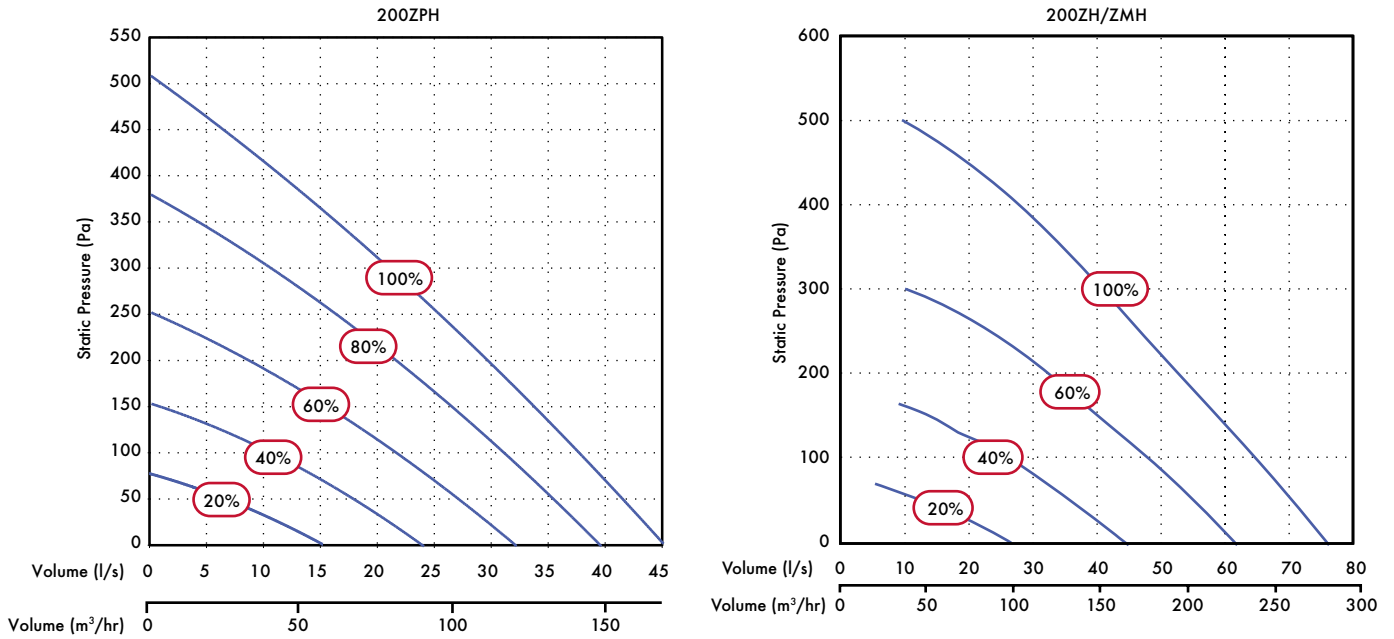

Sound Data - 200ZPH Model

Speed	Test mode	63	125	250	500	1k	2k	4k	8k	dB(A) at 3m
20%	Breakout	48.3	41.3	37.7	35.8	34.5	28.2	26	31.2	21.5
	Supply	39.6	37.1	36	32.9	30.6	22.9	24.9	29.4	23.1
	Extract	49.4	40.7	35	30.4	26.3	22.5	23.6	30.1	20.8
40%	Breakout	47.8	42.2	46.7	40.6	40.2	34.2	28.1	31.2	25.3
	Supply	45.7	38.3	40.7	39	38.1	28.7	24.9	28.5	28.1
	Extract	50	45.5	39.9	37	34.3	28.6	25.1	30.6	24.3
60%	Breakout	54.4	51.2	53.8	46.2	43	38.9	33.8	32	29.7
	Supply	46.1	49.2	45.3	44.4	42.4	35.2	27	29.3	32.7
	Extract	49.5	41.9	45.4	41.7	39.4	35.2	27.6	30.3	27.7
80%	Breakout	50.4	51.2	56.7	53.9	48.5	43.2	39.9	34.9	34.5
	Supply	52.9	48.9	47.5	51.3	47.2	40.8	31.2	30	36.8
	Extract	48.9	43.3	46.8	50	42.4	38.6	31.3	30.1	32.2
100%	Breakout	49.3	49.8	52.9	54	51	46.3	41.2	35.7	35.1
	Supply	43.8	45.8	50.7	56.3	50	44.3	35.7	29.7	38.2
	Extract	53.2	46.9	48	52.8	45.4	42.1	35.1	30.5	34.9

Sound Data - 200ZH/ZMH Model

Flow %	Test mode	63	125	250	500	1k	2k	4k	8k	dB(A) at 3m
20	Supply	50.3	54	50.1	45.5	37	36	27.5	31.1	30.0
	Extract	47.2	47.7	46.6	41.8	30.7	27.9	24.6	30.5	26.3
	Breakout	48.8	55.8	51.2	43.8	32.4	29.0	25.4	30.8	26.8
40	Supply	52.7	61.7	60.1	61.8	47.4	45.1	38.1	40.1	42.7
	Extract	50.7	55.4	55.0	51.5	37.5	34.6	25.9	30.7	33.9
	Breakout	53.7	60.1	61.1	50.7	40.2	35.8	27.1	30.3	34.0
60	Supply	52.8	64.5	66.7	59.4	51.1	51.1	42.9	39.3	44.0
	Extract	50.6	59.0	62.1	57.1	43.7	40.0	29.0	31.6	39.7
	Breakout	55.1	64.4	66.8	57.5	47.0	41.4	32.0	32.0	39.7
100	Supply	58.3	69.2	68.6	64.6	56.9	56.1	47.9	45.6	48.1
	Extract	51.8	63.1	64.9	63.9	52.4	45.9	34.8	34.8	45.2
	Breakout	59.4	68.1	69.7	68.3	53.1	47.1	36.5	34.3	46.5

Tested according to BS 848. Breakout quoted spherical. Supply and extract quoted hemispherical.

Performance - 300ZH Model

Fan speeds are fully adjustable within the performance range.

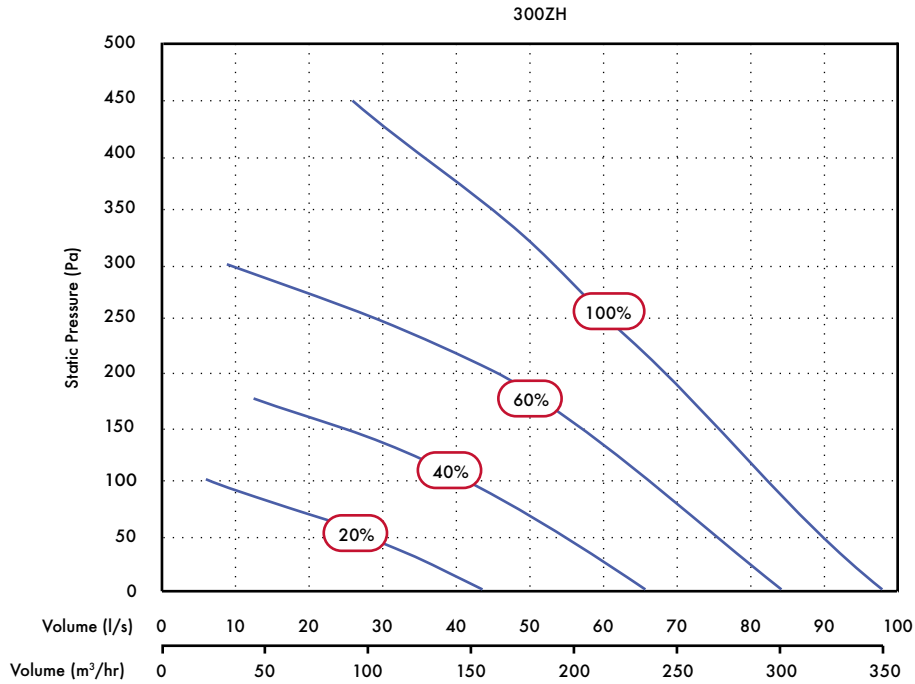

Sound Data - 300ZH Model

Flow l/s	Flow %	Test mode	63	125	250	500	1k	2k	4k	8k	dB(A) at 3m
26	10	Supply	42.5	42.8	38.3	32.9	28	24.6	25.5	30.3	26.3
		Extract	46.9	45	40.3	34.4	27.4	23	24.3	30.1	22.5
		Breakout	48.7	52.1	47.7	40.5	32.9	27.3	25.1	31.6	24.4
44	20	Supply	45.6	47	41.7	35.7	31.7	26.7	24.8	30	29.9
		Extract	46.9	48.6	47	38.2	29.5	25.3	23.8	29.9	25.3
		Breakout	50.2	56.4	53.9	46.3	37.5	32.5	25.2	31.4	28.8
55	30	Supply	44.4	46	52.9	39.4	35.1	31.9	25.5	30.5	33.9
		Extract	47	48	55.5	42.5	32.2	29.9	25.7	30.6	30.6
		Breakout	52.2	59.6	62	51.4	41.9	37.4	28.1	31.4	34.7
66	40	Supply	43.1	44.4	54.3	43.5	39.2	35.7	27.7	29.9	35.0
		Extract	48.9	49	58.4	45.9	35.7	33.4	25.3	29.9	33.4
		Breakout	54.6	58.3	66.1	52.6	39.3	36.5	31.1	35.3	37.7
85	60	Supply	44.7	49.8	58	50.4	45	41.9	30.6	30.3	39.1
		Extract	51	53.6	61.2	50.1	41.6	40.1	30.7	31.1	36.7
		Breakout	57.5	62.6	68.7	57.5	45.9	41	36.3	34	40.7
96	80	Supply	46	52.2	57.1	56.5	47.2	44.2	32.3	30.5	40.5
		Extract	55.5	55	63.1	53.4	44.3	41	33.5	31.4	38.8
		Breakout	62.2	65.7	68.8	63	50.8	43.8	38.8	35.4	42.9
98	100	Supply	46.6	52.3	57	55.4	47.1	43.7	32.1	30.3	40.1
		Extract	53.7	55.2	63.3	53.3	44.1	41.2	33.2	31.5	38.9
		Breakout	62.2	73.8	77.4	74.1	67.4	61	53.6	45.4	53.9

Tested according to BS848. Breakout quoted spherical. Supply and Extract quoted hemispherical.

Consultant's Specification

Operation

The supply and extract ventilation unit shall be as Sentinel Kinetic Z as manufactured by Vent-Axia and shall be sized as indicated on the drawings and shall be in accordance with the particular specification; 200Z - 200mm deep, 300Z - 300mm deep.

The Sentinel Kinetic Z shall automatically vary the ventilation rate via EC/DC motors, as it receives signals from one of the optional interconnected sensors. When a signal is received, the fans shall either vary their speed proportionally or on a trickle and boost principle.

The unit shall have the facility to commission the supply and extract fans individually via the wired remote control unit. The fans themselves shall have independent, infinitely variable speed control.

Unit Specification (200Z/ZM, 300ZH)

The unit shall be manufactured with a galvanized steel outer case construction and shall have a high efficiency aluminium heat exchanger.

Unit Specification (200ZP)

The unit shall be manufactured with high density EPP case and shall have a high efficiency polymer heat exchanger.

The unit shall have supply and extract filters, automatic summer bypass, integral minimum and maximum infinitely variable speed controls with failure indication via the wired remote controller.

The unit shall have low energy, high efficiency EC/DC fan/motor assemblies with sealed for life bearings. The impellers shall be high efficiency backward curved centrifugal type.

The unit shall have a heat exchanger cell with a thermal efficiency of up to 81% when tested to EN 308. This shall be protected by ISO 45% Coarse (G3) Filter 2pk grade synthetic filters on supply and extract. Complete with a condensate drip tray and drain connection.

The unit shall be constructed with a removable access panel allowing full maintenance access from below. The removable panel shall provide access to the following:

- ✓ Supply or extract fan
- ✓ Supply and extract filter
- ✓ Heat exchanger
- ✓ Access to the electrical connections

Access shall be provided for wiring termination and setup/commissioning.

Sound tested to BS EN 13141-7:2010

Standard Controls

All Sentinel Kinetic Z units shall incorporate the following functions integrally mounted, pre-wired and factory fitted by the manufacturer:

- ✓ Infinitely variable fan speed control on supply and extract
- ✓ Min/max ventilation control/set point
- ✓ Heating interlocks
- ✓ 0-10V proportional speed adjustment
- ✓ Volt free contacts
- ✓ 24V sensor supply
- ✓ On/off or trickle boost function from remote switch, e.g. PIR occupancy detector
- ✓ The unit shall be controlled by the 'Sentinel' control devices (enablers and sensors) as detailed in the schedule or on the drawings

- ✓ Fully automatic summer bypass
- ✓ Switched Live input with adjustable 'delay-on' feature
- ✓ Fan failure or component failure indicated via individual fault code display
- ✓ Running time counter
- ✓ Control panel PIN number lock
- ✓ Automatic frost protection effective to -20°C
- ✓ The unit shall incorporate ('H' models) an integral humidity sensor with the following features:
 - Ambient Response: Raises the humidity trigger point as dwelling temperature reduces
 - Rapid Response: Monitors the rate of change in humidity and triggers increased airflow even if the humidity trigger threshold is not reached
 - Proportional Response: Incrementally increases the fan speed to reduce noise and reduce energy consumption

The unit shall be controlled by the 'Sentinel' control devices (enablers and sensors) as detailed in the schedule or on the drawings.

Mounting Option



Slab

Airflow Direction

View from beneath (drawing for airflow demonstration only - not intended to be an accurate representation of the product)

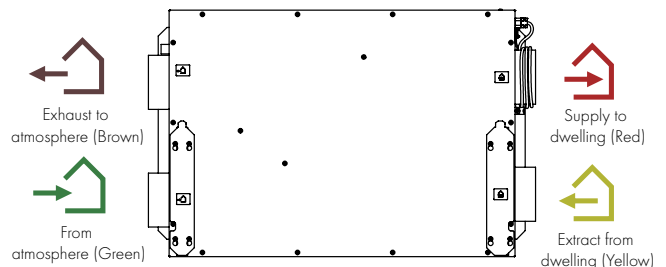

Electrical Connection

Please note: Electrical connection should be carried out by an appropriately qualified person and in accordance with current wiring regulations.

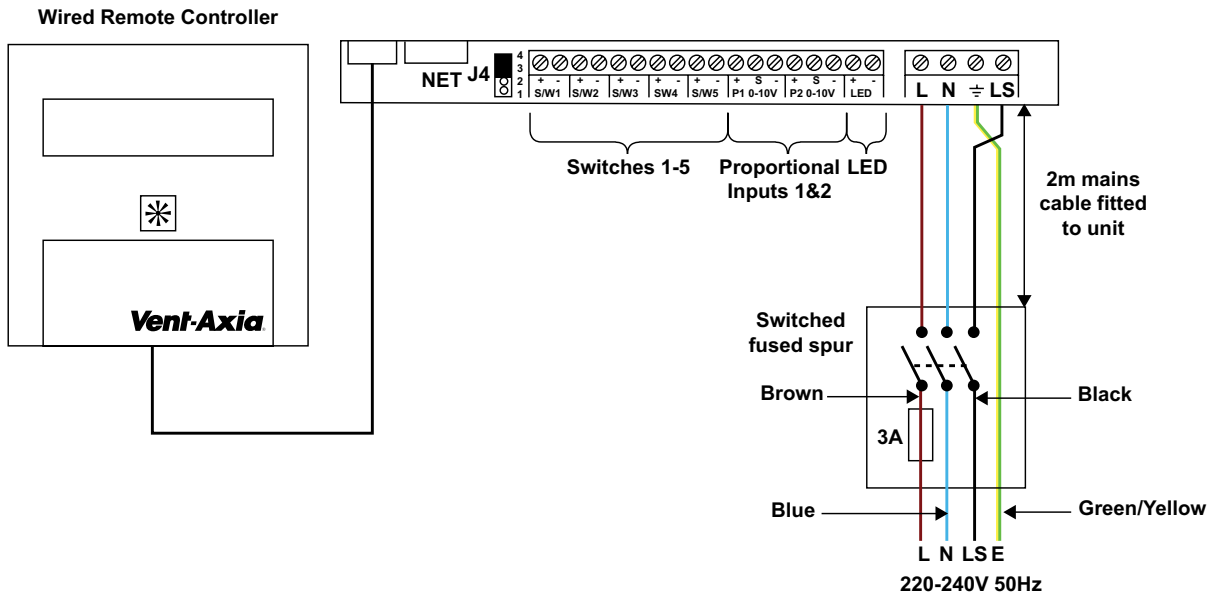

Trickle to Boost by two lighting circuits or Trickle/Boost Switch

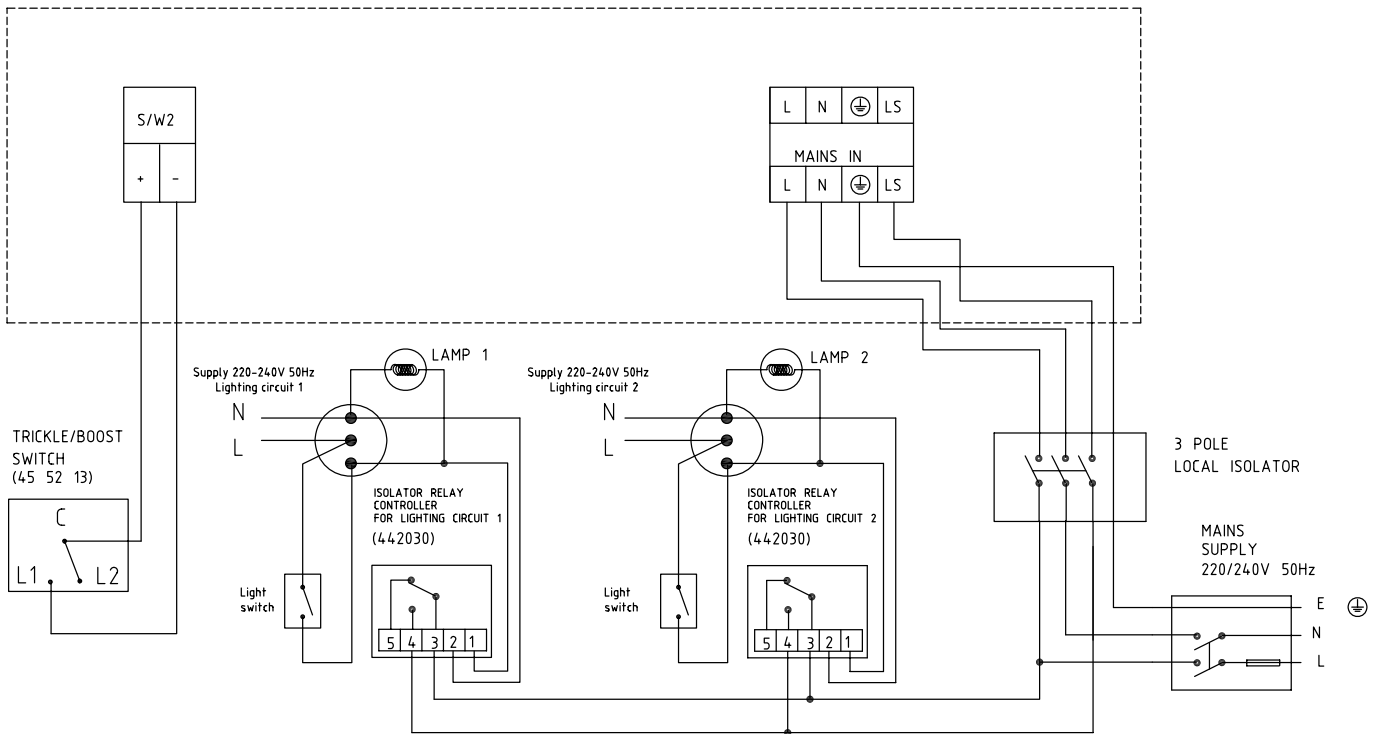

Lo-Carbon Kinetic Plus E

- Acoustic Enclosure option for reduced breakout noise
- Acoustic Top Box option for reduced in-duct noise
- Lightweight for easy installation
- Easy access filters
- External condensate connection
- Compatible with a range of controls: PIR, Humidistat
- Horizontal duct option for space-saving installations
- Up to 94% heat recovery
- Summer mode
- Manufactured in the UK
- Switched live inputs (Light switch control)



A wholehouse heat recovery system with up to 94% energy efficiency. An easily accessible heat recovery cube protected by two removable ISO 45% Coarse (G3) Filters. Two Lo-Carbon Energy Saving EC/DC fans ensure long life (typically over double the life of AC motors) and lowest possible energy use. Fully insulated construction with built-in condensation drain.

Lo-Carbon Kinetic Plus E meets the latest requirements of the Building Regulations Approved Document F for wholehouse system ventilation.

The Lo-Carbon Kinetic Plus E model has two adjustable speeds, normal and boost. On the front of the unit is the controller that can be used to preset the speeds to any required performance, up to 111l/s (400m³/hr) 150Pa. Offering 'Close Control' to prevent over ventilating. Acoustically lined - low noise levels from only 20dB(A) @ 3m.

For scenarios where noise is a critical issue, an Acoustic Enclosure is available to reduce breakout noise and the Acoustic Top Box will reduce in-duct noise at key frequencies.

Left or Right Hand Installation

Units are supplied right handed with duct spigots to outside on the right hand side. These can be reversed onsite by simply removing the control panel, rotating the unit 180 degrees and reattaching the control panel.

Spigot Options

The combination of spigot options allows installation in confined locations. If vertical and horizontal connections are required on the same outlet/inlet, additional spigots can be supplied.

Filter Check

An LED on the control panel illuminates at 6 month intervals to remind users to check and clean the filters.

Frost Protection

The Kinetic E range benefits from an automatic frost protection system to prevent the heat recovery cell freezing in very cold weather, while at the same time maintaining ventilation.

Control Options

There are two LS (Switched Live) inputs allowing the unit to be connected to a number of sensors and controllers such as Timespan, Ambient Response Humidistat. One of the LS connections also benefits from a 'Delay-On' feature which prevents the unit boosting unnecessarily. Switching on the control panel allows activation of the Summer Mode.

Model

Model	Stock Ref
Kinetic Plus E	449059
Kinetic Plus E with Acoustic Top Box & Enclosure	479562
Kinetic Plus E with Acoustic Top Box	479561
Kinetic Plus E with Acoustic Enclosure	479560

Accessories

Model	Stock Ref
ISO 45% Coarse (G3) Filter 2pk	403702
ISO ePM10 50% (M5) Filter	444201
Isolator Relay Controller	442030
180mm/200mm Spigot Kit (One per pack)	446523

SEC Class

Model	SEC Class
Kinetic Plus E	A+

SAP PCDB Test Results

	SAP 2009		SAP 2012	
	Thermal Efficiency %	SFP (W/l/s)	Thermal Efficiency %	SFP (W/l/s)
K + 1	94	0.41	94	0.40
K + 2	94	0.40	94	0.43
K + 3	94	0.43	94	0.53
K + 4	94	0.45	93	0.65
K + 5	93	0.52	93	0.78
K + 6	93	0.61	92	0.93
K + 7	93	0.73		

Dimensions (mm) Unit

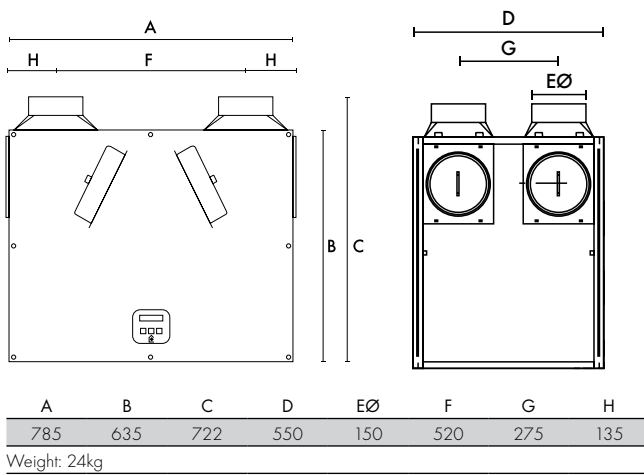

Performance

Fan speeds are fully adjustable within the performance range.

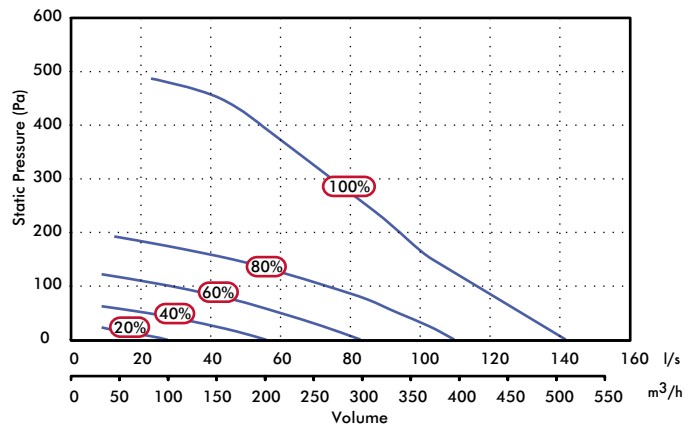

Acoustic Solution

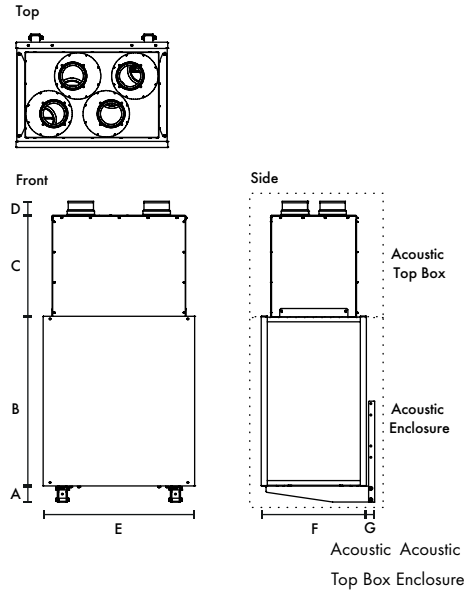

A	B	C	D	E	F	G	kg	kg	Spigot
80	733	501	71	855	583	40	17	33	150

Sound Data (Unit only)

Unit setting	Test mode	Octave band, Hz, dB SWL									SPL dB(A)	
		63	125	250	500	1k	2k	4k	8k	LwA	at 3m	
20%	Supply	46.5	54.3	46.4	44.8	36.2	28.5	24.5	31.2	11.0	28.5	
	Extract	46.0	52.2	42.3	38.7	27.6	24.2	24.0	31.7	7.5	25.0	
	Breakout	48.5	42.6	43.3	38.9	35.8	29.3	23.8	30.7	2.3	22.8	
40%	Supply	50.3	59.1	54.5	56.5	47.0	39.9	26.3	31.7	20.5	38.0	
	Extract	46.8	51.6	47.8	44.4	32.7	27.4	24.4	31.7	10.5	28.0	
	Breakout	48.4	51.2	53.4	46.0	41.0	34.6	25.0	30.3	8.0	28.5	
60%	Supply	52.4	57.2	60.4	60.9	55.8	50.3	33.1	33.9	26.1	43.6	
	Extract	50.0	49.8	56.8	52.4	40.2	35.9	33.4	39.8	17.7	35.2	
	Breakout	55.0	49.6	59.7	54.5	46.9	39.9	33.6	39.2	14.4	34.9	
80%	Supply	54.9	60.7	67.4	66.6	61.8	56.0	39.6	37.7	32.0	49.5	
	Extract	50.4	52.0	61.2	56.6	45.1	39.6	34.2	40.2	21.6	39.1	
	Breakout	53.5	53.4	60.8	59.1	53.0	45.3	36.0	40.1	18.2	38.7	
100%	Supply	54.7	61.7	70.5	69.9	62.7	57.5	42.1	38.3	34.5	52.0	
	Extract	54.4	55.1	65.8	57.5	46.9	40.6	33.7	40.0	24.3	41.8	
	Breakout	56.6	54.6	60.5	60.7	54.7	45.9	36.5	39.6	19.5	40.0	

Sound Data (Unit with Acoustic Solution)

Unit setting	Test mode	Octave band, Hz, dB SWL									SPL dB(A)	
		63	125	250	500	1k	2k	4k	8k	LwA	at 3m	
20%	Supply	55.7	49.2	36.6	23.6	17.4	14.9	17.8	23.3	36.1	18.6	
	Extract	51.4	42.4	30.3	20.9	16.8	14.9	17.8	23.3	30.8	13.3	
	Breakout	37.4	39.7	30.0	22.7	15.6	14.0	17.9	23.3	28.4	7.9	
40%	Supply	59.7	59.7	45.5	32.2	22.2	15.2	17.9	23.3	45.1	27.6	
	Extract	54.8	55.0	38.0	26.8	18.1	14.9	17.8	23.3	40.2	22.7	
	Breakout	45.7	48.5	39.9	32.8	24.2	17.5	18.0	23.4	36.8	16.3	
60%	Supply	66.1	61.9	53.6	41.0	29.8	18.3	18.0	23.3	49.5	32.0	
	Extract	60.6	55.9	48.4	34.9	23.8	16.3	17.9	23.3	43.8	26.3	
	Breakout	51.1	51.0	52.4	40.9	33.2	26.1	19.7	23.4	44.5	24.0	
80%	Supply	70.0	67.6	68.5	48.1	37.9	25.3	19.4	23.6	60.7	43.2	
	Extract	65.4	59.7	57.2	41.6	31.3	21.8	19.2	23.4	50.4	32.9	
	Breakout	55.6	55.6	57.9	47.9	40.4	34.3	26.1	23.7	51.3	30.8	
100%	Supply	72.1	70.1	66.4	51.6	41.9	29.7	21.7	24.0	60.0	42.5	
	Extract	68.2	62.4	60.6	45.5	36.0	26.6	21.7	23.6	53.8	36.3	
	Breakout	57.6	58.8	63.3	51.0	44.2	38.5	31.0	24.9	56.3	35.8	

Tested according to BS848. Breakout quoted spherical. Supply and Extract quoted hemispherical. For in-duct data, end reflections are added.

Consultant's Specification

Operation

The supply and extract ventilation unit shall be as Kinetic Plus E as manufactured by Vent-Axia and shall be sized as indicated on the drawings and shall be in accordance with the particular specification.

Supply air to the room shall be pre-heated by the extract air via the integrated composite plastic counterflow heat recovery cell. The Kinetic Plus E shall automatically vary the ventilation rate via EC/DC motors, as it receives signals from one of the optional interconnected sensors. When a signal is received, the fans shall vary their speed on a trickle and boost principle. The unit shall have the facility to commission the supply and extract fans individually via in-built minimum and maximum speed adjustment. The fans themselves shall have independent, infinitely variable speed control.

Unit Specification

The unit shall be manufactured with an ABS outer case construction, and incorporate a reversible core to allow for left or right hand mounting. The unit shall have a high efficiency composite plastic counterflow heat exchanger, supply and extract filters, integral minimum and maximum infinitely variable speed controls with fascia mounted failure indication.

The unit shall have low energy, high efficiency EC/DC fan/motor assemblies with sealed for life bearings. The impellers shall be high efficiency backward curved centrifugal type. The unit shall have a heat exchanger cell with a thermal efficiency of up to 94% when tested to EN 308. This shall be protected by ISO 45% Coarse (G3) Filter 2pk grade synthetic filters on supply and extract. Complete with a condensate drip tray and drain connection.

To reduce breakout noise, the MVHR unit shall be provided with an Acoustic Enclosure of steel construction lined with class 'O' acoustic foam. To reduce in-duct noise, the top of the MVHR shall be fitted with an Acoustic Top Box to provide attenuation to the 4 ducts of the unit. This Acoustic Top Box shall be of steel construction lined with acoustic class 'O' foam with the MVHR spigots linked to the Top Box via 4 separate attenuated ducts. The acoustic enclosure and top box shall each be independently tested for noise to BS EN 13141-7.

The unit shall be constructed with a removable Core allowing full maintenance access. The removable Core shall provide access to the following:

- ✓ Supply and extract filter
- ✓ Heat exchanger
- ✓ Access to the electrical connections

Access shall be provided for wiring termination and setup/commissioning.

Sound tested to BS EN 13141-7:2010

Standard Controls

All Kinetic Plus E units shall incorporate the following functions integrally mounted, pre-wired and factory fitted by the manufacturer:

- ✓ Integral infinitely variable fan speed control on supply and extract
- ✓ Integral min/max ventilation control/set point
- ✓ Integral on/off or trickle boost function from remote switch, e.g. PIR occupancy detector
- ✓ Switched Live input with adjustable 'delay-on' feature
- ✓ Tool free filter access
- ✓ Frost protection
- ✓ LED 'filter check' indicator

Mounting Option

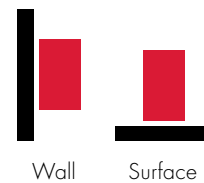

Airflow Direction

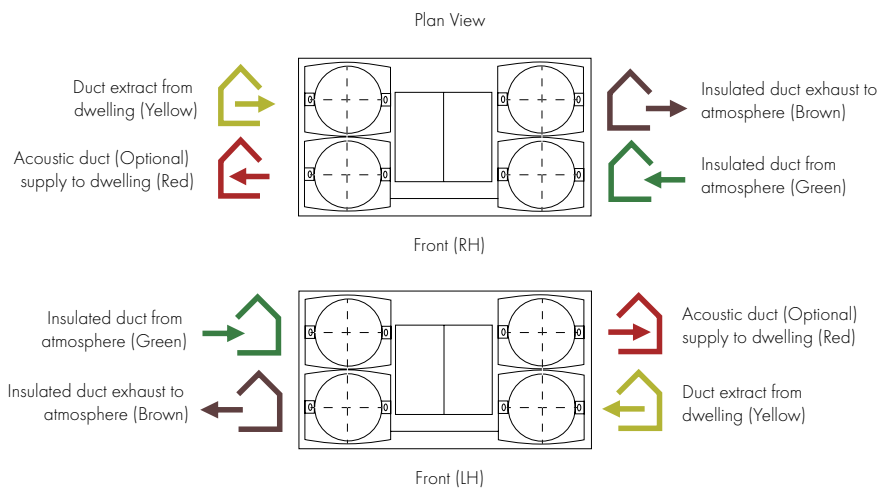

Electrical Connection

The unit can be switched to boost by applying 230 V to the LS1 or LS2 inputs. Alternatively, the boost button on the control unit may be used.

Mains Cable Connections

Terminal No.	Name	Description
L	Mains Live	220-240 V AC, 50 Hz input
N	Mains Neutral	220-240 V AC, 50 Hz input
EARTH	Mains Earth	Earthing connector
LS1	Switched Live 1	220-240 V AC, 50 Hz input
LS2	Switched Live 2	220-240 V AC, 50 Hz input

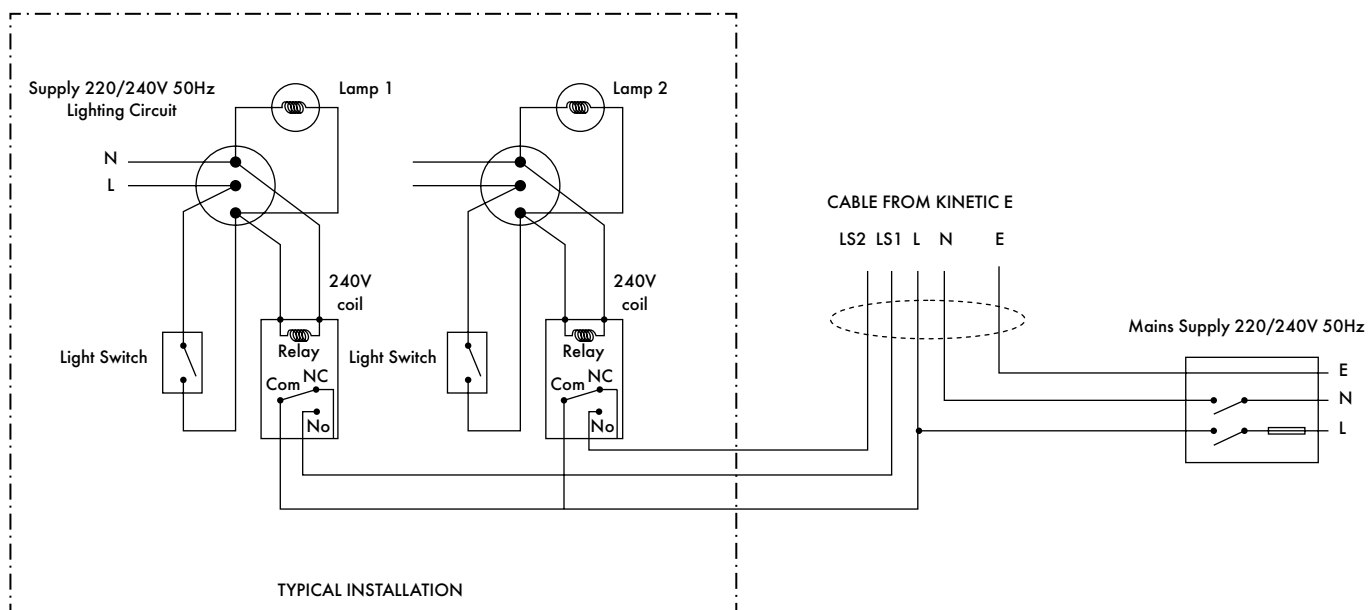

Integra

- Heat recovery unit for smaller residential or commercial applications up to 180m²
- Up to 70% heat recovery
- Low power consumption
- Effective condensation control
- Summer mode



The Integra heat recovery unit has been specially designed to provide ventilation for flats or rooms in residential, commercial, educational or leisure applications. Balanced ventilation is achieved by using nominal 100mm diameter rigid ducting.

Using a high performance, polymeric heat exchange cube, together with two powerful fans, the Vent-Axia Integra achieves efficiencies of up to 70%.

The compact cube interleaves outgoing moist air with incoming fresh air, allowing the heat from one to warm the other without the two air streams mixing. Energy is saved on room heating, with no power being used by the cube itself.

Performance of Integra: Up to 49l/s FID. Ideal for installation in ceilings voids or cupboards.

The 150VA Transformer enables the selection of trickle settings to match dwelling volume.

Models

Model	Stock Ref
Integra	456864

Controller

Model	Stock Ref
Controller 150VA	563538

Airflow Direction

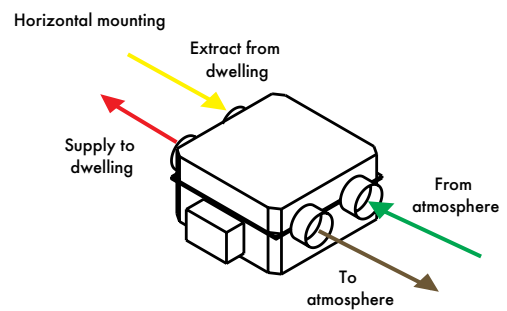

SEC Class

Model	SEC Class	SEC Class (inc. LDC)
Integra	F	C

Dimensions (mm)

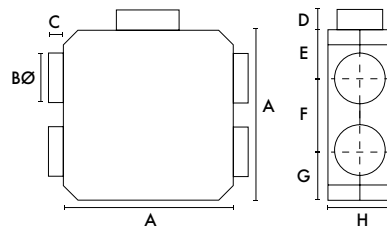

A	BØ	C	D	E	F	G	H
400	98	50	65	85	230	85	210

Weight: 6.5kg

Performance

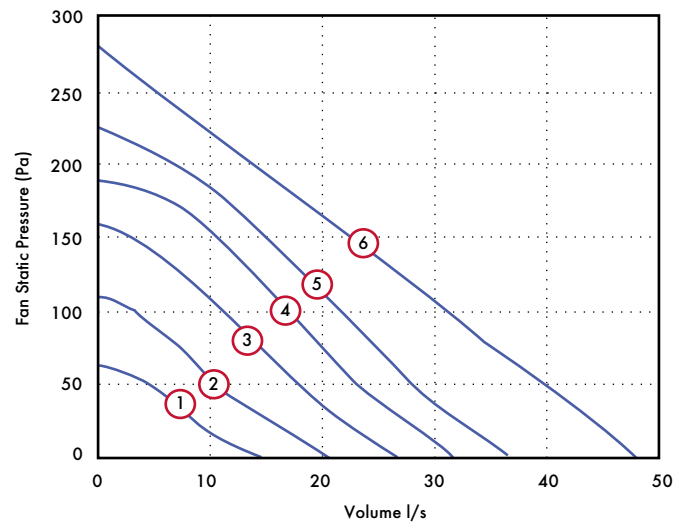

Motor Speed/Curve	Volume (l/s) (FID)	Voltage (V)	Wattage (W)
1	15	80	32
2	21	100	47
3	27	120	64
4	32	140	81
5	37	160	99
6	49	240	182

Integra to be used with a 150VA Transformer for maximum controllability.

Integra Plus EC

- Heat recovery unit for larger residential or commercial applications
- Up to 70% heat recovery
- Low power consumption
- Effective condensation control
- 3 speed control
- Summer mode
- EC motors



Easy Installation

The Vent-Axia Integra Plus EC is designed for mounting in ceiling voids, lofts and above a suspended ceiling. Four 150mm spigots are provided for simple connection to insulated flexible or rigid ventilation ducting. The unit comes complete with a 22mm condensate outlet.

The Integra Plus EC incorporates two adjustable speeds and a Purge setting (full Speed).

Switching on the controller allows activation of the Summer Mode.

Model

Model	Stock Ref
Integra Plus EC	437666EC

SEC Class

Model	SEC Class	SEC Class (inc. LDC)
Integra Plus EC	B	A

Controllers & Sensors

Model	Stock Ref
Ambient Response Humidistat	563550
Visionex PIR	459623
TIM2	370346

Airflow Direction

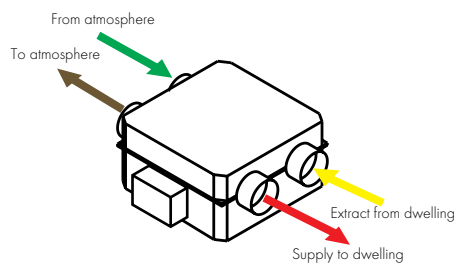

Dimensions (mm)

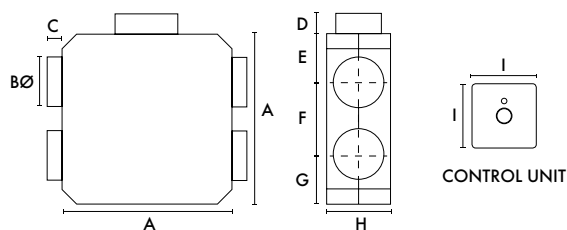

A	ØB	C	D	E	F	G	H	I
580	150	100	64	125	350	125	305	85

Weight: 17kg fan box

Performance

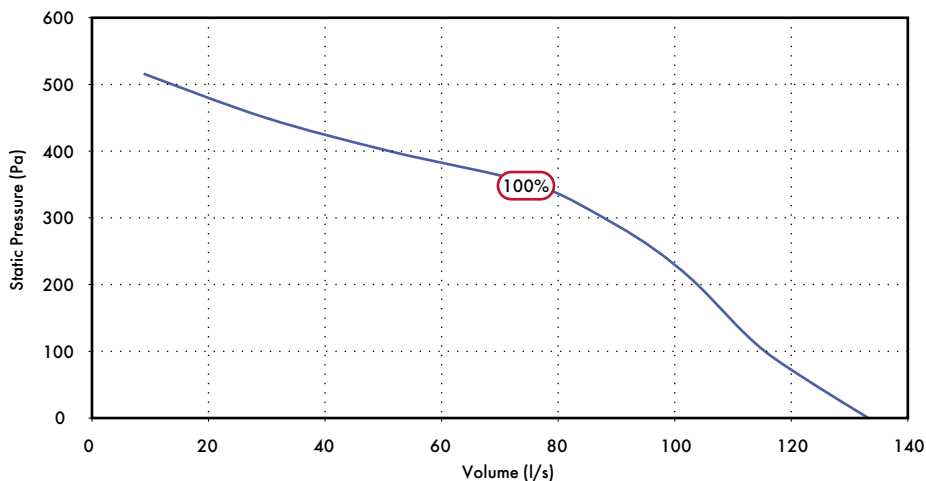

Sound Data

Flow, l/s	Unit setting V	Test mode	Octave band, Hz, dB SWL								SPL dB(A) at 3m
			63	125	250	500	1k	2k	4k	8k	
55	4	Supply	39.2	43.1	44.5	47.1	42.6	36.0	29.3	30.7	30.7
		Extract	47.0	42.4	38.6	40.4	35.5	28.0	27.9	32.6	25.3
		Breakout	43.2	42.7	38.2	37.6	33.4	28.4	27.6	31.5	21.7
69	5	Supply	42.0	47.6	46.1	49.9	48.8	41.2	33.7	32.5	34.4
		Extract	47.8	42.2	41.4	43.2	40.4	29.6	27.7	32.5	27.7
		Breakout	45.2	45.7	41.9	40.7	37.3	30.5	27.5	32.4	23.8
79	6	Supply	46.0	49.7	50.6	54.0	54.4	45.9	39.6	36.9	38.7
		Extract	44.5	43.2	44.8	46.4	46.2	32.2	28.4	32.3	31.4
		Breakout	46.2	47.2	44.3	43.4	43.1	32.8	28.5	32.2	26.6
81	6.6	Supply	47.0	52.5	53.8	56.4	58.3	48.8	42.8	40.8	41.8
		Extract	50.3	45.3	47.7	48.5	47.4	35.0	30.7	32.9	33.0
		Breakout	45.5	47.9	45.5	45.5	45.5	34.0	29.2	31.5	28.3
95	7	Supply	48.9	54.1	56.3	58.0	59.2	51.0	45.9	43.8	43.3
		Extract	47.6	46.5	49.4	49.7	48.3	37.0	31.1	32.3	34.0
		Breakout	49.0	49.5	48.2	47.5	47.3	36.7	31.1	32.3	30.1
109	8	Supply	51.0	58.2	57.4	60.1	61.2	54.4	48.9	48.0	45.6
		Extract	56.2	52.4	51.7	53.1	49.6	39.5	33.8	33.2	36.3
		Breakout	51.8	53.9	51.3	50.7	48.7	40.3	34.0	32.5	32.2
113	9	Supply	49.1	56.1	59.4	62.8	63.3	57.2	52.1	50.8	47.4
		Extract	54.5	50.9	52.4	54.5	51.4	42.3	35.3	33.8	37.8
		Breakout	53.6	54.3	52.8	52.3	50.8	43.4	36.2	33.5	34.1

Tested according to BS848. Breakout quoted spherical. Supply and Extract quoted hemispherical.

HR100R/RS

- Controls condensation and odours
- Eliminates mould growth
- Up to 70% heat recovery - saves energy
- Extremely quiet operation
- Two speed settings
- ERP exempt (<30W)



The HR100R and HR100RS are ideal for single bedrooms/bathroom applications situated in hotel rooms, nursing homes and residential care homes.

The HR100R features top access making it ideal for loft installations.

The HR100RS features bottom access for installation on the slab above a suspended ceiling.

The HR100R/RS is a self-contained heat recovery unit for mounting in lofts and suspended ceilings. The unit is supplied without controls to allow for the unit to be tailored to suit the individual requirements.

Compatible with standard 100mm ducting for connection to internal grilles and external cowl.

The unit comes fitted with a single 2-speed motor, and provides continuous low volume ventilation with a boost option. A variety of control devices are available for manual or automatic speed control.

An integral heat exchanger transfers heat from the outgoing stale air to the fresh air supply, raising the supply air temperature whilst at the same time reducing its relative humidity.

Up to 18l/s FID capacity. The unit provides superior control of condensation and odours, ideal for bathrooms or small internal rooms.

Models

HR100R

Top access - ideal in loft installations.

Model	Stock Ref
HR100R	370377

HR100RS

Bottom access - ideal for suspended ceilings.

Model	Stock Ref
HR100RS	435004

Controllers

Normal Boost Switch

A single gang switch to boost from high to low speeds on all heat recovery systems.

85 x 85 x 10mm (H x W x D)

Model	Stock Ref
Normal Boost Switch	455213

HR100RS Version

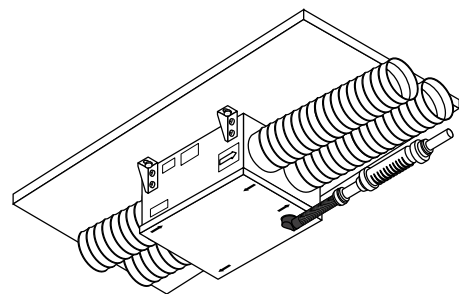

Dimensions (mm)

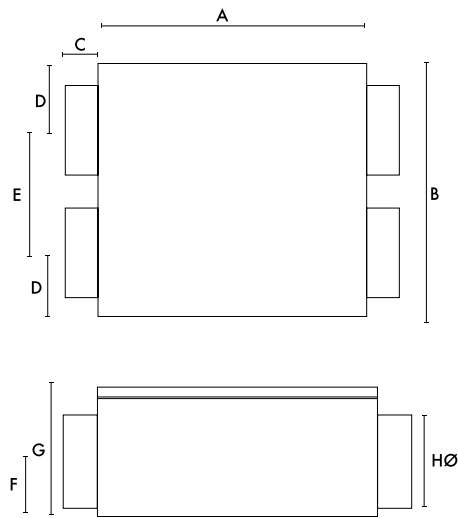

A	B	C	D	E	F	G	HØ
305	240	50	60	120	70	160	98

Performance

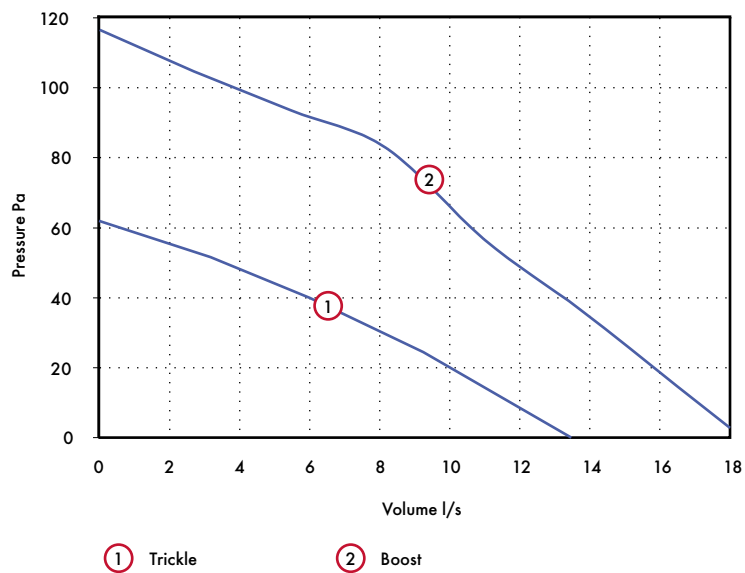

Model	Weight kg	Extract Perf. l/s		Watts		dB(A) @ 3m*	
		Boost	Trickle	Boost	Trickle	Boost	Trickle
HR100R	5.6	18.3	13.6	29	19	30	20
HR100RS	5.6	18.3	13.6	29	19	30	20

Mains electrical supply: 230V/50Hz

HR200V

- Powered heat recovery module for smaller commercial applications
- Up to 70% heat recovery
- 150mm duct connection
- Extremely quiet on low speeds
- Low power consumption
- Washable heat exchanger
- Pre-wired to a flexible cable



A ducted heat recovery unit for residential or commercial applications. The HR200V is self-contained and includes two mixed flow speed controllable fans. Using a high performance, polymeric heat exchange cube together with two power fans, the HR200V can boast a temperature efficiency of up to 70%. Low speed for trickle ventilation mode.

Specially designed to provide ventilation for small internal rooms in commercial, educational and leisure applications. Ventilation is achieved by using nominal 150mm diameter ducting.

Models

Model	Stock Ref
HR200V	14120010

Accessory

Model	Stock Ref
Transformer 150VA	563538

SEC Class

Model	SEC Class	SEC Class (inc. LDC)
HR200V	C	B

Dimensions (mm)

Weight: 15.5kg fan box, 5kg controller

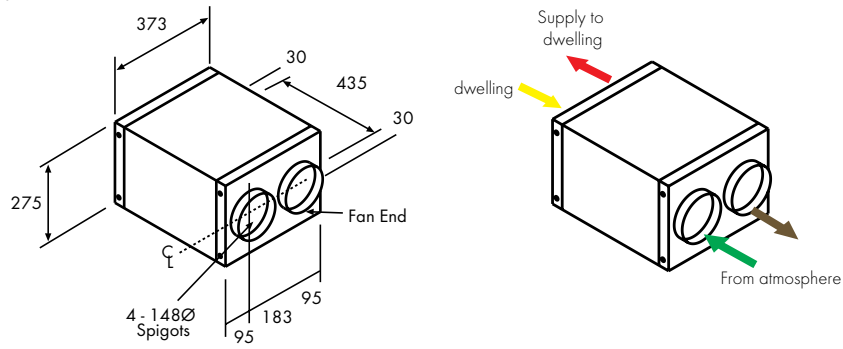

Performance

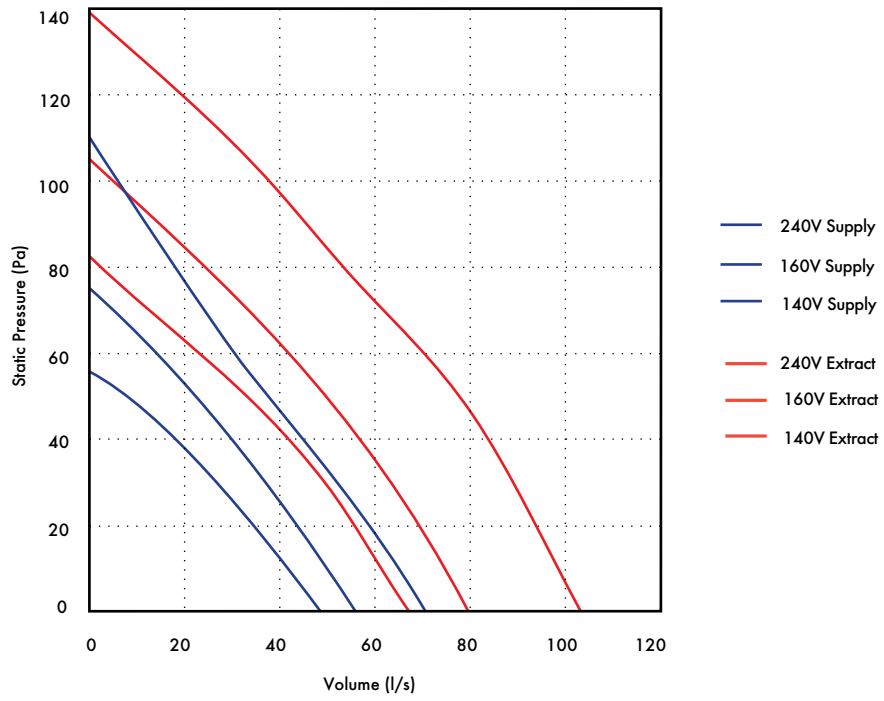

Motor Speed	1	2	3
Voltage	140	160	240
Watts	51.5	60	110
Volume l/s (FID) Supply	48.3	55.8	70.3
Extract	241	286	371

HR200V to be used with a 150VA Transformer for maximum controllability.

HR500

- Efficient 550m³/h heat recovery ventilation unit or high performance 900m³/h extract fan
- Lightweight, compact and easy to install
- Integral shutters on X type model
- Easy to clean
- Up to 70% heat recovery
- Controller with sensor mode, allows a range of sensors to be used in conjunction with the HR500 and HR500X units
- IPX5 rated



Heat Recovery Ventilation

HR500 heat recovery ventilation units for through the wall installation, which exhaust stale air whilst introducing warmed fresh air from the outside.

Ideal for computer rooms, classrooms, offices and the health and leisure industries. The Vent-Axia HR500 unit is the perfect solution for commercial areas that require a high performance balanced intake/extract ventilation scheme. As a heat recovery ventilation unit it moves a useful 153l/s of air.

The compact heat recovery cube interleaves outgoing warm air with incoming fresh air and allows the heat from one to warm the other without the two air streams mixing. Energy is saved on room heating with no power being used by the cube itself.

The HR500 and HR500X consist of a tough telescopic wall sleeve into which the main body of the unit is housed. Walls of up to 670mm thick can be easily accommodated. Behind the neat deflecting fascia grilles are the filters, the heat exchange cube and fan units. All wall sleeve components, the heat exchange cube and the fascia grilles are made of tough polymeric materials.

Electrical

Maximum ambient temperature +40°C.
Supply Voltage 220-240V/1/50Hz.

Models

HR500 Commercial

Wall-mounted intake/extract ventilation unit with built-in heat recovery facility. For commercial and leisure areas. Lightweight, compact and easy to install.

Model	Stock Ref
HR500	14101010

HR500X

As HR500 with shutters.

Model	Stock Ref
HR500X	14101070

Controller

HR500 Controller

Surface mounting. On/Off remote sensor mode. Heat exchange, single fan extract or twin fan extract modes. Infinitely variable speed. Minimum speed setting. Suitable for controlling up to 2x HR500. 86 x 156 x 53 (W x H x D).

Model	Stock Ref
HR500 Controller	W14301010

Dimensions (mm)

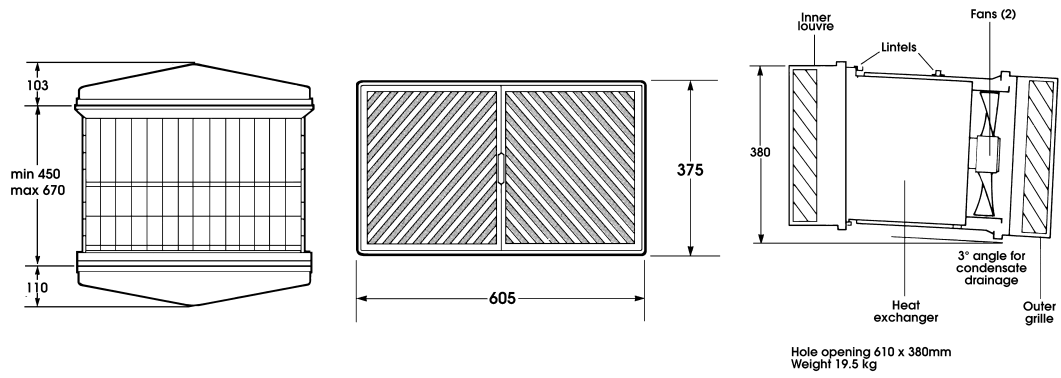

Performance

Model	Airflow performance (l/s)		Watts (max)	Sound dB(A) @ 3m (max)
	Heat recovery mode	Extract mode (max)		
HR500	153l/s	250l/s	200	53
HR500X	153l/s	250l/s	220	53

HR500D

- Self-contained unit with integral fans
- Up to 70% heat recovery
- External wall mounting



The HR500D is a self-contained unit with integral extract and supply fans to provide balanced ventilation and heat recovery via supply diffusers and extraction grilles. The unit is fully speed controllable.

The compact heat recovery cube interleaves outgoing warm air with incoming fresh air and allows the heat from one to warm the other without the two air streams mixing.

Energy is saved on room heating with no power being used by the cube itself.

Performance of HR500D: Supply and extract up to 174l/s FID capacity on heat recovery mode. Ideal for offices, computer rooms, pubs and clubs, etc.

Model

Surface mounting. On/Off remote sensor mode. Heat exchange, single fan extract or twin fan extract modes. Infinitely variable speed. Minimum speed setting. Suitable for controlling up to 2x HR500.

Model	Stock Ref
HR500D	370450

Controller

Model	Stock Ref
Speed Controller	W14301010

Dimensions (mm)

Hole opening: 610 x 381mm

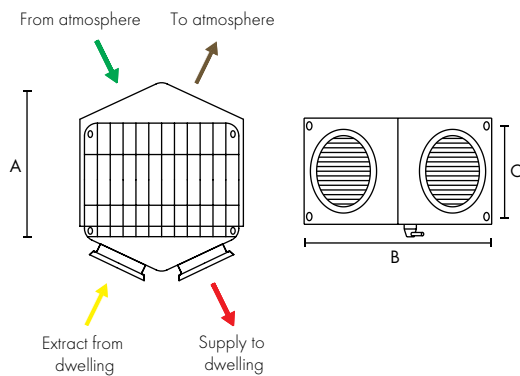

A	B	C
480-750	600	340

Performance Guide

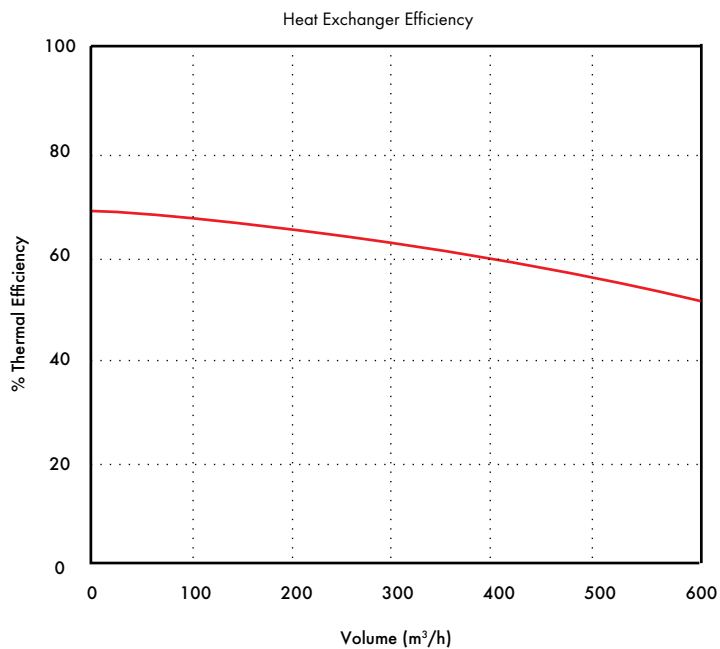

Airflow performance l/s (max)	Watts (max)	dB(A) @ 3m (max)	Weight kg
174 l/s	210	53	19

HR500EP/IP

- Passive - no fans
- Lightweight - easy installation
- Up to 70% heat recovery
- Internal wall mounting HR500IP
- External wall mounting HR500EP

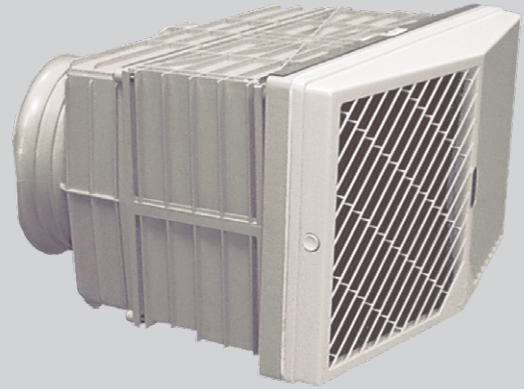

The unit is a semi-remote heat exchange unit with 70% heat recovery, designed for mounting in internal walls (HR500IP) and external walls (HR500EP) for installations using ducted extraction and fresh air supply. The HR500 units provides air movement via two independent in-line duct fans to suit length and configuration of ducting systems. The unit is ideal for use with in-line centrifugal type fans and compatible accessories. Performance of HR500EP and HR500IP: Up to 244 l/s FID capacity (balanced airflow). Ideal for computer rooms, classrooms, offices and the health & leisure industries.

Model

Model	Stock Ref
HR500IP	370447
HR500EP	370451

EP Unit

Hole opening: 610 x 381 mm

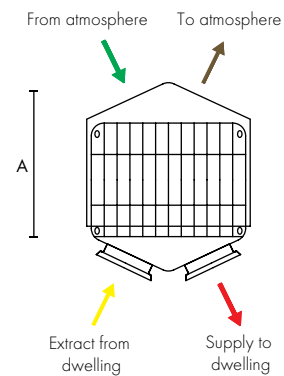

IP Unit

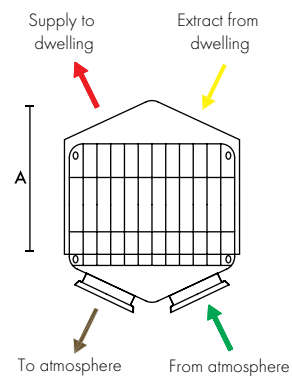

Dimensions (mm)

EP & IP Unit

Hole opening: 610 x 381mm

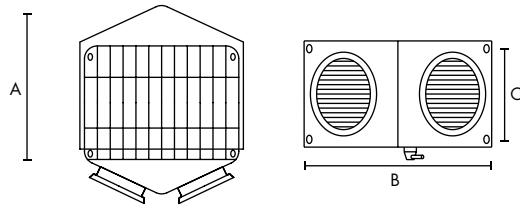

A	B	C
480-750	600	340

Weight: 9kg

Performance

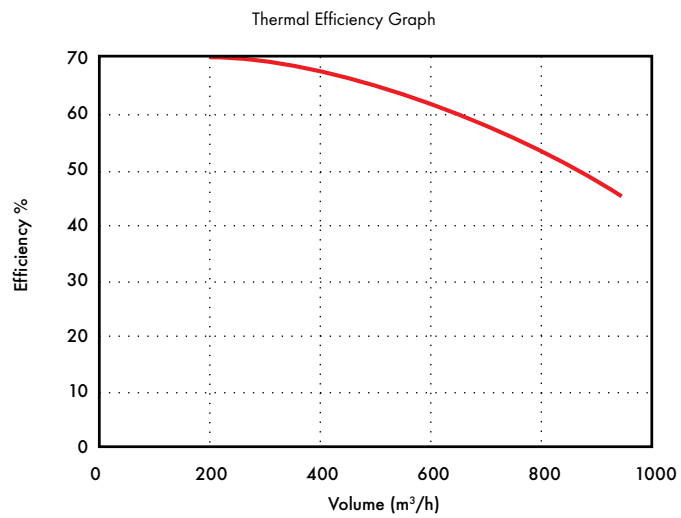
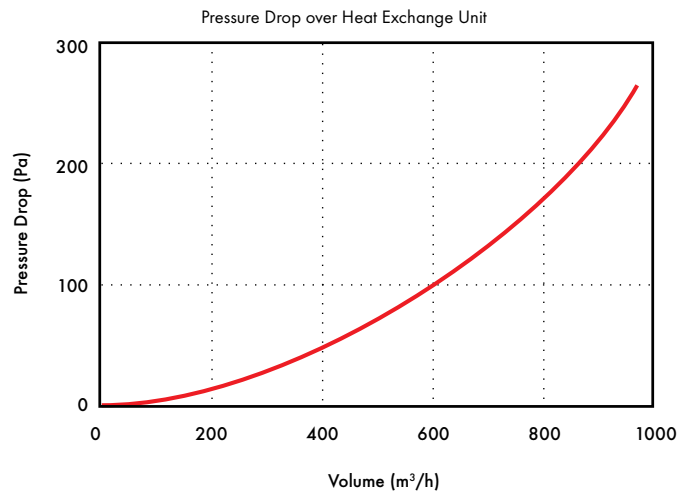

HR500DP

- Passive - no fans
- Lightweight, compact and easy to install
- Up to 70% heat recovery
- Easy to clean

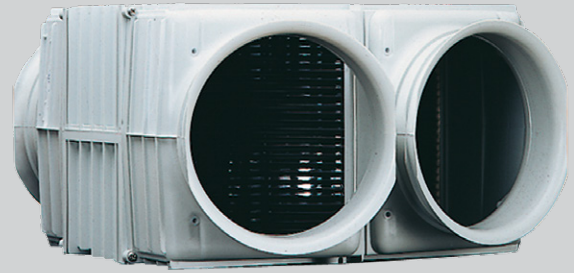

A 'stand alone' heat exchange module which will transfer up to 70% of the outgoing heat to incoming air. Polymeric construction with spigots to suit 200, 250 and 315mm Ø flexible ductwork.

Module accessible for routine cleaning. Condensate outlet provided. Ideal for use in air conditioned environments.

The heat exchanger works at the same high efficiency, automatically keeping a cool room cool.

Performance of the Heat Exchange Unit: At 180l/s achieves 70% temperature efficiency (balanced airflow). Ideal for schools, pubs, offices and leisure industries.

Model

Model	Stock Ref
HR500DP	10538290

Ducting & Fittings



Since 1936, Vent-Axia has been known for providing a complete ventilation solution. This has not changed, and now we offer one of the widest ranges of ancillaries available today.

Vent-Axia

Vent-Axia[®]
Lo-Carbon[™]
**Approved
Installer**

	A1 Fire-Rated Ducting Kit	G:3-G:4
	Uniflexplus+ RV Adjustable Valve	G:5-G:8
	Acoustic Residential Purge Ventilator	G:9-G:10
	Vent-Axia Pure Air	G:11-G:12
	Wholehouse Attenuators	G:13-G:14
	Universal Roof Vents	G:15
	Pull-out System Hood	G:16
	Arterial Duct System	G:17-G:18
	Uniflexplus+ Semi-Rigid Duct System	G:19-G:20
	Internal Fit Wall Kit	G:21
	Low Resistance Inlet/Outlet Air Brick	G:22
	Ducting & Accessories	G:23-G:30
	Galvanised Spiral Wound Ducting	G:31
	Fire Stopping - Round and Flat Ducting	G:32
	100mm & 150mm Accessories	G:33-G:36

A1 Fire-Rated Ducting Kit

- "Telescopic" grille, providing flexibility during installation, accommodating variations in facade
- Built-in weather protection with angled grilles to promote run off
- Precautionary drainage holes
- Compliant with Approved Document B
- Compliant with Building (Scotland) Technical Handbook 2019
- Available in a choice of styles to suit new build and retrofit projects

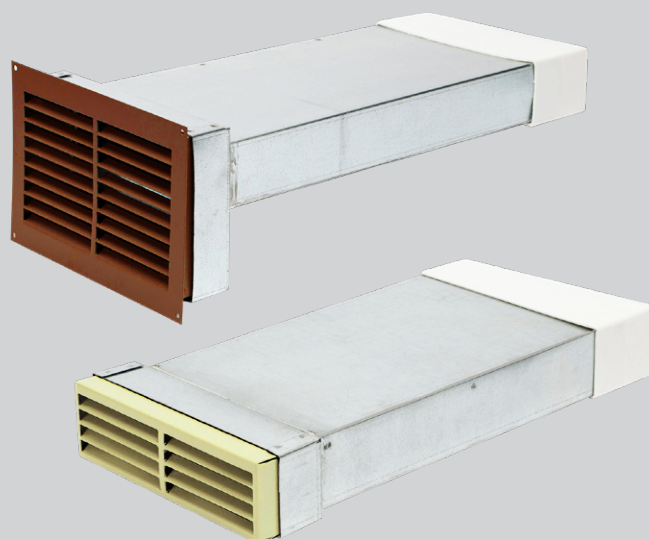

Fire rated ductwork improves the safe operation of ventilation systems by minimising the chance of fire spread. Effective fire resilient insulation acts as a barrier between ducts, to slow down or prevent the passage of flames and smoke around the building.

A1 Fire-rated metal ducting kits, delivered as one piece, to allow for ease of installation, saving time on site. Perfect for multi-storey developments which require all materials forming part of the external wall to be made from non-combustible materials.

Models

A1 Fire-rated ducting kit 204x60

Model	Colour	Stock Ref.
Single Grille	Terracotta RAL 8004	498264
Single Grille Flanged	Terracotta RAL 8004	498265
Double Grille	Terracotta RAL 8004	498266
Double Grille Flanged	Terracotta RAL 8004	498267
Single Grille	Cotswold Stone RAL 1001	498270
Single Grille Flanged	Cotswold Stone RAL 1001	498271
Double Grille	Cotswold Stone RAL 1001	498272
Double Grille Flanged	Cotswold Stone RAL 1001	498273

A1 Fire-rated ducting kit 220x90

Model	Colour	Stock Ref.
Double Grille	Terracotta RAL 8004	498268
Double Grille Flanged	Terracotta RAL 8004	498269
Double Grille	Cotswold Stone RAL 1001	498274
Double Grille Flanged	Cotswold Stone RAL 1001	498275

Performance

Single Grille

Model Range	l/s	Pressure (Pa)	
		Supply	Extract
Single Grille	10	0.17	0.17
	20	0.8	0.18
	30	9	5
	40	25	17
	50	39	22
	60	60	38
	70	92	50
	80	125	77
	90	-	99
	100	-	112

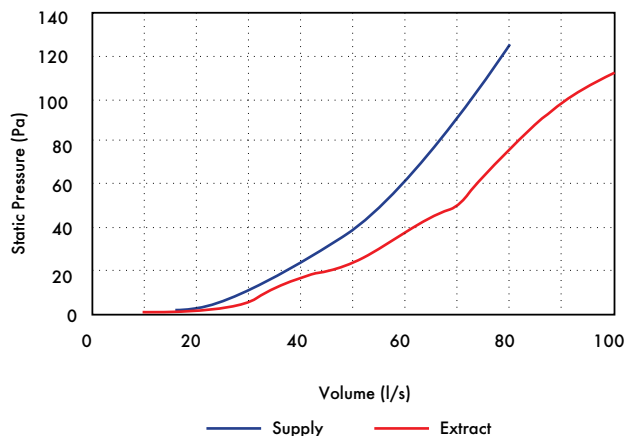

Double Grille

Model Range	l/s	Pressure (Pa)	
		Supply	Extract
Double Grille	10	0.16	0.14
	20	0.19	0.146
	30	0.33	0.146
	40	3.18	1.48
	50	7.9	4
	60	12.35	7.5
	70	16.28	9.9
	80	28	15
	90	36	21
	100	43	25
	110	50.9	30
	120	58	42

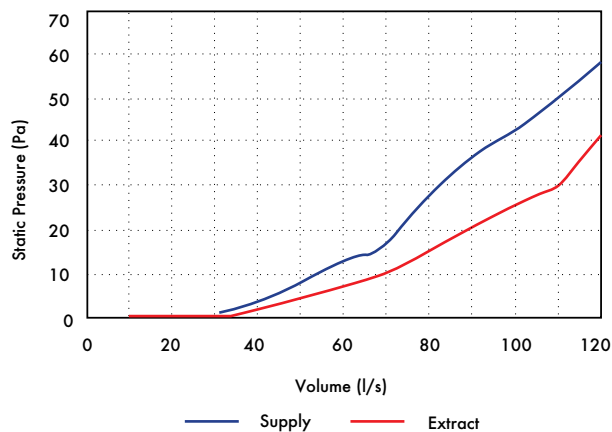

Dimensions (mm)

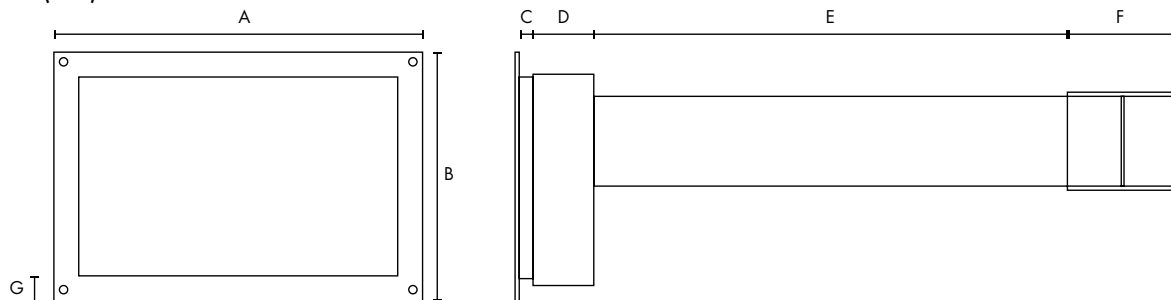

Model	Duct Size	A	B	C	D	E	F	G
Double Grille Flanged	204 x 60 / 220 x 90	245	165	10	40	276	74	15
Double Grille	204 x 60 / 220 x 90	220	141	10	40	276	74	-
Single Grille Flanged	204 x 60 / 220 x 90	245	90	10	40	276	74	15
Single Grille	204 x 60 / 220 x 90	220	66	10	40	276	74	-

Uniflexplus+ RV Adjustable Valve

- One valve for air supply and extraction: suitable for up to 21l/s
- Easy to adjust: 26 lockable positions for setting the air volume
- Excellent performance: the lowest noise and pressure drop values
- Same appearance for each volume of air: external dimensions stay the same irrespective of the selected setting
- Low turbulence airflows: prevents accumulation of dirt around the valve
- Flexible installation for all types of air ducts with connection Ø116 or Ø125
- Easy to clean: no need to remove the valve base
- Multiple designs available to suit various interior styles



Adjusting and locking

The Uniflexplus+ air distribution system has been designed to make installing and adjusting ventilation as quick and as easy as possible. With the Uniflexplus+ RV adjustable valve, the supply and extraction of air can be set and locked at fixed volumes in an instant.

The Uniflexplus+ RV is easy to install, even in suspended ceilings (with the aid of the special collar). The valve is also easy to maintain, as the base of the valve does not need to be removed from the ceiling. The air volume is adjusted entirely in the interior of the valve. This means that the external dimensions – and therefore the appearance – of the valves are always the same.

Airtight and quiet

Uniflexplus+ is well known for its airtight connection without the use of mounting aids. Uniflexplus+ RV combines this with unique noise performance levels. Thanks to very low resistances, it is possible to meet the highest requirements in terms of comfort. If necessary, 120° of the supply/extraction opening can be blocked. In addition, the adjustable valve contains antistatic and antibacterial additives and is UV-resistant.

Different versions

A great deal of attention has been devoted to the design of the adjustable valve and the materials used in it. It has an elegant appearance, with three different designs to suit various interior styles (RV 125, RVG 125 & RVV 125).

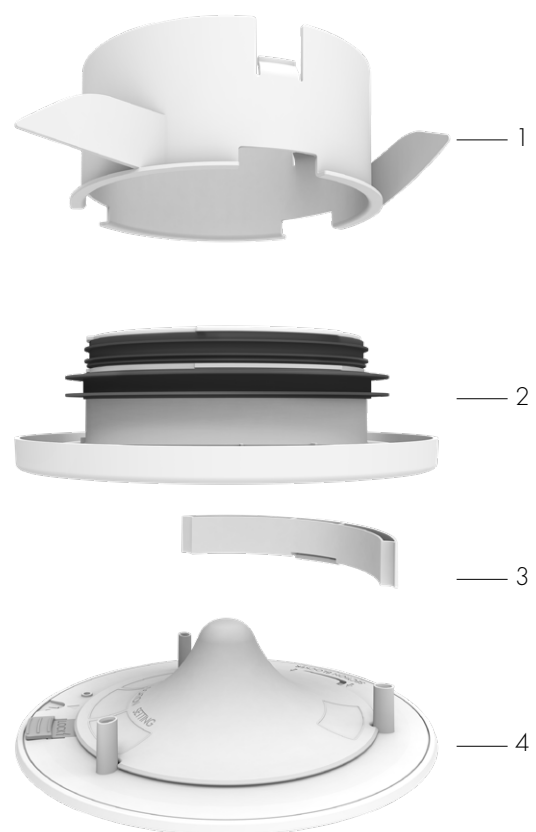

1. Collar (Accessory: RVK)
2. Base
3. Blanking plate (Accessory: RVB)
4. Regulating cone

Models



Adjustable Round Valve
Model
RV 125



Adjustable Round Valve Large
Model
RVG 125



Adjustable Square Valve
Model
RVV 125

Accessories



Stock Ref
479372
Collar
Model
RVK

Stock Ref
479376



Stock Ref
479373
Blanking Plate*
Model
RVB

Stock Ref
479377

*Not suitable for RVV 125 model

Specification

Model	Weight (g)	Colour	Material
RV 125	230	RAL 9003	ASA
RVG 125	410		ASA, powder-coated ALU
RVV 125	450		

Dimensions (mm)

Front view
RV 125 / RVG 125

RVV 125

Side view
(Based on drawing of RV 125)

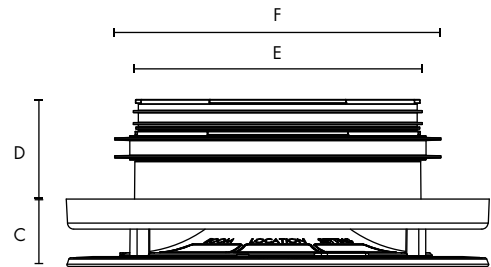
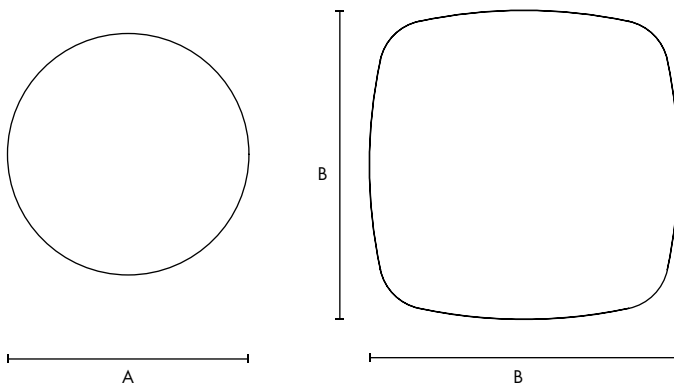

AØ	B	C	D	EØ	FØ
170/215	215	27	40	116	125

Performance graph for Uniflexplus+ RV: Air supply

For each valve setting, the noise and pressure drop performance characteristics are shown in relation to the various air volumes.

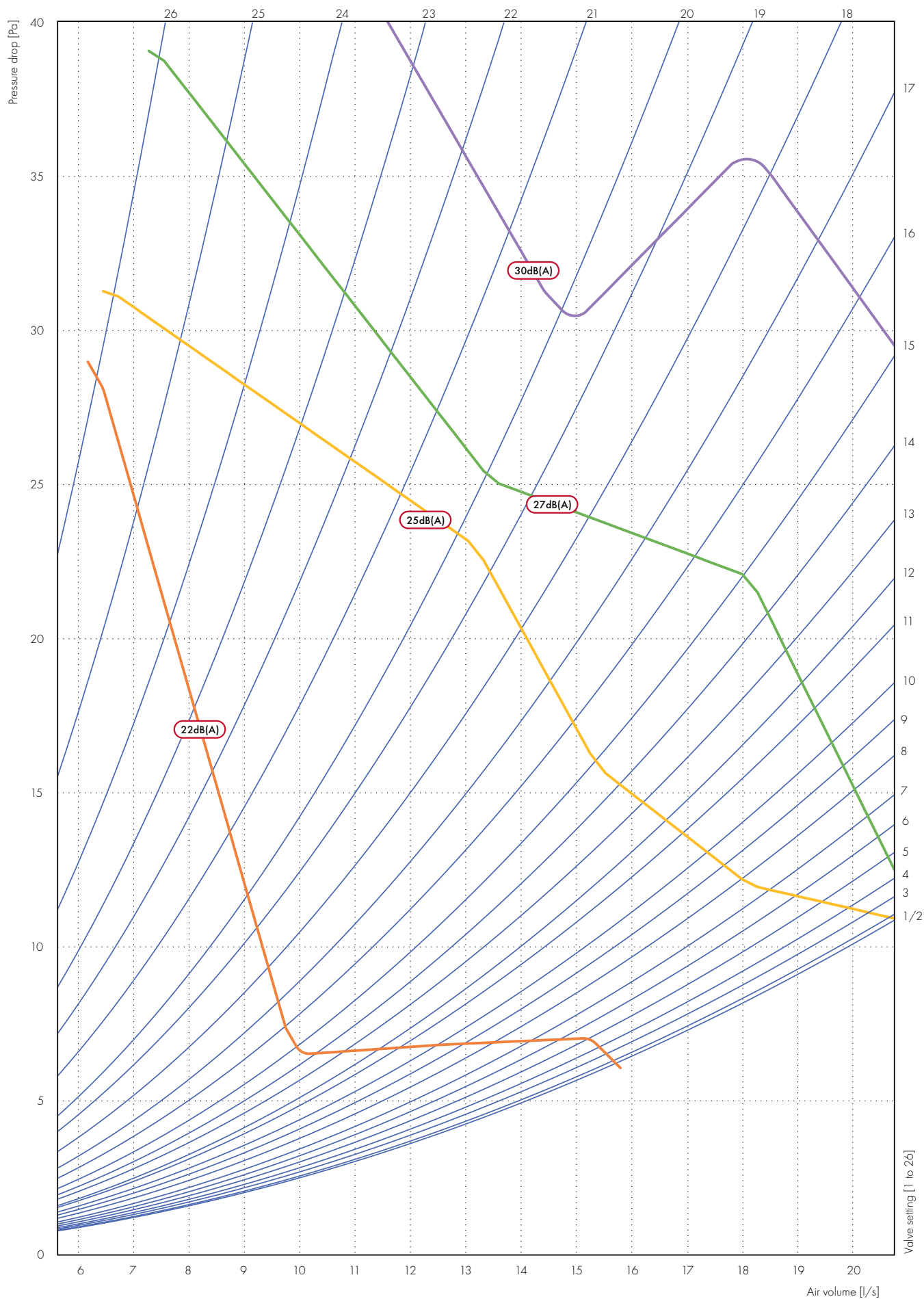

Tested in accordance with: EN ISO 5135:1999

Performance graph for Uniflexplus+ RV: Air extraction

For each valve setting, the noise and pressure drop performance characteristics are shown in relation to the various air volumes.

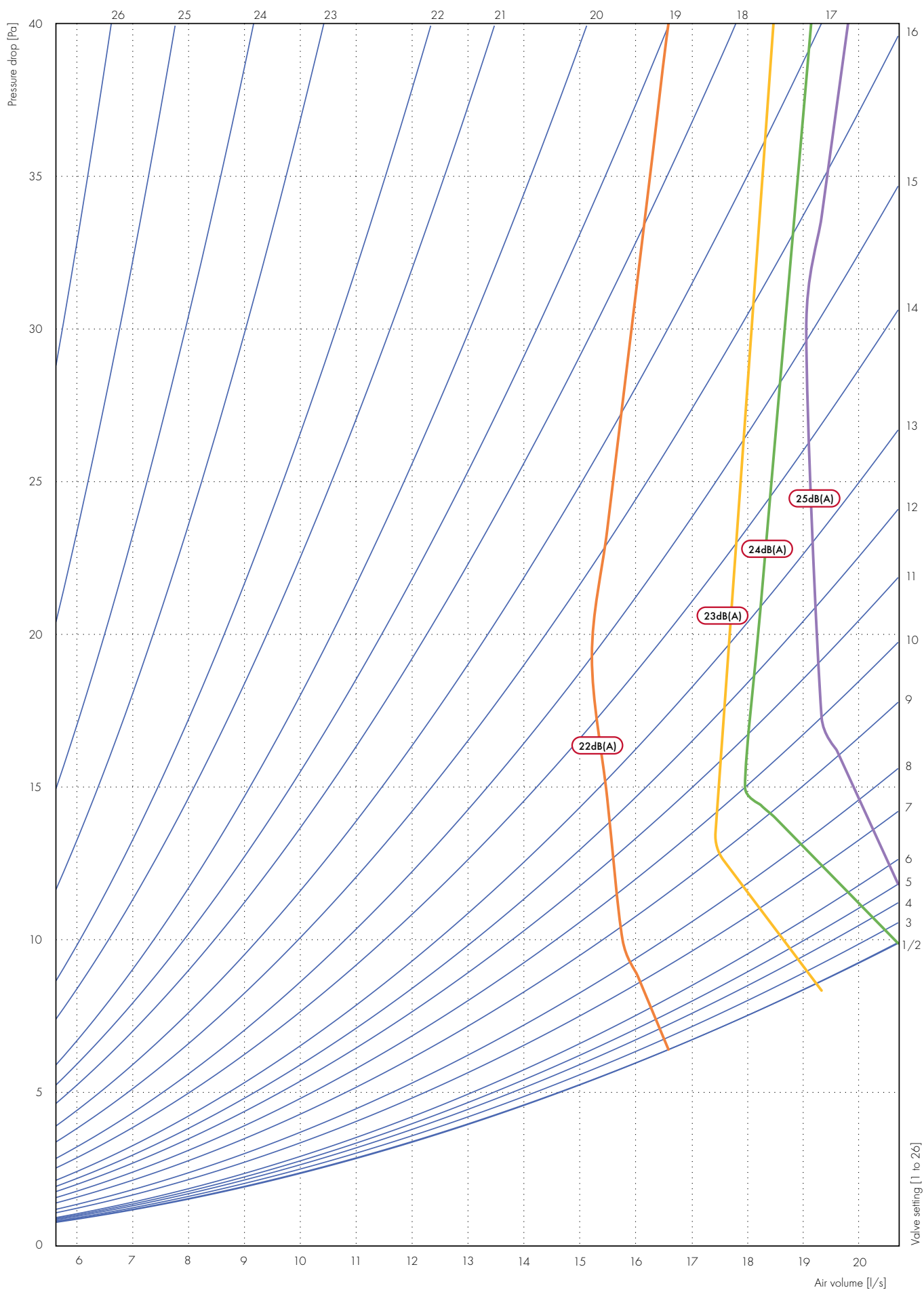

Tested in accordance with: EN ISO 5135:1999

Acoustic Residential Purge Ventilator

- Rapid local extract
- Satisfies Part F purge requirements
- Acoustically treated for low noise
- Helps to reduce overheating
- Can be used in conjunction with MVHR and MEV units or as standalone system
- 220x90 or 250 diameter spigots
- Low profile design
- Easy setup
- Energy efficient EC fan
- Variable speed control
- Low maintenance requirement



The Vent-Axia Acoustic Purge Fan is used to rapidly remove indoor pollutants as well as reducing the impact of overheating in residential dwellings, providing a more comfortable and healthy internal environment for home-owners.

The Acoustic Purge Fan can be used in conjunction with a Sentinel Kinetic MVHR unit or independently via a separate switched live connection or 0-10V external sensor input. The Acoustic Purge Fan can be installed in habitable rooms to satisfy Approved Document F Purge requirements (4 air changes per hour). The unit can be installed in conjunction with controllable duct dampers and/ or background ventilators to manage the supply air into the dwelling under purge operation.

The Acoustic Purge Fan is specially treated with acoustic foam to reduce breakout and induct noise, ensuring end-user comfort during operation. As well as boasting a low-profile design, the unit utilises 220x90 spigots to allow easy use of flat ducting in tight void spaces in apartments.

Model

Model	Stock Ref
Acoustic Purge Fan	477988
Acoustic Purge Fan XL	479829

Accessories

Model	Stock Ref
Remote Speed Control	10520602
Trickle/Boost Controller	475775

Dimensions (mm)

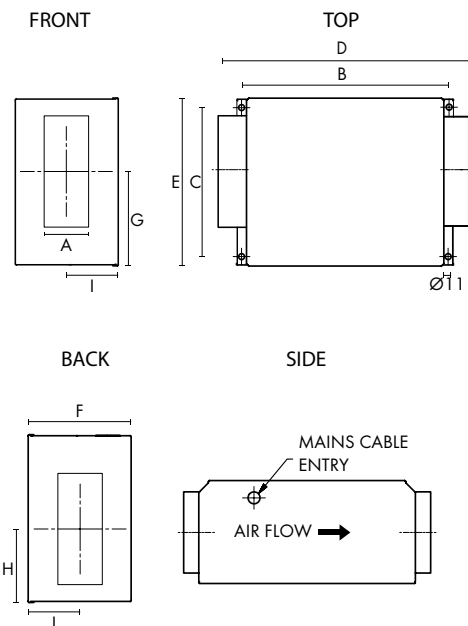

Stock Ref	Spigot	A	B	C	D	E	F	G	H	I	kg
477988	220x90	85	380	275	456	310	191	165	145	103.5	7.5
479829	250Ø	250	435	330	511	364	287	182	122	143	13

Performance

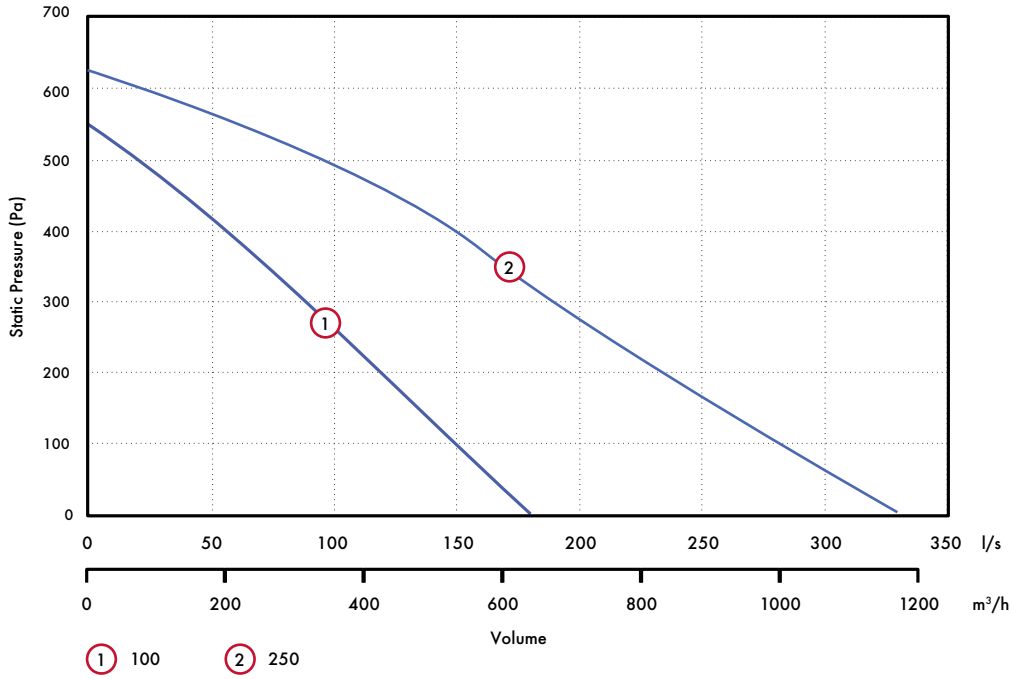

Sound Data

Acoustic Purge Fan

Speed	Test mode	Octave Band (Hz) Sound Power Levels, dB								dB(A) @	
		63	125	250	500	1k	2k	4k	8k	LwA	3m
25%	Inlet	35	30	34	32	26	20	18	24	32	15
	Outlet	36	32	36	34	33	28	20	23	37	19
	Breakout	37	34	31	28	24	18	18	23	30	10
50%	Inlet	40	38	51	47	41	38	31	26	48	31
	Outlet	40	44	57	51	50	49	43	31	56	38
	Breakout	43	46	50	46	43	39	32	27	48	27
80%	Inlet	45	45	60	60	52	49	44	40	59	42
	Outlet	50	50	68	65	61	61	56	49	68	50
	Breakout	64	53	57	58	54	50	47	45	59	39
100%	Inlet	55	46	60	61	53	50	45	41	60	43
	Outlet	53	51	65	66	62	63	57	51	68	51
	Breakout	56	54	57	60	56	52	49	47	61	41

Acoustic Purge Fan XL

Speed	Test mode	Octave Band (Hz) Sound Power Levels, dB								dB(A) @	
		63	125	250	500	1k	2k	4k	8k	LwA	3m
25%	Inlet	48	49	42	38	35	24	24	29	40	22
	Outlet	47	46	41	37	41	29	24	29	42	24
	Breakout	42	42	37	31	29	26	25	31	40	19
50%	Inlet	55	57	65	58	49	43	45	38	57	39
	Outlet	53	57	62	58	54	55	51	36	59	41
	Breakout	52	48	53	43	37	36	34	30	48	27
80%	Inlet	63	65	69	76	62	54	53	49	71	54
	Outlet	63	66	69	72	69	68	62	55	72	54
	Breakout	54	56	57	57	48	46	45	36	57	36
100%	Inlet	68	71	72	80	68	62	59	56	76	58
	Outlet	68	71	70	78	75	75	68	63	78	60
	Breakout	61	63	62	62	55	54	52	45	63	42

Wiring Diagram

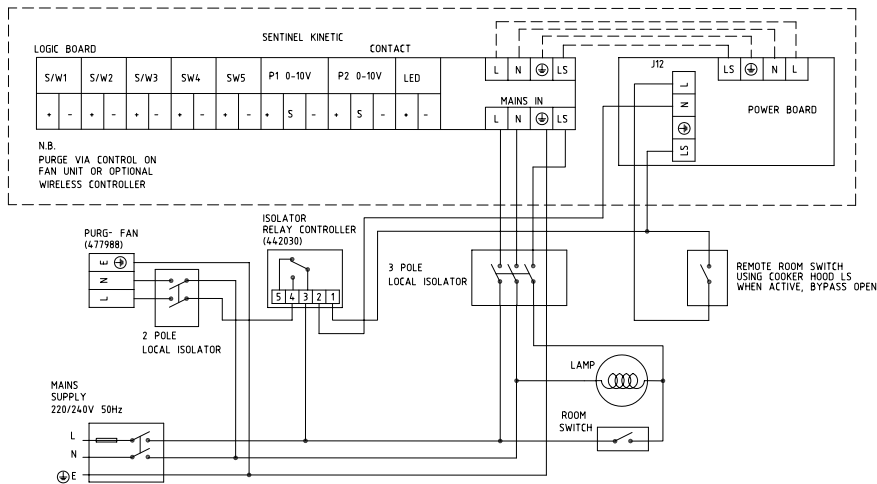

Vent-Axia Pure Air

- Removes NOX and other gases
- Removes particles down to PM2.5
- Offers multiple spigot options
- Low pressure drop
- Easy to install with mounting brackets
- Conforms to international air quality guideline limits
- Easy installation & maintenance
- Various sizes to suit residential or commercial applications
- Provides induct noise attenuation
- Insulating jackets available
- New compact unit available



What is it?

The Vent-Axia Pure Air combines particulate and gas filters to remove pollutants prior to entering residences and commercial buildings through mechanical ventilation and heat recovery systems. The Vent-Axia Pure Air is designed to bring outdoor air pollutant levels within the guideline exposure limits as set out in the World Health Organisation Air Quality Guidelines and the CAFE Directive prior to entering an occupied space.

Indoor air quality (IAQ) is becoming increasingly important with properties being built in urban, industrialised areas. The Vent-Axia Pure Air offers a complete filtration solution with a range of specifiable products that meet planning obligations and refine traditional filtration, leaving home owners with confidence in their heat recovery systems.

What does it do?

The Vent-Axia Pure Air sets the benchmark for high level filtration. It targets pollutants generated outside of the home, by traffic and industrial processes, and reduces these before supplying the air into the dwelling.

The Vent-Axia Pure Air filter is fitted to the intake airflow and incorporates two types of filtration:

- Enhanced activated Carbon which removes unpleasant odours and harmful gasses such as Nitrous Oxide (NO₂).
- ISO 65% Coarse (G4) or ePM2.5 (F7) particulate filters which can remove tiny airborne contaminants such as pollen, bacteria and even PM2.5 diesel particulates.

The combination of MVHR and Vent-Axia Pure Air filtration offers the ideal indoor environment.

Unit Specification

The Vent-Axia Pure Air is manufactured from 1.2mm Galvanised Steel together with suitable sealing for particulate and gas filters. Access is available on both sides via bolted lift off panels. Various round and rectangular transformation spigots are available to suit ductwork systems for both domestic and commercial duct work.

Filter Specification

Particulates, PM10, PM2.5

A new ISO filtration standard has come into force. The test method has changed so direct comparisons between EN779 2012 and ISO 16890 cannot be drawn. Below is a guide to the filter efficiencies:

ISO 16890	EN779
45% Coarse	G3
65% Coarse	G4
ePM10 50%	M5
ePM2.5 70%	F7

Pollutant Gases, NO₂, SO₂, O₃, VOC

The gas stage filters in the Vent-Axia Pure Air are designed to achieve a minimum contact time suitable for the removal of pollutant gases at the rated airflow. A specially formulated activated carbon and chemical mix acts upon pollutant concentrations common in dirty city air, reducing them below guidelines set by current legislation.

Unit Configuration

Standard Gas Filter Unit

Replaceable ePM2.5 or ePM10 Filters

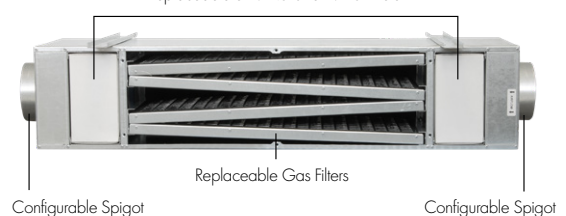

Compact Gas Filter Unit

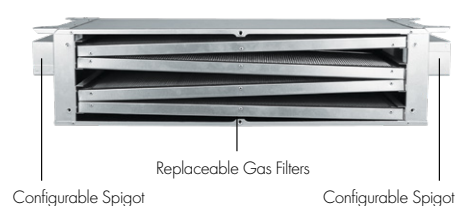

Accessories

Model	Stock Ref
50 l/s insulating jacket	PAJAC-50
100 l/s insulating jacket	PAJAC-100
Spare ePM2.5 filter	PAFIL-25
Spare ePM10 filter	PAFIL-10
Spare gas filter	PAFIL-NO2

Models

Model Range	Stock Ref	Airflow l/s	Intake Spigot (mm)*	Exhaust Spigot (mm)*	Filter Types	Clean Filter Pressure Drop (Pa)	Approximate Unit Weight (kg)
Standard Gas Filter Unit	PA50-125125-25	50	125Ø	125Ø	PM2.5	100	25
	PA50-204204-25	50	204x60	204x60	PM2.5	100	25
	PA50-125125-10	50	125Ø	125Ø	PM10	45	25
	PA50-204204-10	50	204x60	204x60	PM10	45	25
	PA100-150150-25	100	150Ø	150Ø	PM2.5	100	49
	PA100-220220-25	100	220x90	220x90	PM2.5	100	49
	PA100-150150-10	100	150Ø	150Ø	PM10	45	49
	PA100-220220-10	100	220x90	220x90	PM10	45	49
	PA200-200200-10	200	200Ø	200Ø	PM10	45	96
Compact Gas Filter Unit	PAC50-125	50	125Ø	125Ø	PM10	45	23
	PAC50-150	50	150Ø	150Ø	PM10	45	23
	PAC50-204	50	204x60	204x60	PM10	45	23
	PAC50-220	50	220x90	220x90	PM10	45	23
	PAC100-125	100	125Ø	125Ø	PM10	45	45
	PAC100-150	100	150Ø	150Ø	PM10	45	45
	PAC100-204	100	204x60	204x60	PM10	45	45
	PAC100-220	100	220x90	220x90	PM10	45	45

*Airflow may be reversed through the unit to offer alternative spigot options.

Example Stock Ref:

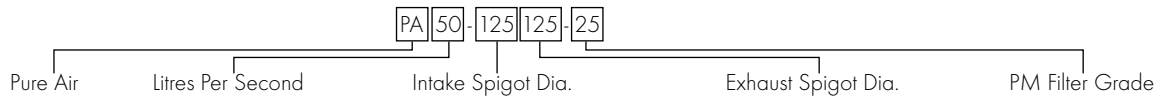

Dimensions (mm)

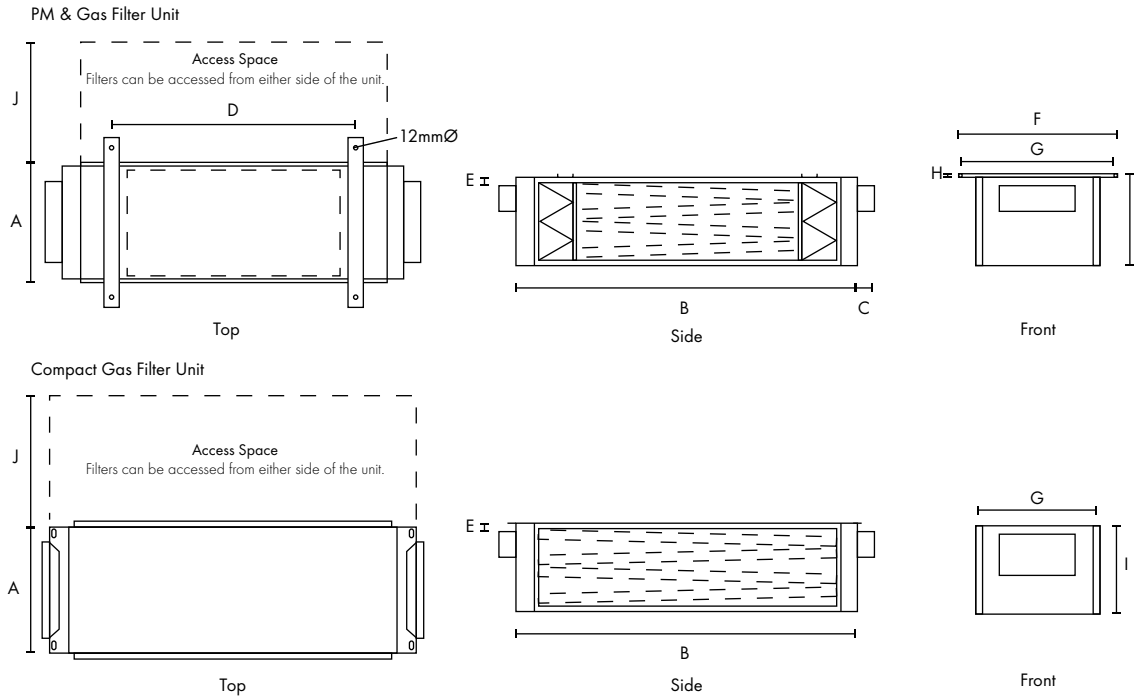

Model Range	Airflow l/s	A	B	C	D	E	F	G	H	I	J
Standard Gas Filter Unit	50	320	980	50	700	25	435	405	10	220	325
	100	620	980	50	700	25	730	700	10	220	325
	200	620	980	50	700	110/85	730	700	10	420	650
	300	620	980	50	700	160	730	700	10	630	960
Compact Gas Filter Unit	50	320	690	-	-	25	-	260	-	180	325
	100	620	690	-	-	25	-	560	-	180	325

Wholehouse Attenuators

- Reduces induct noise
- Variety of sizes to suit specified noise requirements
- Compatible with both 204x60mm² and 220x90mm² rectangular ductwork
- Central and offset spigot options to suit each installation
- Rigid galvanized steel construction
- Easy installation
- Suitable for almost any ventilation system
- Low pressure loss



The Vent-Axia Wholehouse Attenuator has been developed to reduce induct noise in both residential and commercial ducting systems.

Technical Details

The Wholehouse Attenuator is compatible with either 204x60mm² or 220x90mm² ducting. It also offers two spigot options to suit the installation and design requirements. The Wholehouse Attenuator is available with either a standard centralised spigot or, for instances when the ducting is installed flat to a concrete slab, an offset spigot. As well as saving the need for additional ducting components, this allows for a much easier and quicker installation.

Noise Reduction

Offering excellent sound reduction over a range of frequencies, the Wholehouse Attenuator is available in two lengths depending on the noise suppression requirements. For MVHR systems the attenuator can be fitted on the supply side to habitable rooms, reducing airborne in-duct noise. For MVHR and extract-only systems, the attenuator may be placed on the extract side to limit 'crosstalk' through ductwork between rooms.

Models

Attenuator with Central Spigot

Model	Stock Ref
204x60 Duct 620mm Length	477369
204x60 Duct 920mm Length	407915
204x60 Duct 1220mm Length	407916
220x90 Duct 620mm Length	477370
220x90 Duct 920mm Length	407920
220x90 Duct 1220mm Length	407921

Attenuator with Offset Spigot

Model	Stock Ref
204x60 Duct 620mm Length	477371
204x60 Duct 920mm Length	475427
204x60 Duct 1220 Length	475428
220x90 Duct 620mm Length	477372
220x90 Duct 920mm Length	475429
220x90 Duct 1220mm Length	475430

Acoustic Flexible Ducting

Model	Stock Ref
125mmØ Duct 1m Length	443793
150mmØ Duct 1m Length	443274

Dimensions (mm)

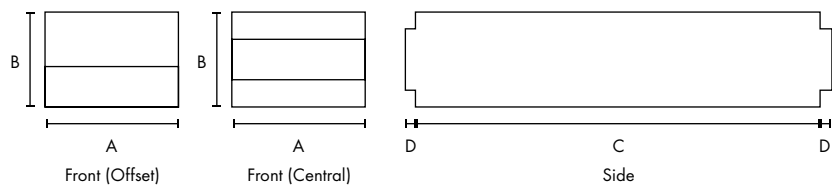

Model	Stock Ref	A	B	C	D	kg
204x60 Duct 620mm Length	477369/477371	196	125	620	50	10
204x60 Duct 920mm Length	407915/ 475427	200	120	920	50	13
204x60 Duct 1220mm Length	407916/475428	200	120	1220	50	17
220x90 Duct 620mm Length	477370/477372	207	148	620	50	10
220x90 Duct 920mm Length	407920/ 475429	210	145	920	50	14
220x90 Duct 1220mm Length	407921/475430	210	145	1220	50	17

Acoustic Performance

Model	Stock Ref	Insertion Loss (dB)							
		63	125	250	500	1k	2k	4k	8k
204x60 Duct 620mm Length/ 220x90 Duct 620mm Length	477369/477370/ 477371/477372	3	4	7	13	21	38	45	33
204x60 Duct 920mm Length	407915/475427	0.3	3.2	11.6	24.2	38	49.1	50.3	36.4
204x60 Duct 1220mm Length	407916/475428	0.3	1.8	14.1	21.3	35.4	46.9	50.4	36.4
220x90 Duct 920mm Length	407920/475429	7.3	10.2	13.1	26.2	34.9	47.6	52.2	38.9
220x90 Duct 1220mm Length	407921/475430	1.2	7.4	18.6	30.2	39.1	51	45.2	38.6
125mmØ Duct 1m Length	443793	5.5	11.5	17	19.9	19.1	25.6	20	21.6
150mmØ Flexible Duct 1m Length	443274	-1.2	10.6	19	16.8	15.7	22.2	15.7	17.6

Pressure Loss

Model	Duct Size (mm)	Volume (l/s)	Pressure Loss (Pa)
Attenuator	204x60	15	6
		30	10
		60	25
		80	41
Attenuator	220x90	15	6
		30	10
		60	22
Acoustic Flexible Ducting (1m)	125	15	2.8
		30	8.8
		60	19.2
Acoustic Flexible Ducting (1m)	150	15	1.7
		30	6.4
		60	13.8
		80	28.4

Universal Roof Vents

- Models available for both pitched and flat roof types
- Complies with Building Regulations
- Suitable for most installations
- Corrosion resistant and weather proof
- Compatible with both mechanical and natural ventilation systems
- Three colours available for pitched roof vents

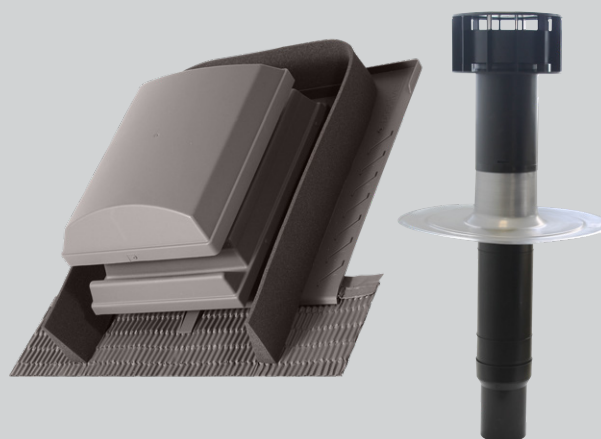

Wholehouse ventilation systems require termination to the external atmosphere, often through the roof. To ensure that the ventilation system is able to achieve its optimum level of performance, it is important that a suitable roof termination product is installed.

With this in mind, Vent-Axia is pleased to offer a range of Universal Roof Vents; including products suitable for both pitched and flat roof types.

A selection of colours and sizes should ensure that our range offers a product suitable for most residential applications with a pitched or flat roof. Pitched roof vents are available in a variety of colours as detailed in the Specification Table - custom colour and textured vents to match your exact needs are also available at an extra charge. Please contact our Technical Support team for more details.

Models

Universal Roof Vent suitable for Pitched Roofs

Manufactured in the UK, these products have been specifically developed for use with both natural and mechanical ventilation systems.

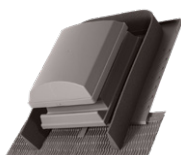

All models have been independently tested by the BRE to BS476 Part 3: 2004 and have been awarded an AA classification - the highest possible. Thus they can be installed without restriction on any pitched roof.

All models have low resistances to airflow (see table) and incorporate condensation grooves to prevent any condensate running back down the duct. Universal Roof Vents are designed to resist the ingress of deluge and driving rain. Universal Roof Vents (pitched roof models) are suitable for roof pitches between 20° and 60°.

The pitched roof vents are available as a 'tiled' roof vent to fit alongside most traditional roof tiles, as well as a 'slate' version which can be easily cut down to fit alongside all traditional roof slates.

Stock Ref	Tile Type	Spigot mm	Colour	Airflow Resistance (Pa) at l/s				
				14	28	56	83	140
407329	Universal*	125	Red	1.1	4.1	16.8	N/A	N/A
407330	Universal*	125	Brown	1.1	4.1	16.8	N/A	N/A
407331	Universal*	125	Grey	1.1	4.1	16.8	N/A	N/A
407332	Universal*	150	Red	0.3	1.0	4.2	9.5	27.4
407333	Universal*	150	Brown	0.3	1.0	4.2	9.5	27.4
407334	Universal*	150	Grey	0.3	1.0	4.2	9.5	27.4
407335	Slate	125	Slate Blue/Black	1.1	4.1	16.8	N/A	N/A
407336	Slate	150	Slate Blue/Black	0.3	1.0	4.2	9.5	27.4

*Universal Roof Vents are not suitable for the following tile types: Plain, Clay Single Pantiles, Forticrete Centurion, Goxhill Gaelic Tiles, Double Lap or Interlocking Slates. If the Universal Roof Vent does not meet your requirements, please contact our Technical Support team for a bespoke solution

Universal Roof Vent suitable for Flat Roofs

Capped stacks for use in asphalt and built-up felt roofs. Special low air resistance cowl - the pressure/airflow resistance is <1.0 Pascal at 63l/s. The pipework above the roofline is twin walled and incorporates an integral condensation drain. The stack pipe has an integral collar and separate aluminium flange for use with both felt and asphalt roof finishes.



All Vent-Axia Universal Roof Vents have a free area exceeding those required by Building Regulations.

Stock Ref	Colour	Free Vent Area mm ²	Pressure/Airflow Resistance	Dia. mm	Height Above Roof mm	Flange Dia. mm	Depth Below Flange mm
407337	Black	8,400	<1.0	110	300	395	350
407338	Black	12,000	<1.0	131	400	450	350
407339	Black	20,000	<1.0	166	540	450	510

Pull-out System Hood/SELV

- Models available with either a White or Brushed Aluminium trim
- Fits within a 600mm wide aperture (300mm deep)
- Complete with two low energy 9W lamps
- All models are fitted with a metal washable grease filter as standard
- 125mm galvanised duct connection piece
- Integral fire damper in accordance with BRE 398
- Weight: 3.7kg
- SELV hoods allow the distance between the hood and an electric hob to be reduced from 650mm to 550mm



Product

The Pull-out System Hood is designed to fit in a 600mm aperture above a hob. The telescopic hood incorporates two flat removable metal grease filters, two low energy light bulbs and is available with a White or Brushed Aluminium front trim.

The hood contains an integral fire damper in accordance with BRE Digest 398 and is connected to the mechanical ventilation unit by a galvanised steel duct connection piece. When the hood is opened the mechanical ventilation unit goes to boost speed.

Why install a cooker hood?

Steam created during the cooking process can cause moisture to form on walls and furniture. In extreme cases this can lead to mould growth. Strong smells can also be created during cooking and these can spread throughout the dwelling. Cooking oils may be vaporised when frying and this oil can be deposited in areas around the cooker.

The solution

When connected to an MEV or MVHR system, the Pull-out System Hood can be wired in such a way that when the hood part of the unit is pulled out the MEV or MVHR system will automatically switch to boost.

The Pull-out Hood System Hood comes with an integrated 125mm galvanised spigot to allow for connection to the MEV or MVHR system.

SELV hoods allow the distance between the hood and an electric hob to be reduced from 650mm to 550mm.

Models

Model	Stock ref
White	407509
Aluminium	407206
White SELV	474790
Aluminium SELV	474791

Dimensions (mm)

TOP

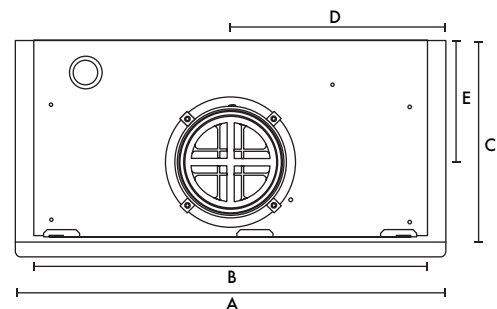

SIDE

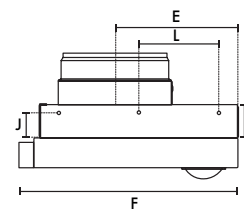

FRONT

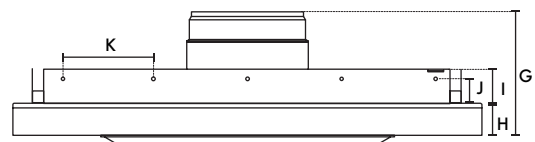

A	B	C	D	E	F	G	H	I	J	K	L
598	570	280	299	126	300	158	41	50	40	120	110

Arterial Duct System

- Reduces installation time
- Can be applied in SAP as a rigid duct system
- Crush resistant semi-rigid duct
- Unique low-resistance manifolds
- Simple installation through joists
- Smooth inner surface with antistatic and antibacterial coating
- Combines the advantages of rigid ducting with the versatility of a semi-rigid system



Arterial System

For use with MVHR systems, the Arterial air distribution system provides a flexible, highly robust solution, which can significantly reduce the installation time when compared to a standard system.

Rigid vs Semi-Rigid Systems

Both traditional duct types have limitations in modern construction. **Rigid systems:** Passing rigid duct through a floor cassette at rightangles to the joists is time consuming and multiple connections increase the risk of leaking ductwork. **Semirigid Systems:** It can often be difficult to accommodate two distribution boxes and multiple semirigid pipe runs in new buildings and the time saving advantages are soon overtaken by the additional cost of materials.

Reduced Installation Time

The VentAxia Arterial range combines the advantages of semirigid and traditional rigid ducting in one simple system. The system is independently tested and can be applied in SAP as a standard rigid system. Drops between floors to/from the MVHR unit remain in rigid PVC, having the advantage of low space usage and low cost. Traversing through joists in a floor cassette is much simpler and faster when using semirigid duct. The secret to the Arterial System is the unique low-resistance distribution plenum (Patent Pending) which is sited between joists allowing connection between semirigid and rigid sections.

100mm Elbow Bend to 90mm

Stock Ref	O/I Ømm	External Dimensions (mm)		
		A	B	C
496741	90/78	119	226	280

Single Spigot Adaptor

Stock Ref	Duct Size	External Dimensions (mm)		
		A	B	C
408872	220x90 to 78Ø	94	258	150

Double Connector Plate

Stock Ref	Duct Size	External Dimensions (mm)		
		A	B	C
408873	220x90 to 78Ø	98	226	66

Single Connector Plate

Stock Ref	Duct Size	External Dimensions (mm)		
		A	B	C
408874	220x90 to 78Ø	98	226	66

Blank Plate

Stock Ref	Duct Size	External Dimensions (mm)		
		A	B	C
408875	220x90 to 78Ø	98	226	26

Reducer

Stock Ref	Duct Size	External Dimensions (mm)		
		A	B	C
408885	120 to 78Ø	129	105	129

Semi-Rigid Ducting

Stock Ref	O/I Ømm	Length m	Coil Ømm	Coil Height	
				mm	kg
406588	90/78	50	1130	250	19.5

Complete System Setup Example

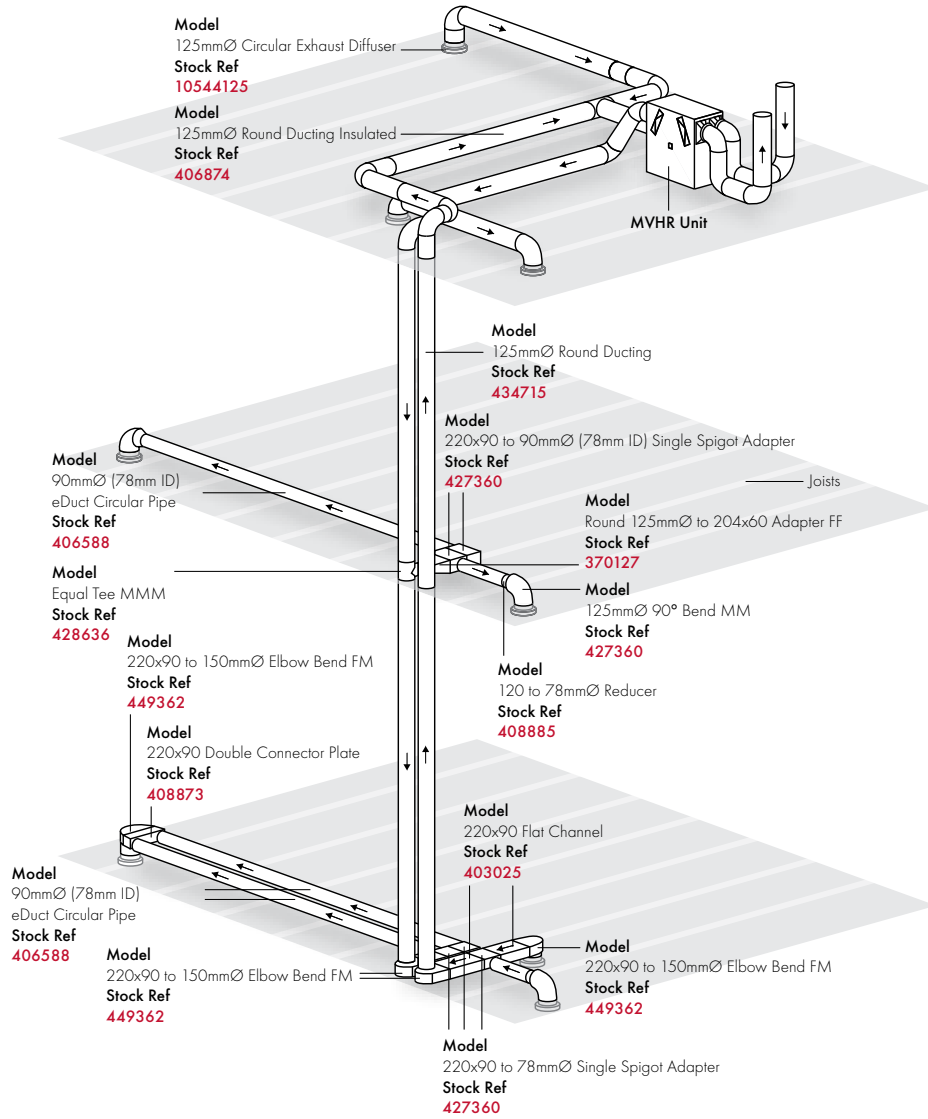

System Configuration Examples

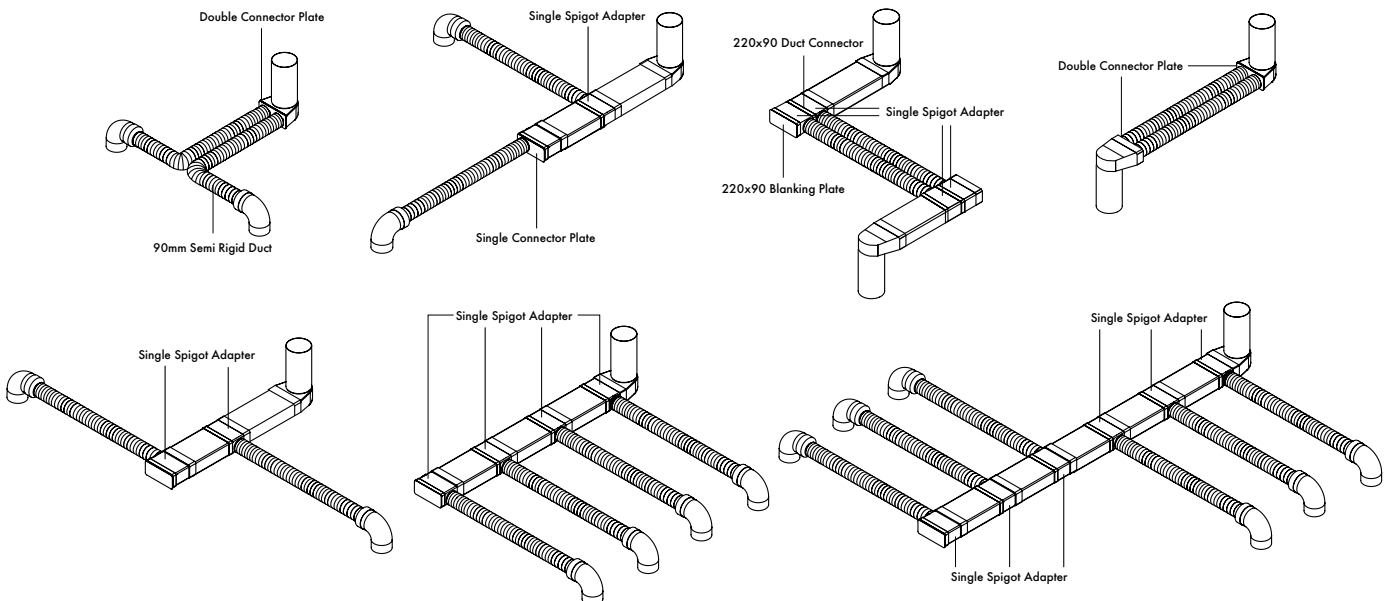

Uniflexplus+ Semi-Rigid Duct System

- Compact, low profile system
- Highly flexible and robust
- Extremely crush resistant
- Quick and easy to install
- PCDB listed
- Suitable for installation in concrete
- Corrosion resistant
- Smooth inner surface with antistatic and antibacterial coating
- Independently tested and accredited for air tightness
- Class D air tightness
- Operating temp.: -20°C to +60°C
- A spigot blanking cap is provided for use with single runs of semi-rigid

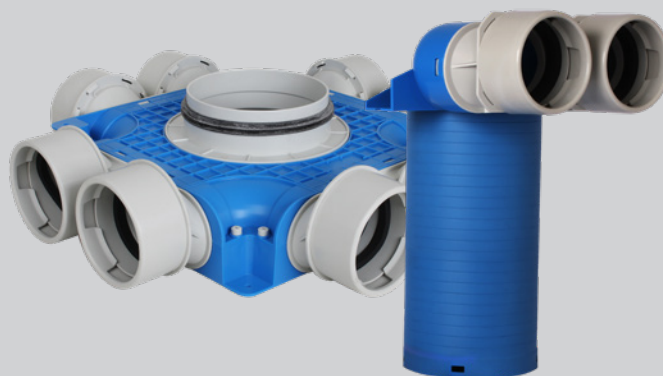

Uniflexplus+ Semi-Rigid Range

The new Uniflexplus+ Semi-Rigid Range sets the standard for easy to install, low profile ducting solutions. The system gives all of the flexibility that semi-rigid ducting provides - without taking up vital space. With minimal components, the system is uncomplicated to ensure a hassle-free, speedy install.

The Uniflexplus+ Semi-Rigid Range is compatible with most wholehouse ventilation systems including the Lo-Carbon Sentinel Kinetic Range (MVHR).

Accessories

Description	Duct Size	Stock Ref
Circular Extract Diffusers	125mmØ	10544125
Duct Knife	Ø90mm	472252
90° Bend	Ø90mm	472253
Coupler	Ø90mm	472254

Description	Model	Duct Size	Stock Ref
Adjustable Round Valve	RV125	125mmØ	479372
Adjustable Round Valve Large	RVG125	125mmØ	479373
Adjustable Square Valve	RVV125	125mmØ	479374
Adjustable Valve Collar	RVK	125mmØ	479376
Adjustable Valve Blanking Plate*	RVB	125mmØ	479377

*Not suitable for RVV125 model

Complete System Setup Examples

The distribution boxes can be mounted vertically on a wall or fixed horizontally onto a ceiling slab to achieve a solution tailored to your need. At a depth of just 90mm, the distribution boxes offer a considerably low-profile solution - they can then be combined with various components to suit on-site needs.

Semi-Rigid ducting is run from distribution boxes and ancillaries to respective rooms in the dwelling. Connecting the Semi-Rigid ducting to components is exceptionally straightforward to allow speedy installation - simply turn the ducting into the spigot until it clicks twice to achieve an airtight mechanical seal.

Rigid or flexible 125mm diameter ducting is then run from the MVHR unit to the distribution box.

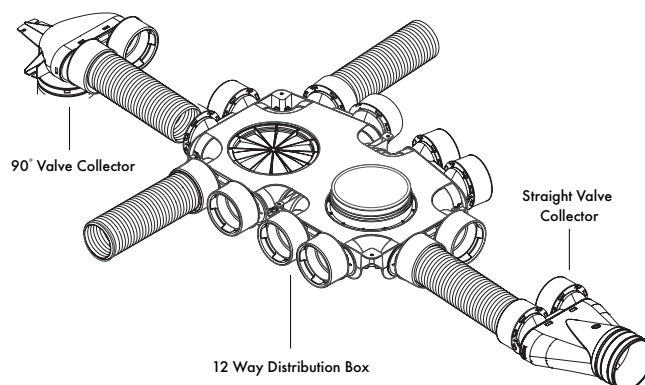
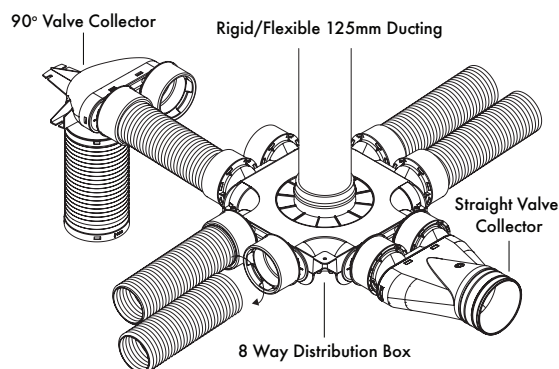

Models

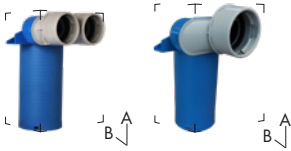

90° Valve Collector

The 90° Valve Collector connects a section of 125mm diameter ducting and turns 90° into 1 or 2 spigots to connect to the semi-rigid - ideal for dropping semi-rigid into ceiling diffusers.

Duct Size	Stock Ref
2xØ90 - Ø125mm	472248
1xØ90 - Ø125mm	472249

Dimensions (mm)

Stock Ref	Curve Ref	A	B	kg
472248				0.9
472249	1	376	300	0.8

Performance

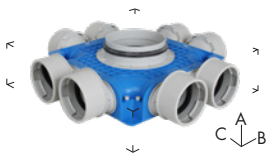
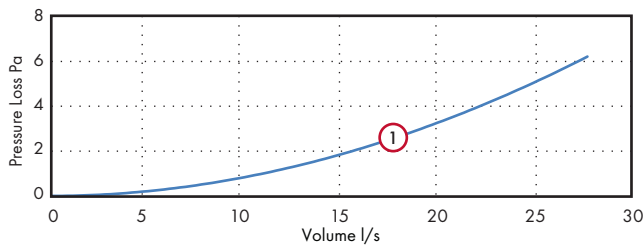

Distribution Box

The low-profile distribution box runs a central spigot of diameter 125mm into a set of either 8 or 12 sub-spigots, depending on requirements. Available with 90mm semi-rigid spigots.

Model	Stock Ref
12xØ90 - Ø125mm	472250
8xØ90 - Ø125mm	472251

Dimensions (mm)

Stock Ref	Curve Ref	A	B	C	kg
472250	1	124	755	520	3.9
472251	2	125	479	479	2.3

Performance

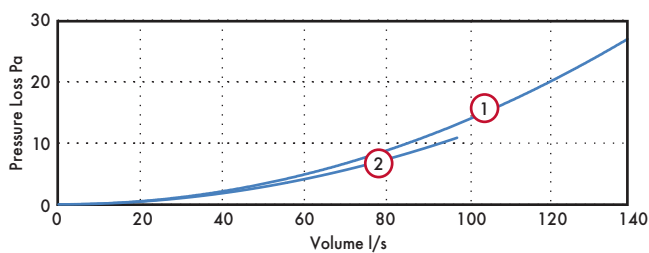

Straight Valve Collector

The straight valve collector takes 125mm ducting and turns it straight into 2 spigots to connect to semi-rigid.

Model	Stock Ref
2xØ90mm - Ø125mm	472262

Dimensions (mm)

Stock Ref	A	B	C
472262	123	311	229



Semi-Rigid Ducting

Suitable for installation in concrete ceilings, suspended ceilings, internal walls, risers or frames, the Semi-Rigid Ducting is double-walled providing optimum flexibility. With an antistatic and antibacterial coating, the internal surface of the Semi-Rigid Ducting is smooth to ensure minimal resistance to airflow. Normally flammable construction material class E, according to EN-13501-1.

Pipe Size	Stock Ref
90mmØ x 50m	406588
90mmØ x 25m	474078

Dimensions (mm)

Stock Ref	Curve Ref	O/I Ømm	Length m	Coil Ømm	Coil Height mm	kg
406588	1	90/78	50	1130	250	19.5
474078	-	90/78	25	1130	125	9.8

Performance

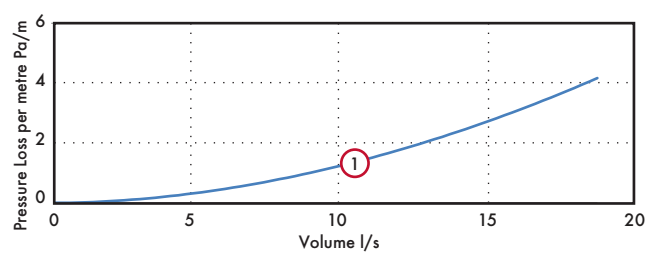

Internal Fit Wall Kit

- Ideal for high-rise applications
- Suitable for 100mm fans
- Quick & easy installation
- Extendable length
- Fits from inside the property
- Reduces water ingress
- Includes low-resistance external grille
- Suitable as a passive air grille
- Covers external break-out

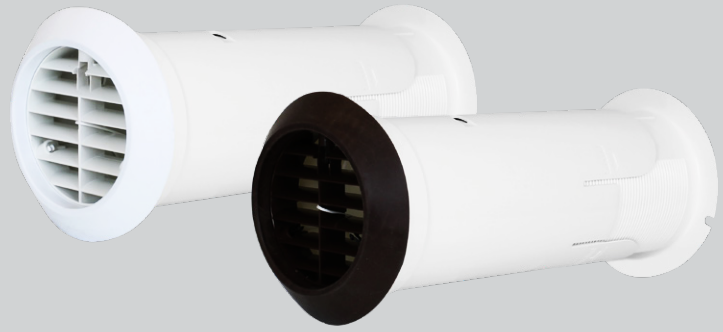

Internal Fit Wall Kit

The Internal Fit Wall Kit is designed to simplify installation and improve the finish of 100mm through the wall installations, also providing an external grille and water ingress protection shroud.

High Rise Buildings

The Wall Kit can be fully installed from inside the building, avoiding the need for scaffolding and significantly reducing the cost and complexity associated with these sites. After core-drilling a 117mm hole, or utilising an appropriate existing hole, the Kit simply pushes through from the inside of the building. Spring pins secure the external grille in position and the external shroud deploys around the grille covering up break-out from the external surface.

Installer Friendly

Quick and easy to install, the Internal Fit Wall Kit cuts down time on site when compared to traditional methods using flexi-duct. Installers no longer need to spend time fixing flexi-duct to fans and grilles using jubilee clips, or going outside to fit the grille. The tubes extend to accommodate wall thicknesses from 225mm up to 390mm and lock into position for a secure fit. The internal flange is also flexible enough to accommodate deviations in the internal surface finish.

Building Regulations

The external grille free area is greater than 90% of the area of the duct making it suitable for continuous running systems as well as for intermittent fans.

Backdraught Shutter

The Internal Fit Wall Kit has optional backdraught shutter models. Particularly useful with intermittent fans, the backdraught shutter will ensure no draughts and gusts come in to the home through the wall kit.

Models

Model	Stock Ref
White External Grille	472318
Brown External Grille	472319
White External Grille with Backdraught Shutter	474779

Dimensions (mm)

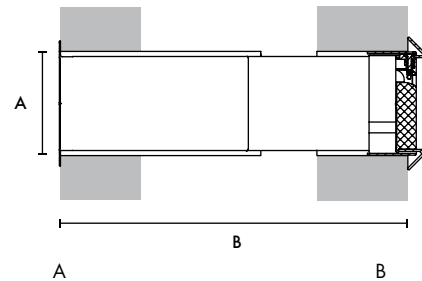

A 117mmØ B 225-390mm

Features

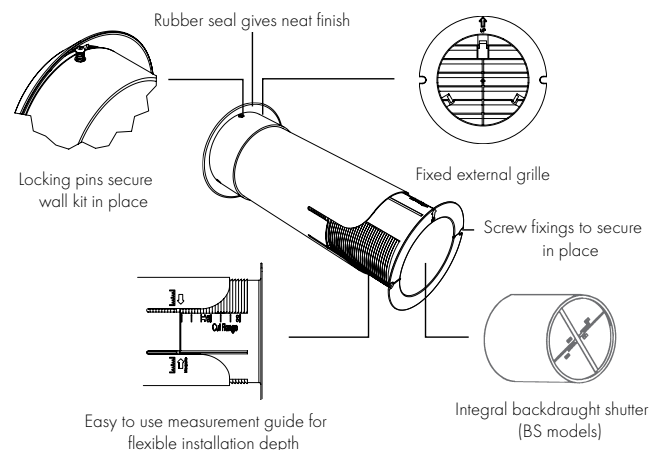

Low Resistance Inlet/Outlet Air Brick

- Provides over 90% free area of duct
- Easier to install than a double air brick
- Guide vanes for improved duct connection
- Optional first fix duct section



Available in five colours, this low resistance air brick has been designed to comply with the latest Building Regulations Approved Document F, which requires a ventilation outlet to achieve a minimum of 90% of the cross sectional area of the ductwork.

Installing a single air brick is much simpler than a double air brick and offers more versatility for locations.

Suitable for installation with round 100mm and 125mm diameter and rectangular 204 x 60mm ducting.

Attaching duct to the air brick is simplified by the use of guide vanes which help locate the duct onto the spigot.

A 500mm section of 204 x 60 duct is available for first fix which ensures that connections are accessible after completion of building works.

Five colour options ensure that the low resistance air brick will be a match for almost any application.

Models

Model	Stock Ref
White	449223
Brown	449224
Cotswold Stone	449225
Grey	449226
Terracotta	449227
1st Fix duct section	403255

500 x 204 x 60

Available Colours



Performance Guide

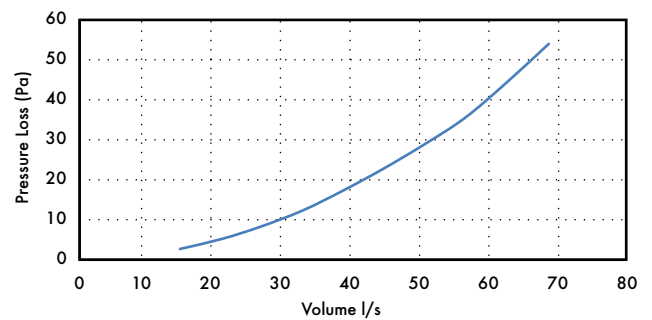

Pressure (Pa)	Volume (m ³ /h)	Volume (l/s)
2.7	53.7	14.9
5.2	75.9	21.1
8.3	97.0	26.9
12.4	119.4	33.2
17.4	141.0	39.2
22.7	162.0	45.0
28.7	183.7	51.0
35.4	205.6	57.1
44.1	227.6	63.2
54.0	250.4	69.6

Dimensions (mm)

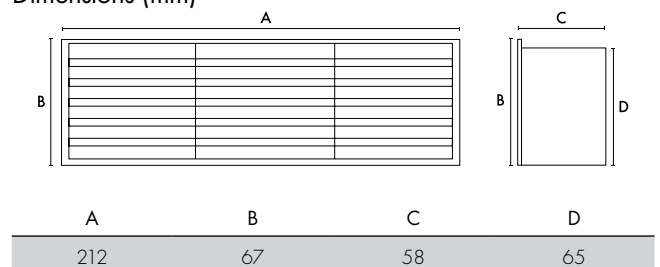

Ducting & Accessories

Flat Channel Ducting Insulated/Uninsulated

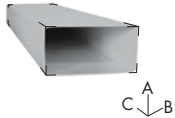

Stock Ref	Duct Size	External Dimensions (mm)			Resistance (Pa) at flow rate								
		A	B	C	8 l/s	13 l/s	21 l/s	29 l/s	37 l/s	45 l/s	53 l/s	61 l/s	
433944	Uninsulated 110 x 54 x 2m	54	110	2000	-	-	-	-	-	-	-	-	-
436599	Uninsulated 110 x 54 x 1.5m	54	110	1500	1.2	2.4	5.3	9.1	13.9	19.8	25.9	32	
496156	Uninsulated 204 x 60 x 1m	60	204	1000	<1	<1	<1	1.5	2.2	3.0	3.9	5.1	
436617	Uninsulated 204 x 60 x 1.5m	60	204	1500	<1	<1	1.3	2.2	3.3	4.5	5.9	7.8	
406870*	Insulated 204 x 60 x 1.5m	160	304	1500	<1	<1	1.3	2.2	3.3	4.5	5.9	7.8	
496160*	204 x 60 x 2m Insulated Sleeve	160	304	2000	-	-	-	-	-	-	-	-	-
496161*	Insulated 204 x 60 x 2m	160	304	2000	-	-	-	-	-	-	-	-	-
474677	Uninsulated 204 x 60 x 2m	60	204	2000	<1	<1	1.7	2.9	4.3	5.9	7.7	10.4	
Stock Ref	Duct Size	A	B	C	60 l/s			120 l/s			180 l/s		
496157	Uninsulated 220 x 90 x 1m	90	220	1000	0.9			3.2			6.7		
407343*	Insulated 220 x 90 x 1.5m	190	320	1500	1.4			4.9			10.2		
403025	Uninsulated 220 x 90 x 1.5m	90	220	1500	1.4			4.9			10.2		
474678	Uninsulated 220 x 90 x 2m	90	220	2000	1.9			2.6			13.6		

Flat Channel Connector. F to F

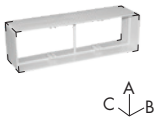

Stock Ref	Duct Size	External Dimensions (mm)			Resistance (Pa) at flow rate								
		A	B	C	8 l/s	13 l/s	21 l/s	29 l/s	37 l/s	45 l/s	53 l/s	61 l/s	
436623**	204 x 60	64	212	100	<1	<1	<1	<1	<1	<1	1.2	1.5	
436605	110 x 54	54	114	100	<1	<1	1.1	1.4	2.2	3.4	4.8	6.4	
Stock Ref	Duct Size	A	B	C	60 l/s			120 l/s			180 l/s		
403026	220 x 90	95	224	52	<1			<1			<1		

Channel Fixing Clip (Pack of 10)

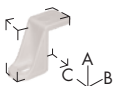

Stock Ref	Duct Size	External Dimensions (mm)			Resistance (Pa) at flow rate					
		A	B	C	60 l/s	120 l/s	180 l/s			
403030	220 x 90	97	44	19	N/A	N/A	N/A			

Horizontal 90° Bend. F to F



Stock Ref	Duct Size	External Dimensions (mm)			Resistance (Pa) at flow rate								
		A	B	C	8 l/s	13 l/s	21 l/s	29 l/s	37 l/s	45 l/s	53 l/s	61 l/s	
406879*	Insulated 204 x 60	160	360	360	0.7	1.7	4.1	8.4	13	18	25	34	
436620**	Uninsulated 204 x 60	65	260	260	0.7	1.7	4.1	8.4	13	18	25	34	
436602	Uninsulated 110 x 54	60	152	152	2.3	9.9	21	38	64	93	124	162	
Stock Ref	Duct Size	A	B	C	60 l/s			120 l/s			180 l/s		
407342*	Insulated 220 x 90	190	350	350	9			36			80		
403028	Uninsulated 220 x 90	95	250	250	9			36			80		

Horizontal 45° Bend. F to F

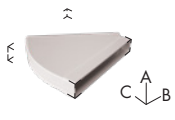

Stock Ref	Duct Size	External Dimensions (mm)			Resistance (Pa) at flow rate								
		A	B	C	8 l/s	13 l/s	21 l/s	29 l/s	37 l/s	45 l/s	53 l/s	61 l/s	
437280	Uninsulated 110 x 54	-	-	-	-	-	-	-	-	-	-	-	
406876*	Insulated 204 x 60	160	340	360	0.2	0.7	1.2	2.1	3.8	6.1	9.2	13	
249944**	Uninsulated 204 x 60	65	240	260	0.2	0.7	1.2	2.1	3.8	6.1	9.2	13	
Stock Ref	Duct Size	A	B	C	60 l/s			120 l/s			180 l/s		
449363	Uninsulated 220 x 90	95	240	200	5			20			46		

* Minimum insulation wall thickness 25mm. Insulation Thermal Conductivity: 0.04 W/(m.K)

** This part comes in Grey. Whilst we will look to maintain the colour of Grey, by the nature of adopting a recycled plastic the colour and shade may vary at any given time.

Horizontal T. F to F to F

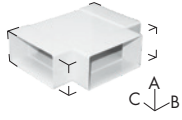

Stock Ref	Duct Size	External Dimensions (mm)			Resistance (Pa) at flow rate							
		A	B	C	8 l/s	13 l/s	21 l/s	29 l/s	37 l/s	45 l/s	53 l/s	61 l/s
406883*	Insulated 204 x 60	160	410	355	vary on installation							
436551**	Uninsulated 204 x 60	65	310	255	vary on installation							
436614	Uninsulated 110 x 54	60	185	150	vary on installation							
Stock Ref	Duct Size	A	B	C	60 l/s			120 l/s			180 l/s	
449365	Uninsulated 220 x 90	95	275	250	vary on installation			vary on installation			vary on installation	

Vertical 90° Bend. F to F

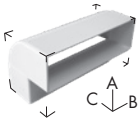

Stock Ref	Duct Size	External Dimensions (mm)			Resistance (Pa) at flow rate							
		A	B	C	8 l/s	13 l/s	21 l/s	29 l/s	37 l/s	45 l/s	53 l/s	61 l/s
406872*	Insulated 204 x 60	215	310	215	1.1	2.5	5.2	9.8	16.1	24	33.6	45
436621**	Uninsulated 204 x 60	115	210	115	1.1	2.5	5.2	9.8	16.1	24	33.6	45
436603	Uninsulated 110 x 54	95	115	95	3.3	15.5	36	61	96	138	190	253
Stock Ref	Duct Size	A	B	C	60 l/s			120 l/s			180 l/s	
403029	Uninsulated 220 x 90	117	224	120	7			28			66	

Vertical 45° Bend. F to F

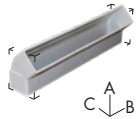

Stock Ref	Duct Size	External Dimensions (mm)			Resistance (Pa) at flow rate							
		A	B	C	8 l/s	13 l/s	21 l/s	29 l/s	37 l/s	45 l/s	53 l/s	61 l/s
406871*	Insulated 204 x 60	200	310	215	0.1	0.5	1.3	2.5	4.4	6.9	10	13.3
445196**	Uninsulated 204 x 60	100	210	115	0.1	0.5	1.3	2.5	4.4	6.9	10	13.3
441655	Uninsulated 110 x 54	115	115	70	1	2.4	6.6	12.9	23.1	35.1	48	64
Stock Ref	Duct Size	A	B	C	60 l/s			120 l/s			180 l/s	
449364	Uninsulated 220 x 90	110	225	115	6			27			65	

Elbow Bend. 100mm to Rectangular. M to F

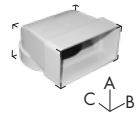

Stock Ref	Duct Size	External Dimensions (mm)			Resistance (Pa) at flow rate							
		A	B	C	8 l/s	13 l/s	21 l/s	29 l/s	37 l/s	45 l/s	53 l/s	61 l/s
436624**	204 x 60	80	215	195	2.9	7.1	15.1	28	45.1	68.1	92.2	118
436607	110 x 54	90	115	140	3	8	17.7	33	49.9	74.5	101	137
Stock Ref	Duct Size	A	B	C	60 l/s			120 l/s			180 l/s	
403027	220 x 90	118	226	240	N/A			N/A			N/A	

Elbow Bend. 125mm to Rectangular. M to F

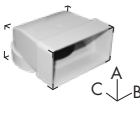

Stock Ref	Duct Size	External Dimensions (mm)			Resistance (Pa) at flow rate							
		A	B	C	8 l/s	13 l/s	21 l/s	29 l/s	37 l/s	45 l/s	53 l/s	61 l/s
436625**	204 x 60	80	215	195	3.1	5.9	12.2	25	43.6	62.2	86	111
Stock Ref	Duct Size	A	B	C	60 l/s			120 l/s			180 l/s	
449361	220 x 90	118	226	240	N/A			N/A			N/A	

*Minimum insulation wall thickness 25mm. Insulation Thermal Conductivity: 0.04 W/(m.K)

**This part comes in Grey. Whilst we will look to maintain the colour of Grey, by the nature of adopting a recycled plastic the colour and shade may vary at any given time.

Ducting & Accessories

Elbow Bend. 150mm to Rectangular. M to F

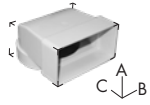

Stock Ref
436626 **

Duct Size
204 x 60

External Dimensions (mm)

A B C

Resistance (Pa) at flow rate

8 l/s 13 l/s 21 l/s 29 l/s 37 l/s 45 l/s 53 l/s 61 l/s
2.8 4.9 11.6 21 31 41 53 67

Stock Ref
449362

Duct Size
220 x 90

A B C

60 l/s
N/A

120 l/s
N/A

180 l/s
N/A

Elbow Bend. 100mm to Rectangular. F to F

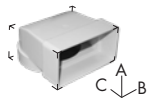

Stock Ref
436608

Duct Size
110 x 54

External Dimensions (mm)

A B C

Resistance (Pa) at flow rate

8 l/s 13 l/s 21 l/s 29 l/s 37 l/s 45 l/s 53 l/s 61 l/s
2.1 5.5 14.3 27.2 44.3 69 93 118

Flat Channel connector with Damper



Stock Ref
400735

Duct Size
110 x 54

External Dimensions (mm)

A B C

Resistance (Pa) at flow rate

8 l/s 13 l/s 21 l/s 29 l/s 37 l/s 45 l/s 53 l/s 61 l/s
16 17.5 19.5 22 25.5 30.5 36 42

Drop down section F to F



Stock Ref
442273 **

Duct Size
204 x 60

External Dimensions (mm)

A B C

Resistance (Pa) at flow rate

8 l/s 13 l/s 21 l/s 29 l/s 37 l/s 45 l/s 53 l/s 61 l/s
0.2 0.5 1.7 3.6 6.0 9.1 12.4 16.6

Single Air Brick Horizontal (System 60 Air Grille Adaptor is supplied with the Single Air Bricks)

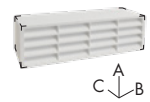

Stock Ref
436612

Duct Size
110 x 54 (Terracotta)

External Dimensions (mm)

A B C

Resistance (Pa) at flow rate

8 l/s 13 l/s 21 l/s 29 l/s 37 l/s 45 l/s 53 l/s 61 l/s
3.2 7.8 20.9 39 65 96 128 176

Stock Ref
436611

Duct Size
110 x 54 (Brown)

A B C

Resistance (Pa) at flow rate

8 l/s 13 l/s 21 l/s 29 l/s 37 l/s 45 l/s 53 l/s 61 l/s
3.2 7.8 20.9 39 65 96 128 176

Single Air Grille Soldier



Stock Ref
438594

Duct Size
204 x 60 (White)

External Dimensions (mm)

A B C

Resistance (Pa) at flow rate

8 l/s 13 l/s 21 l/s 29 l/s 37 l/s 45 l/s 53 l/s 61 l/s
3.3 10 20.6 40 63 92.8 128 168

Stock Ref
468728

Duct Size
204 x 60 (Terracotta)

A B C

Resistance (Pa) at flow rate

8 l/s 13 l/s 21 l/s 29 l/s 37 l/s 45 l/s 53 l/s 61 l/s
3.3 10 20.6 40 63 92.8 128 168

Stock Ref
468730

Duct Size
204 x 60 (Brown)

A B C

Resistance (Pa) at flow rate

8 l/s 13 l/s 21 l/s 29 l/s 37 l/s 45 l/s 53 l/s 61 l/s
3.3 10 20.6 40 63 92.8 128 168

Stock Ref
468729

Duct Size
204 x 60 (Beige)

A B C

Resistance (Pa) at flow rate

8 l/s 13 l/s 21 l/s 29 l/s 37 l/s 45 l/s 53 l/s 61 l/s
3.3 10 20.6 40 63 92.8 128 168

**This part comes in Grey. Whilst we will look to maintain the colour of Grey, by the nature of adopting a recycled plastic the colour and shade may vary at any given time.

Double Air Brick

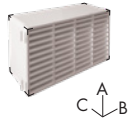

Stock Ref	Duct Size*	Colour	External Dimensions (mm)			Resistance (Pa) at flow rate							
			A	B	C	8 l/s	13 l/s	21 l/s	29 l/s	37 l/s	45 l/s	53 l/s	61 l/s
438604	204 x 60 or 220 x 90	White	145	245	80	0.2	1.6	4.3	8.7	13.9	21.1	27.5	37.4
438607		Terracotta	145	245	80	0.2	1.6	4.3	8.7	13.9	21.1	27.5	37.4
438605		Brown	145	245	80	0.2	1.6	4.3	8.7	13.9	21.1	27.5	37.4
438606		Beige	145	245	80	0.2	1.6	4.3	8.7	13.9	21.1	27.5	37.4

*In conjunction with Double Air Brick Adaptor below

Double Air Brick Adaptor Rectangular Duct

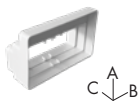

Stock Ref	Duct Size	External Dimensions (mm)			Resistance (Pa) at flow rate								
		A	B	C	8 l/s	13 l/s	21 l/s	29 l/s	37 l/s	45 l/s	53 l/s	61 l/s	
438608	204 x 60	135	226	85	-	-	-	-	-	-	-	-	-
449367	220 x 90	135	226	85	-	-	-	-	-	-	-	-	-

Double Air Brick Adaptor Round Duct

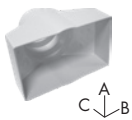

Stock Ref	Duct Size	External Dimensions (mm)			Resistance (Pa) at flow rate								
		A	B	C	8 l/s	13 l/s	21 l/s	29 l/s	37 l/s	45 l/s	53 l/s	61 l/s	
449360	220 x 90 to 100/125/150	-	-	-	-	-	-	-	-	-	-	-	-

Air Grille Adaptor

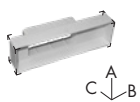

Stock Ref	Duct Size	External Dimensions (mm)			Resistance (Pa) at flow rate							
		A	B	C	8 l/s	13 l/s	21 l/s	29 l/s	37 l/s	45 l/s	53 l/s	61 l/s
436609	110 x 54	65	210	85	0.2	1.2	2.5	4.7	7.8	11	14	18

Flexible Ducting



Stock Ref	Duct Size	External Dimensions (mm)			Resistance (Pa) at flow rate							
		A	B	C	8 l/s	13 l/s	21 l/s	29 l/s	37 l/s	45 l/s	53 l/s	61 l/s
5109662	204 x 60	-	-	-	0.2	0.6	1.5	2.6	4.1	6.0	8.2	11.5
449366	220 x 90	-	-	-	N/A		N/A			N/A		

Louvred Grille with Flyscreen Fitting



Stock Ref	Duct Size	External Dimensions (mm)			Resistance (Pa) at flow rate							
		A	B	C	8 l/s	13 l/s	21 l/s	29 l/s	37 l/s	45 l/s	53 l/s	61 l/s
400743	110 x 54	140	140	50	5.7	14.5	37	75	120	-	-	-

**

Round (M) 100mm to Rectangular (F/M) Adaptor



Stock Ref	Duct Size	External Dimensions (mm)			Resistance (Pa) at flow rate							
		A	B	C	8 l/s	13 l/s	21 l/s	29 l/s	37 l/s	45 l/s	53 l/s	61 l/s
441654**	M to F 204 x 60	140	210	215	1.0	1.96	3.2	4.9	6.7	8.7	11.2	14.5
400740	M to M 110 x 54	100	115	180	1.2	4.2	8.3	19.8	29.9	42	60	86

**This part comes in Grey. Whilst we will look to maintain the colour of Grey, by the nature of adopting a recycled plastic the colour and shade may vary at any given time.

Ducting & Accessories

Round (F) 125mm to Rectangular (F) Adaptor

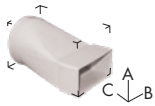

Stock Ref	Duct Size	External Dimensions (mm)			Resistance (Pa) at flow rate							
		A	B	C	8 l/s	13 l/s	21 l/s	29 l/s	37 l/s	45 l/s	53 l/s	61 l/s
370127 **	204 x 60	140	210	213	<1	<1	1.5	2.8	4.5	6.7	9	11.5

Round (F) 150mm to Rectangular (F) Adaptor

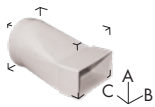

Stock Ref	Duct Size	External Dimensions (mm)			Resistance (Pa) at flow rate		
		A	B	C	60 l/s	120 l/s	180 l/s
403031	220 x 90	160	225	203	N/A	N/A	N/A

Short Round (M) 100mm to 110 x 54 (F) Adaptor



Stock Ref	Duct Size	External Dimensions (mm)			Resistance (Pa) at flow rate							
		A	B	C	8 l/s	13 l/s	21 l/s	29 l/s	37 l/s	45 l/s	53 l/s	61 l/s
455035	110 x 54	60	110	105	1.2	4.3	8.4	20	30.2	43	62	88

Round Ducting Insulated/Uninsulated

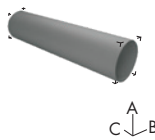

Stock Ref	Duct Size	External Dimensions (mm)			Resistance (Pa) at flow rate							
		A	B	C	8 l/s	13 l/s	21 l/s	29 l/s	37 l/s	45 l/s	53 l/s	61 l/s
497488	Uninsulated 100 Ø x 1m	100	100	1000	<0.5	<0.5	0.85	1.4	1.8	2.25	2.65	3.1
406873	Insulated 100 Ø* x 2m	200	200	2000	<1	<1	1.7	2.8	3.6	4.5	5.3	6.2
5108250	Uninsulated 100 Ø x 2m	100	100	2000	<1	<1	1.7	2.8	3.6	4.5	5.3	6.2
496155	Uninsulated 120 Ø x 1m	120	120	1000	<0.5	<0.5	<0.5	0.65	0.9	1.2	1.55	1.9
434715	Uninsulated 125 Ø* x 1.5m	125	125	1500	<1	<1	<1	1.3	1.8	2.4	3.1	3.8
406874	Insulated 125 Ø* x 2m	225	225	2000	<1	<1	<1	1.3	1.8	2.4	3.1	3.8
496158	Uninsulated 150 Ø x 1m	150	150	1000	<0.5	<0.5	<0.5	<0.5	0.6	0.8	1	1.25
496159	Uninsulated 150 Ø x 1.5m	150	150	1500	-	-	-	-	-	-	-	-
406875	Insulated 150 Ø* x 2m	265	265	2000	<1	<1	<1	<1	1.2	1.6	2	2.5
5108248	Uninsulated 150 Ø x 2m	150	150	2000	<1	<1	<1	<	1.2	1.6	2	2.5

Equal Tee Insulated/Uninsulated MMM

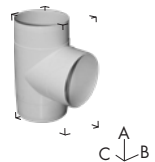

Stock Ref	Duct Size	External Dimensions (mm)			Resistance (Pa) at flow rate							
		A	B	C	8 l/s	13 l/s	21 l/s	29 l/s	37 l/s	45 l/s	53 l/s	61 l/s
406884	Insulated 100 Ø*	290	210	235	vary on installation							
372007	Uninsulated 100 Ø	190	110	135	vary on installation							
406885	Insulated 125 Ø*	310	215	260	vary on installation							
428636	Uninsulated 125 Ø	210	115	160	vary on installation							
406886	Insulated 150 Ø*	335	245	285	vary on installation							
370237	Uninsulated 150 Ø	235	130	177	vary on installation							

* Minimum insulation wall thickness 25mm. Insulation Thermal Conductivity: 0.04 W/(m.K)

** This part comes in Grey. Whilst we will look to maintain the colour of Grey, by the nature of adopting a recycled plastic the colour and shade may vary at any given time.

90° Bend Insulated/Uninsulated MM



Stock Ref	Duct Size	External Dimensions (mm)			Resistance (Pa) at flow rate								
		A	B	C	8 l/s	13 l/s	21 l/s	29 l/s	37 l/s	45 l/s	53 l/s	61 l/s	
406880	Insulated 100 Ø*	230	200	200	2.8	5.5	11	20.3	33	45	60	79	
372004	Uninsulated 100 Ø	130	100	100	2.8	5.5	11	20.3	33	45	60	79	
406881	Insulated 125 Ø*	260	230	230	<1	1.8	5	8.2	11.8	18	26	35	
427360	Uninsulated 125 Ø	160	130	130	<1	1.8	5	8.2	11.8	18	26	35	
406882	Insulated 150 Ø*	290	255	255	<1	1.0	2.5	4.1	6.4	9.6	13.5	18	
370295	Uninsulated 150 Ø	190	155	155	<1	1.0	2.5	4.1	6.4	9.6	13.5	18	

45° Bend Insulated/Uninsulated MM



Stock Ref	Duct Size	External Dimensions (mm)			Resistance (Pa) at flow rate								
		A	B	C	8 l/s	13 l/s	21 l/s	29 l/s	37 l/s	45 l/s	53 l/s	61 l/s	
406877	Insulated 100 Ø*	280	200	230	<1	1.9	8.1	11.7	17.5	24.6	31.4	-	
372005	Uninsulated 100 Ø	180	100	130	<1	1.9	8.1	11.7	17.5	24.6	31.4	-	
406878	Insulated 125 Ø*	300	230	250	<1	<1	1.8	2.9	4.6	6.6	9	12.2	
441657	Uninsulated 125 Ø	200	130	150	<1	<1	1.8	2.9	4.6	6.6	9	12.2	

Connector MM

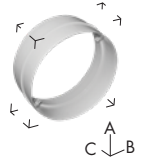

Stock Ref	Duct Size	External Dimensions (mm)			Resistance (Pa) at flow rate								
		A	B	C	8 l/s	13 l/s	21 l/s	29 l/s	37 l/s	45 l/s	53 l/s	61 l/s	
372006	100 Ø	100	60	-	-	-	-	-	-	-	-	-	
428633	125 Ø	125	60	-	-	-	-	-	-	-	-	-	
370299	150 Ø	150	60	-	-	-	-	-	-	-	-	-	

Reducer



Stock Ref	Duct Size	External Dimensions (mm)			Resistance (Pa) at flow rate								
		A	B	C	8 l/s	13 l/s	21 l/s	29 l/s	37 l/s	45 l/s	53 l/s	61 l/s	
VA54119	125 to 100	130	57	-	-	-	-	-	-	-	-	-	
428632	150 to 125	155	57	-	-	-	-	-	-	-	-	-	

Equal Y Piece

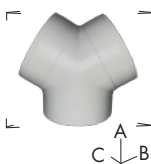

Stock Ref	Duct Size	External Dimensions (mm)			Resistance (Pa) at flow rate								
		A	B	C	8 l/s	13 l/s	21 l/s	29 l/s	37 l/s	45 l/s	53 l/s	61 l/s	
497426	100mm/4"	150	175	100	-	-	-	-	-	-	-	-	
497428	125mm/5"	173	199	125	-	-	-	-	-	-	-	-	
497430	150mm/6"	195	225	150	-	-	-	-	-	-	-	-	

* Minimum insulation wall thickness 25mm. Insulation Thermal Conductivity: 0.04 W/(m.K)

** This part comes in Grey. Whilst we will look to maintain the colour of Grey, by the nature of adopting a recycled plastic the colour and shade may vary at any given time.

Ducting & Accessories



Fabric Woven PVC Flexible Ducting

Manufactured using fabric woven PVC with a wire helix. Used with single spigots and in multi-duct systems. Operating temperature -30°C to 70°C.

6 metre lengths

Duct Size	Stock Ref
100 Ø	427569
125 Ø	427570
150 Ø	370281

T-Series Flexible Ducting

PVC with wire helix. For use with T-Series.

6m lengths

Size	Duct Size	Stock Ref
Size 6	175 Ø	566607
Size 7	225 Ø	566609
Size 9	300 Ø	566612
Size 12	400 Ø	566616



Insulated Flexible Ducting

Insulated ducting should be used when duct passes through an unheated area. Minimises heat loss when used with heat recovery fans. Available in 6 diameters. An additional benefit is that thermally insulated duct offers some measure of acoustic attenuation.

10 metre lengths

Duct Dia	Stock Ref
100 Ø	561654
125 Ø	561655
150 Ø	561656



Duct Y Piece

For dividing a ventilation system, providing ducting to multiple supply or extract grilles using only a single fan source.

2x Into	1x	Stock Ref
100 Ø	100 Ø	452081
100 Ø	150 Ø	452082
125 Ø	125 Ø	455211
125 Ø	150 Ø	455212
150 Ø	150 Ø	452083
150 Ø	200 Ø	452084
200 Ø	200 Ø	452085
200 Ø	250 Ø	452078
250 Ø	250 Ø	452076
250 Ø	300 Ø	452079



Acoustic Insulated Ducting

Multiple layer aluminium/polyester laminate with micro perforated flexible core to enhance acoustic performance. Core surrounded by 25mm fibreglass insulation with outer vapour barrier.

Duct Size	Length	Stock Ref
100 Ø	1m	443273
125 Ø	1.5m	443793
150 Ø	1m	443274



Reducer

Duct Size	Stock Ref
R125/100	370302
R150/100	370303
R150/125	370304
R200/150	370307
R250/200	370309
R300/100	370310
R300/200	370312



Circular Extract Diffuser

Manufactured from powder coated steel. Suitable for exhausting air and can be fitted directly to the duct or in the ceiling.

Duct Size	Stock Ref
125 Ø	10544125



Circular Supply Diffuser

Manufactured from powder coated steel. Suitable for supplying air and can be fitted directly to the duct or in the ceiling.

Duct Size	Stock Ref
100 Ø	10543100



Acoustic Mat

486mm x 486mm x 25mm thick foam mat for use as a resilient mounting for wholehouse units.

Model	Stock Ref
ACM/House	370179



Circular Push-Fit Supply Diffuser

Manufactured from ABS. Easy to install by direct push-fit into duct. Suitable for supplying air and can be fitted directly to the duct or in the ceiling.

Duct Size	Stock Ref
100 Ø	476936
125 Ø	476937
150 Ø	476938
200 Ø	476939



Circular Push-Fit Extract Diffuser

Manufactured from ABS. Easy to install by direct push-fit into duct. Suitable for supplying air and can be fitted directly to the duct or in the ceiling.

Duct Size	Stock Ref
100 Ø	476944
125 Ø	476945
150 Ø	476946
200 Ø	476947

Galvanised Spiral Wound Ducting

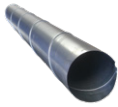

Spiral Ductwork - 3m Length

Duct Size	Stock Ref
100 Ø	400900
125 Ø	400901
150 Ø	400902
200 Ø	410922
250 Ø	410923
315 Ø	410924



Joining Piece

In sheet metal. For joining lengths of flexible ducting to give long lasting airtight connection.

Duct Size	Stock Ref
100 Ø	561804
125 Ø	561805
150 Ø	561806
200 Ø	561808
250 Ø	561810
315 Ø	561813



Equal Tee

Duct Size	Stock Ref
100 Ø	400749
125 Ø	400750
150 Ø	400751
200 Ø	370238
250 Ø	370239
315 Ø	410925



Rectangular Balancing Damper

Duct Size	Stock Ref
110 x 54	405156
204 x 60	403698
220 x 90	403699



90° Bend

Duct Size	Stock Ref
100 Ø	400752
125 Ø	400753
150 Ø	400754
200 Ø	370202
250 Ø	370203
315 Ø	410926



Circular Balancing Damper

Duct Size	Stock Ref
100 Ø	400758
125 Ø	400759
150 Ø	400760
200 Ø	410930
250 Ø	410931
315 Ø	410932



Female Coupler

Duct Size	Stock Ref
100 Ø	400755
125 Ø	400756
150 Ø	400757
200 Ø	410927
315 Ø	410929

Fire Stopping

Vent-Axia provides a complete range of fire stopping products specifically tested with ventilation ducting. This versatile selection allows for stacking and parallel installation in certain circumstances, along with creative solutions for partition walls and slab mounting. All Fire Sleeves provide 120 minutes Integrity & Insulation. Fire Rated diffusers are tested successfully to 60 minutes.

Please note: For installations above 18m for England / Wales and NI and 11m for Scotland, all external grilles/parts used within the system must comply with BSEN13501-1:2018.



Fire Rated Diffuser

Duct Size	Extract Stock Ref	Supply Stock Ref
100 Ø	403431	475661
125 Ø	403432	475662
150 Ø	403433	475663
200 Ø	408828	475664

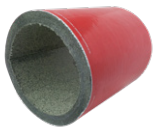

Round Fire Sleeve - Low profile

Thickness:	10-15mm
Length:	280mm (180mm)
CE Marked	407655
Duct Size	Stock Ref
100mm	407655
125mm	407656
150mm	407657



Rectangular Fire sleeve - Low profile - 4 sided

Thickness:	10-15mm
Length:	180mm
CE Marked	
Duct Size	Stock Ref
110x54mm	407658
204x60mm	407659
220x90mm	407660



Ceiling Fan Fire Stop

For ceiling breaks only

Model

100mmØ Fire Collar - 30 min fire-rated
125mmØ Fire Collar - 30 min fire-rated

Stock Ref

435134
435135

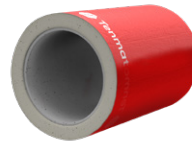

Round Fire Sleeve

Model

Round 100mm sleeve
Round 125mm sleeve
Round 150mm sleeve

Stock Ref

403428
403429
403430

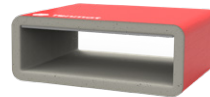

Rectangular Fire sleeve

Model

Rectangular 204x60mm sleeve - 3 sided
Rectangular 204x60mm wrap

Stock Ref

403498
435138

Fire Sleeves are tested & approved to:

BS EN 1366-3: 2009 - Uncapped/Uncapped (U/U) Constructions = Plasterboard & Masonry Walls

Fire Rating: EI120 (120 mins Integrity & Insulation)

Report No.'s: RF13219A, RF12096, RF10167, IF11007, IF10066, IF05055, IF06016, / Chiltern Int. Fire PAR/11078/01-IFC Assessment Report

Fire Rated Diffusers successfully tested for 60 minutes according to BS EN 1365-2:1999 Test Report Number: BTC 18074F & CHILT/IF10090

Fire Test Assessment also covers multiple flat ducts to be installed in series / side by side, max. 3No., 30, 60 & 120 Minute Partitions, Single & Double Boards.

Note: For a copy of the Fire Certificates for the product(s) above, visit our webpage www.vent-axia.com/range/ventilation-fire-stopping.

100 - 150mm Accessories



Wall Fitting Kit

A range of wall kits suitable for Vent-Axia range of 100 - 150mm fans. The kit can be installed into most walls using the telescopic liners supplied.

White

Model	Stock Ref
100mm	254102
125mm	455226
150mm	140902

Brown

Model	Stock Ref
100mm	254100
125mm	497434
150mm	140903

Terracotta

Model	Stock Ref
125mm	497432



Window Fitting Kit

For use in single or sealed double glazing and most materials up to 40mm thick.

White

Model	Stock Ref
VA100 (105Ø)	254101
VA100 (110Ø)	443234
Centra/Sil 100	442947
VA140/150	140901
Solo Pro	11461685



Air Grille

Louvre grille for external termination of 100mm diameter rigid ducting. Consists of wall mounting piece and grille with 2 fixing screws.

Colour:	White or Brown
Dimensions:	155 x 155 x 32mm
Material:	ABS plastic

Colour	Stock Ref
White	563511
Brown	563500



Termination Set

Used as a decorative inlet grille or soffit termination set in conjunction with 100mm or 125mm diameter ducting. Two fixing screws supplied to secure grille to the spigot through material up to 25mm thick. Dimension 155mm x 155mm.

Colour:	White
Material:	ABS plastic

Stock Ref	563513
-----------	--------



Decoration Frame

A decoration frame that converts old Centrif to new Centrif Duo without the need to redecorate. The frame can be used with Quadra and Centrif Duo Plus.

The frame is simply installed using two wall fixing screws, allowing the fan to be mounted via its standard mountings. Finished in a high moulded material plastic colour matched to the fan.

Colour: White
 Size: 386mm x 296 x 32 mm deep

Stock Ref
442551



Quick Fit 100mm Airflow Shutter

Shutter with gravity flaps to protect against backdraught. The spigot connects to 100mm rigid ducting using quick fix grips provided.

Dimensions: 155 x 155 x 20mm
 Material: Plastic

Colour Stock Ref
 White **563522**
 Brown **563542**



External Terminations Louvre Grille with Spigot

Plastic louvre grilles with either 100mm, 125mm or 150mm diameter spigots.

Duct Size	Colour	Stock Ref
100 Ø	Terracotta	370328
100 Ø	Brown	370329
100 Ø	White	370330
100 Ø	Grey	495334
100 Ø	Cotswold Stone	495335
100 Ø	Black	495336
125 Ø	Terracotta	403569
125 Ø	Brown	436649
125 Ø	White	372278
125 Ø	Grey	403568
125 Ø	Cotswold Stone	403570
125 Ø	Black	495337
150 Ø	Brown	370337
150 Ø	Terracotta	370338
150 Ø	White	370339
150 Ø	Grey	495338
150 Ø	Cotswold Stone	495339
150 Ø	Black	495340

100 - 150mm Accessories



Quick Fit 100mm Grille

Terminates a rigid duct on an outside wall using the 'quick fix' side grips without the need for additional fixings.

Colour	Stock Ref
White	563521
Brown	563541



Vent Cowl

External termination for 110mm diameter rigid ducting through roofs and walls in exposed situations. Overall diameter 200mm. Not suitable for use with flexible ducting.

Material	Stock Ref
Grey PVCu	561403
White	457845



Quick Fix Termination

The quick fix termination is designed to be installed from inside the building to a nominal 117mm or 165mm diameter core-cut hole, saving time and cost. Four sealing rings ensures a weather tight fit to the wall external leaf. Effective length 370mm.

Duct Size	Stock Ref
100 Ø	563535
150 Ø	434656



Air Replacement Set

Bathroom and toilet ventilation is only effective when there is adequate air replacement into the room. This is often most effectively achieved by fitting a pair of air replacement grilles at low level in a door. Consists of a two piece telescopic set which fits unobtrusively on either side of the door panel.

Minimum fixing thickness:	30mm
Dimensions:	454 x 90mm
Hole size:	435 x 76mm
Material:	HIPS / High Impact Polystyrene
Free area:	16,600mm ²

Colour	Stock Ref
Ivory	561401



Condensation Trap

Condensation trap, for fitting in vertical rigid PVCu pipe ducting. Must be used where pipe ducts pass through unheated roof voids. Fitted with 20mm pipe connection for running off condensate. Not suitable for use with flexible ducting.

Length:	85mm
Material:	Grey PVCu

Size	Stock Ref
100mm	563516A
125mm	455191

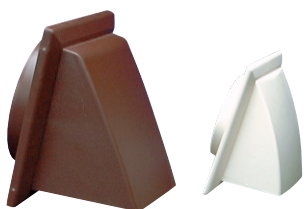

Wind Baffles

A range of 150mm wind baffles. Cowled wall outlet with damper protected gravity grille including foam lined damper to reduce noise.

Available in white and brown they are ideal for exposed coastal applications, helping to prevent unwanted backdraughts.

150mm

Colour

White

Brown

Stock Ref

452096

452097



VA140/150 Window Wind Cowl

Wind cowl for exposed areas.

Stock Ref

455262



Wind Baffle Kits

100mm wind baffle kit consisting of a telescopic wall tube and wind baffle. Available with either a white or brown wind baffle including foam lined damper to reduce noise.

Colour

White

Brown

Stock Ref

407382

407577

















Commercial Range



Lo-Carbon T-Series

The UK's No. 1 Commercial Fan is available with a low energy DC motor providing up to 65% energy saving. The motor is designed to provide longer life, improved performance, lower running costs and maintain the T-Series rugged reliability. Vent-Axia have improved the way this product can be purchased for the refurbishment market. As well as being able to purchase it as you always have, you can also purchase it as a fan core plus optional application specific fitting kit, which gives you more flexibility in both stocking and installing the product. It also supports our lo-carbon drive to reduce waste and landfill.

Vent-Axia[®]

	ACM 100-200	H:3-H:4
	ACM 250-315	H:5-H:6
	Powerflow Range	H:7-H:8
	Lo-Carbon T-Series Overview	H:9-H:10
	Lo-Carbon T-Series Window Fan	H:11-H:12
	Lo-Carbon T-Series Wall Fan	H:13-H:14
	Lo-Carbon T-Series Roof Fan	H:15-H:16
	Lo-Carbon T-Series Panel Fan	H:17-H:18
	Traditional T-Series Overview	H:19-H:20
	Traditional T-Series Window Fan	H:21-H:22
	Traditional T-Series Wall Fan	H:23-H:24
	Traditional T-Series Roof Fan	H:25-H:26
	Traditional T-Series Panel/Ceiling Fan	H:27-H:28
	Traditional T-Series Darkroom Fan	H:29-H:30
	Traditional T-Series In-line Fan	H:31-H:32
	Super T-Series Heavy Duty Wall Fans	H:33-H:34
	Traditional Standard Range Spares	H:35-H:38

ACM 100-200

- Designed and manufactured in the UK
- Three speed motor
- Timer versions available
- Removable motor core
- Rotating motor chassis
- IP44 rated
- Aesthetically pleasing with wipe clean polymer casing
- Sound data from independent testing
- Running speed selected on installation



Ducted Ventilation

Vent-Axia has designed a complete range of energy efficient Mixed Flow In-Line fans that are now quieter, offer two and half times the pressure of conventional axial fans and are dimensionally more compact making them ideal for many ducted applications.

The ACM Mixed Flow In-Line fan can operate in both horizontal and vertical positions.

Motor

All motors have three speeds selectable on installation and are fitted with Standard Thermal Overload Protection (S.T.O.P.). Designed for ambient temperatures up to +50°C. All sizes with capacitor run motors. All sizes are Class II appliances. Supply voltage 220-240V/1/50Hz.

Installation

These units have a separate footplate for simple location mounting and detachable spigots for simple connection to ducting. The motor body chassis rotates to provide connection in acute spaces. Cleaning the product is simple as all parts can be removed without removing the ducting.

Controller

For optimum variable speed performance use a Vent-Axia 1.5 Amp electronic controller. Surface mounted providing variable speed control with an On/Off/sensor slider with indication light. There is an adjustable minimum speed setting. The controller has electrical connections for use with suitable external sensors. Cannot be used with timer models.

1.5 Amp Controller (Suitable for 100mm - 200mm models). Dimensions: 86 x 156 x 53mm (H x W x D).

Stock Ref

W300310

For flush fitting, a metal wall box accessory is available.

Stock Ref

400144

Hole for wall box: 80 x 150 x 150mm (H x W x D).

H:3

Models

Model	Stock Ref
ACM100	17104010
ACM100T	17104020
ACM125	17105010
ACM125T	17105020
ACM150	17106010
ACM150T	17106020
ACM200	17108010
ACM200T	17108020

Dimensions (mm)

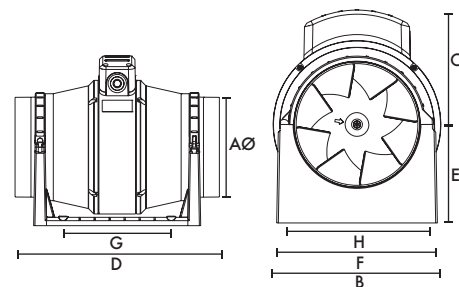

Size	100	125	150	200
AØ	97	122	147	199.5
B	178	178	200	223
C	124	124	138	146
D	298	259	350	300
E	96	96	118	130
F	168	168	192	195
G (fixing hole)	120	120	162	100
H (fixing hole)	153.5	153.5	178	180

Performance Guide

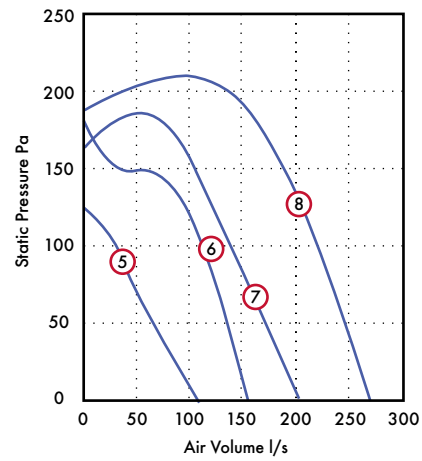
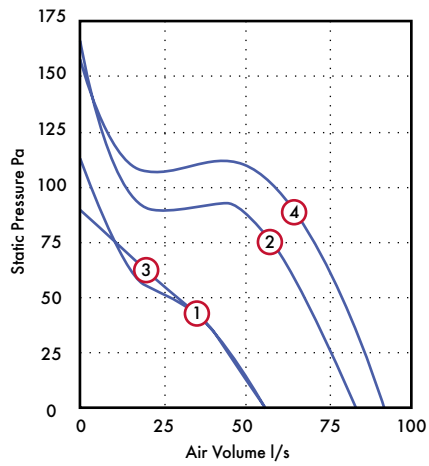

Dia.	Motor Phase	Speed	r.p.m	IP Rating	Curve Ref.	0	50	100	150	200	Motor kW	F.L.C Amps	dB(A) @ 3m
100	1	Low	1580	IP44	1	55	28	-	-	-	0.02	0.09	16
100	1	High	2200	IP44	2	85	69	33	-	-	0.02	0.1	22
125	1	Low	1450	IP44	3	55	30	-	-	-	0.02	0.1	17
125	1	High	2400	IP44	4	92	79	60	-	-	0.03	0.12	24
150	1	Low	1645	IP44	5	105	65	31	-	-	0.04	0.17	29
150	1	High	2350	IP44	6	155	135	112	46	-	0.05	0.21	36
200	1	Low	1845	IP44	7	204	170	138	103	-	0.08	0.48	26
200	1	High	2350	IP44	8	270	247	220	188	134	0.11	0.55	41

*Medium speed is not shown.

Sound Data

Dia.	Spectrum	63	125	250	500	1k	2k	4k	8k	dB(A) @ 3m
100	Breakout High	32	36	41	39	37	37	28	22	22
100	Breakout Low	30	31	34	36	28	29	23	22	16
100	Inlet High	38	42	57	56	54	46	38	30	37
100	Inlet Low	35	40	49	49	47	37	28	24	30
100	Outlet High	36	41	52	52	53	44	37	28	34
100	Outlet Low	38	41	45	46	45	36	28	24	27
125	Breakout High	32	33	38	41	41	40	33	23	24
125	Breakout Low	27	33	30	39	30	29	24	22	17
125	Inlet High	36	47	53	58	55	53	47	39	39
125	Inlet Low	38	42	45	48	45	41	35	26	29
125	Outlet High	36	47	51	54	55	50	46	37	37
125	Outlet Low	33	41	45	45	44	38	33	25	26
150	Breakout High	26	28	41	45	48	54	41	29	36
150	Breakout Low	21	29	45	49	43	44	32	22	29
150	Inlet High	40	49	59	63	59	63	55	47	46
150	Inlet Low	38	46	52	57	52	54	46	37	38
150	Outlet High	36	48	54	60	58	61	54	46	44
150	Outlet Low	33	45	49	54	54	52	45	36	37
200	Breakout High	38	53	47	47	56	60	44	33	41
200	Breakout Low	26	46	40	34	30	26	18	21	26
200	Inlet High	46	52	54	60	61	63	60	49	47
200	Inlet Low	38	37	40	41	39	35	24	23	22
200	Outlet High	63	68	69	73	70	69	62	54	54
200	Outlet Low	53	54	52	52	48	47	39	28	33

ACM 250-315

- Available in two sizes
- Supplied complete for simple installation
- Optimise fan performance by using an approved Vent-Axia controller
- Diagonal impeller with stator
- Galvanized metal housing
- Integrated thermal switch
- Includes a mounting bracket
- Designed to meet IP54



Ducted Ventilation

Vent-Axia has designed a complete range of energy efficient Mixed Flow In-Line fans for use with rigid and flexible ducting.

In-line Mixed Flow fans offer two and half times the pressure of conventional axial fans and are dimensionally more compact making them ideal for many ducted applications.

The ACM Mixed Flow In-Line fan can operate in both horizontal and vertical positions and can be mounted to meet its optimum performance.

Motor

All motors are fitted with Standard Thermal Overload Protection (S.T.O.P.). Designed for ambient temperatures up to +50°C. All sizes with capacitor run motors. ACM 250 and 315 are Class I appliances. Supply voltage 220-240V/1/50Hz.

Models

Model	Stock Ref
ACM250	17110010
ACM315	17112010

ACM 250 Controller

For optimum performance use a Vent-Axia electronic controller. Surface mounted providing variable speed control with an On/Off/sensor slider with indication light. There is an adjustable minimum speed setting. The controller is radio suppressed to BS EN 55014 and electrical connections for use with suitable external sensors are provided.

1.5 Amp Controller - Suitable for 250mm model

Dimensions: 86 x 156 x 53mm (H x W x D).

Model	Stock Ref
1.5A Electronic Controller	W300310

ACM315 Controller

The electronic infinitely variable fan speed controller allow you to manually adjust the speed of single phase AC fans by varying the motor voltage through phase angle control. The integrated switch enables or disables the motor.

Supply voltage:	230 VAC / 50–60 Hz
Regulated output:	U _{min} –U _s
Min. speed adjustment:	80–180 VAC
Unregulated output:	230VAC max 2.0A
Protection standard - Flush mounting:	IP44*
Protection standard - Surface mounting:	IP54*
Ambient conditions - Temperature:	0–40 °C
Ambient conditions - Rel. humidity:	5–95 % rH (non-condensing)
Maximum load - Rated max. current:	0.2 - 3.0A

*According to EN 60529

Model	Stock Ref
3A Transformer Controller	SC5030

Dimensions (mm)

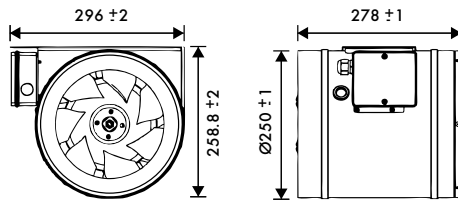

ACM250

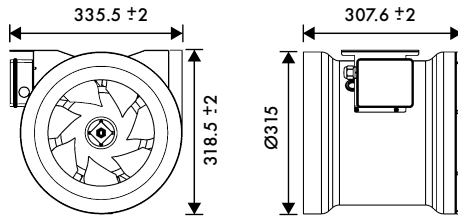

ACM315

Performance Guide

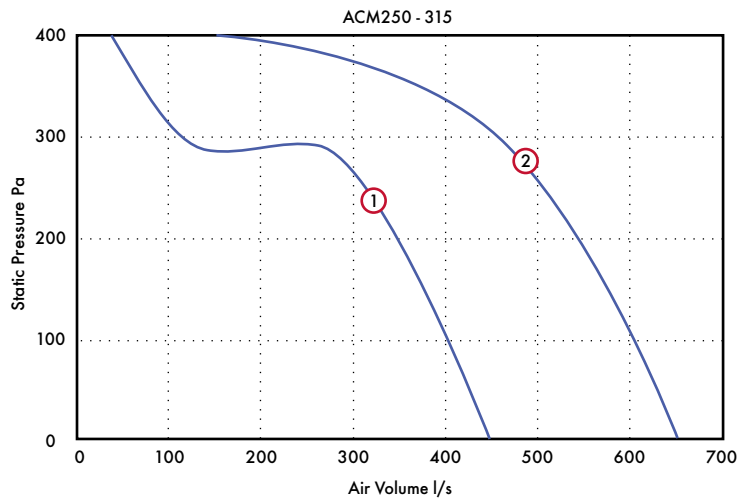

Dia.	Stock Ref.	Poles	r.p.m	IP Rating	Curve Ref.	l/s @ Pa					Motor kW	S.C. Amps	F.L.C Amps	dB(A) @ 3m
						0	100	200	300	400				
250	17110010	2	2720	IP54	1	450	410	350	120	40	0.14	0.8	1	53
315	17112010	2	2840	IP54	2	650	610	540	460	150	0.27	1.2	1.6	56

Sound Data

Dia.	Spectrum	dB(A) @ 3m							
		125	250	500	1k	2k	4k	8k	
250	Inlet	34	54	61	65	67	66	55	72
250	Outlet	39	64	68	71	70	66	55	78
250	Breakout	34	41	43	46	46	42	37	54
315	Inlet	45	60	66	68	69	67	56	75
315	Outlet	47	69	73	74	72	66	57	79
315	Breakout	38	41	46	50	49	46	41	58

Powerflow (ACP)

- Tough plastic in-line range in seven models
- 50-80mm long ribbed spigots
- Flame retardant casing
- All models speed controllable
- Fitted with Standard Thermal Overload Protection (S.T.O.P.)
- For the best performance from your fan, use a Vent-Axia controller
- IP44 Rated



Ducted Ventilation

Powerflow models provide a compact yet versatile range designed with the installer in mind, combining the acoustic benefits of a tough plastic casing with the pressure characteristics of a centrifugal fan.

A range of seven models available from 100 to 315mm dia. duct sizes. The 315mm dia. model has been specifically developed for use with rigid ductwork. Air volumes from 59l/s to 340l/s in free air and capable of pressure development up to 500 Pa.

Powerflow has 50-80mm long inlet and discharge spigots allowing easy installation and fixing. The adjustable mounting foot allows the terminal box to be rotated to any angle and allows plenty of space and adjustment for screw fixing. The robust fire retardant polymeric casing combined with internal guide vanes ensures optimum airflow management through the unit.

Electrical

Motors are 220-240V single phase 50Hz. Capacitor start and run. The terminal box is integral with the case moulding. All motors are fitted with Standard Thermal Overload Protection (S.T.O.P.).

Motor/Impeller

All models are fitted with an external rotor motor and backward curved impeller assembly for long life and reliability.

All sizes are IP44 according to BS EN 60529. Ball bearings are greased for life and designed to run at any angle. Insulation is Class 'B' (from -30°C to +40°C). Manufacture is controlled to BS EN ISO 9001.

Models

2 Pole In-Line Duct Fan - Single Phase.

Stock Ref

ACP10012

ACP12512

ACP15012

ACP16012

ACP20012

ACP25012

ACP31512

2.5A Electronic Controller

On/Off indication light. Infinitely variable speed control. Adjustable minimum speed setting and optional sensor mode. The controller is radio-suppressed to BS800 and rated at 2.5 amps.

Model

Stock Ref

2.5A Electronic Controller **W10303102M**

Dimensions (mm)

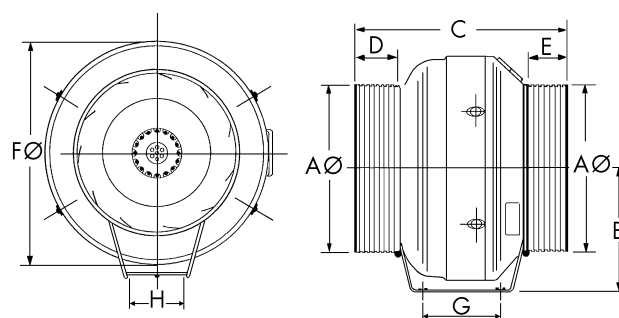

Dia	AØ	B	C	D	E	FØ	G	H	Weight
100	100	146	287	52	52	254	110	270*	2.2
125	125	146	287	60	60	254	110	270*	2.2
150	149	175	287	52	52	301	110	270*	3.1
160	160	175	287	52	52	301	110	270*	3.1
200	200	193	290	47	47	344	92	130	4.3
250	250	218	312	65	65	367	92	130	4.6
315	315	250	366	76	76	405	92	130	5.9

*Sizes 100, 125, 150 & 160 have a flat mounting foot

Performance Guide

100 to 315 dia. - 1 Phase - 2 Pole

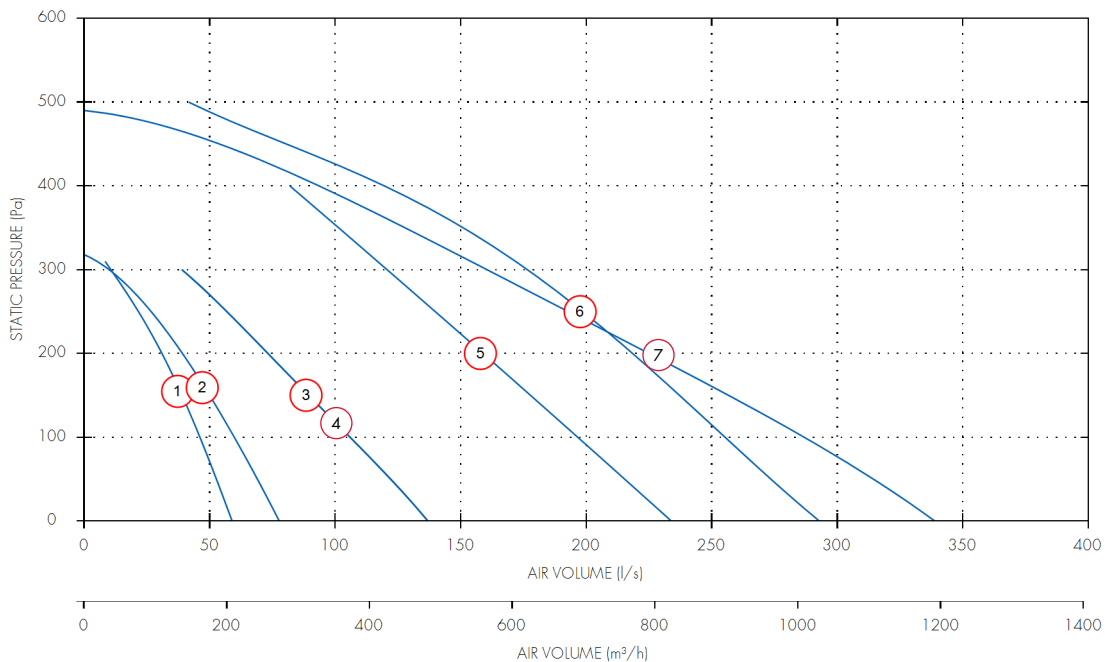

Dia.	Motor Phase	Stock Ref	r.p.m	IP Rating	Curve Ref.	l/s at Pa					Motor kW	S.C. Amps	F.L.C Amps	dB(A) @ 3m
						0	100	200	300	400				
100	1	ACP10012	2740	IP44	1	60	50	30	10		0.08	0.85	0.34	35
125	1	ACP12512	2410	IP44	2	80	60	40	10		0.08	0.85	0.34	35
150	1	ACP15012	2520	IP44	3	140	110	70	40		0.1	1.1	0.43	45
150	1	ACP16012	2520	IP44	4	140	110	70	40		0.1	1.1	0.43	45
200	1	ACP20012	2620	IP44	5	230	200	160	120		0.15	1.52	0.68	47
250	1	ACP25012	2720	IP44	6	290	260	220	180	120	0.19	1.6	0.77	48
315	1	ACP31512	2720	IP44	7	340	290	220	160	90	0.18	1.57	0.75	51

Sound Data

Dia.	Motor Phase	Stock Ref.	Spectrum	dB(A) @ 3m								
				63	125	250	500	1k	2k	4k	8k	
100	1	ACP10012	Inlet	81	84	75	68	61	52	46	40	51
100	1	ACP10012	Outlet	82	84	77	68	61	52	49	43	52
100	1	ACP10012	Breakout	52	48	57	53	53	48	40	38	36
125	1	ACP12512	Inlet	80	79	76	70	61	57	51	45	51
125	1	ACP12512	Outlet	82	80	76	71	61	54	51	43	52
125	1	ACP12512	Breakout	52	48	57	53	53	48	40	38	36
150	1	ACP15012	Inlet	79	84	84	76	69	65	61	52	58
150	1	ACP15012	Outlet	78	84	83	74	69	65	60	50	57
150	1	ACP15012	Breakout	59	62	66	62	62	58	51	43	45
150	1	ACP16012	Inlet	81	81	79	76	66	61	58	49	55
150	1	ACP16012	Outlet	80	82	81	73	67	62	57	49	55
150	1	ACP16012	Breakout	59	62	66	62	62	58	51	43	45
200	1	ACP20012	Inlet	80	79	74	76	67	65	66	60	55
200	1	ACP20012	Outlet	79	79	74	71	69	69	65	59	55
200	1	ACP20012	Breakout	54	70	67	66	62	59	53	43	47
250	1	ACP25012	Inlet	84	80	74	74	69	69	67	63	56
250	1	ACP25012	Outlet	75	79	73	72	72	73	68	64	58
250	1	ACP25012	Breakout	60	71	70	66	65	62	55	44	49
315	1	ACP31512	Inlet	84	80	74	74	69	69	67	63	56
315	1	ACP31512	Outlet	75	79	73	72	72	73	68	64	58
315	1	ACP31512	Breakout	72	71	73	71	66	63	55	45	52

Lo-Carbon T-Series Range Overview

- Wall, Window, Roof and panel mounting versions available
- Low Energy DC Motor
- Up to 70% energy saving
- Modular design, available as a complete unit or as a separate fitting kit and fan core for refurbishment



ErP Regulations

The introduction of the ErP regulations gave us the opportunity to review our product ranges and has enabled us to improve the way we stock and sell them. You can still buy the market leading T-Series in the same way you always have, as a complete product, however we have taken the opportunity to add a more flexible option if you need it. We have introduced a modular option for refurbishment situations where you may not want to replace the whole product.

For new build projects and complete building refits the market leading T-Series is unchanged and available as a complete unit generally supplied in one carton.

For refurbishment markets, supplying it as separate core and specific fitting kit gives more flexibility in both stocking and installing the product. This also gives the lowest overall cost to refurbish your fan system without changing wiring or controls, furthermore it also supports our Lo-Carbon drive to reduce waste and landfill.

Wired controller available to make the Lo-Carbon T Series range the most flexible, efficient and controllable range of commercial wall and window fan systems.

Complete Product Option

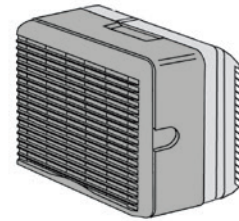

Complete product

Modular Option

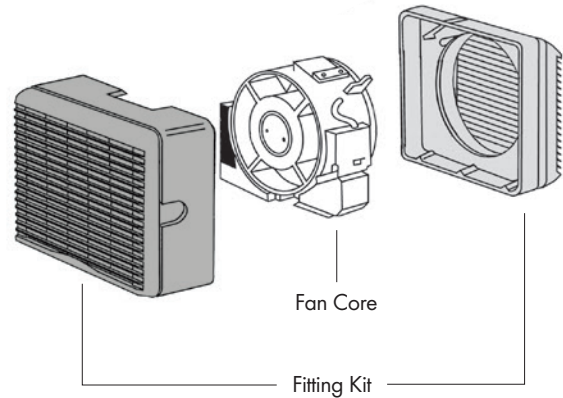

Lo-Carbon T-Series Complete Fan



Controller Type*	Size	Window Stock Ref	Wall Stock Ref	Roof Stock Ref	Panel Stock Ref
Wired	9"	456165	456166	456168	456167
Wired	12"	456173	456174	456176	456175

* Wired refers to the controller type that can be utilised with the particular model.

Lo-Carbon T-Series Modular Option



Fitting Kit Options (excludes Fan Core)

Controller Type*	Size	Fan Core Stock Ref	Window Stock Ref	Wall Stock Ref	Roof Stock Ref	Panel Stock Ref
Wired	9"	472039	472047	472043	472055	472051
Wired	12"	472040	472048	472044	472056	472052

* Wired refers to the controller type that can be utilised with the particular model.

Lo-Carbon T-Series Window Fan

- Reduces your carbon footprint
- Extract/intake model in 2 sizes: 9" and 12"
- Long life Lo-Carbon motor lasts twice as long as conventional motors
- Up to 70% energy saving
- Easy fit connector Top Socket, standard on all models



UK's No. 1 Commercial Fan

The Lo-Carbon T-Series Fan range utilises a low energy DC motor, developed to improve performance, lower running costs and maintain T-Series' rugged reliability.

Window Fan

The fitting kit is designed for installation through single or double glazing and material up to 32mm thick. Greater thicknesses can be accommodated using extended fixing rod sets. Alternatively, the Lo-Carbon T-Series range can be used in conjunction with Vent-Axia ventilation accessories in flexible and rigid ducting systems to suit individual requirements. It can also be mounted in a fixing plate on walls or above ceilings.

Instantaneous Shutter

With energy saving in mind, units are supplied complete with an integral instantaneous automatic louvre shutter concealed behind the interior grille. It operates on both extract and intake and at any angle of mounting.

The shutter is electronically controlled by an actuator with a damped action giving quiet operation during instant opening and closing. The interlocking edges of the shutter blades provide maximum back draught protection. When the fan is used with the Lo-Carbon T-Series controller, the shutter can be set open with the fan motor switched Off to provide natural ventilation without the security risk of an open window.

Top Socket

A connector Top Socket is standard on all T-Series fans. Allowing fast and trouble-free mains connection.

Models

Complete Fan

Model	Stock Ref
9" Wired	456165
12" Wired	456173

Fan Core (excludes Window Kit)

Model	Stock Ref
9" Wired	472039
12" Wired	472040

Window Kit (excludes Fan Core)

Model	Stock Ref
9" Wired	472047
12" Wired	472048

Accessory

Extended Fixing Rod set

Size	Stock Ref
9"	568104
12"	568106

Controller



Models	Stock Ref
Wired	455873

Dimensions (mm)

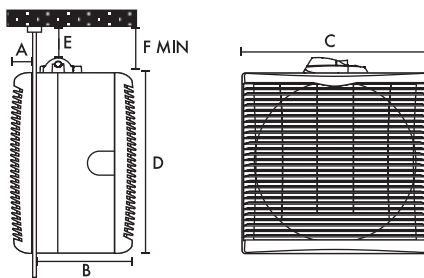

Size Dim.	9 in	12 in
A	39	41
B	150	177
C	304	381
D	302	378
E	19	19
F	54	54
Fixing hole Ø	260	337
Weight kg*	5.35	7.7

*Complete product. Controller (W x H x D) 97 x 99 x 32

Performance Guide

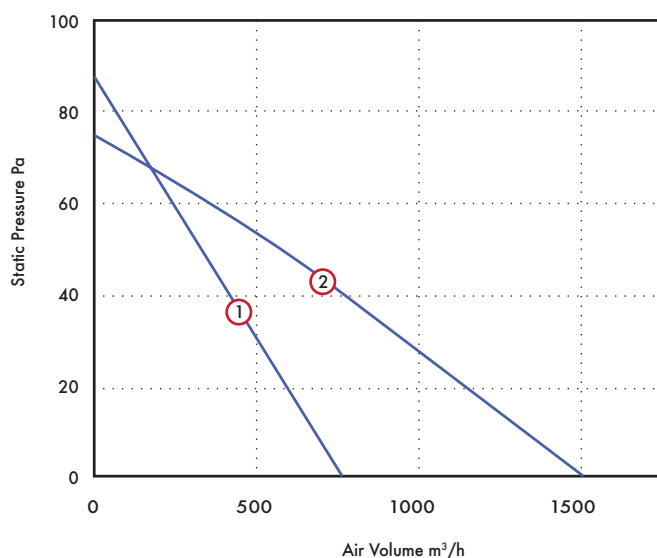

Model	Curve	Extract performance m³/h (l/s)			Watts (high)	Sound dB(A) (med) @ 3m	Amps @ 240V
		low	medium	high			
Lo-Carbon 9" Window - Wired	①	332 (90)	571 (160)	761 (210)	30.8	40	0.35
Lo-Carbon 12" Window - Wired	②	660 (185)	1295 (360)	1550 (430)	68.6	46	0.73

Lo-Carbon T-Series Wall Fan

- Long life Lo-Carbon motor lasts twice as long as conventional motors
- Reduces your carbon footprint
- Extract/intake model in 2 sizes: 9" and 12"
- Up to 70% energy saving
- Easy fit connector Top Socket, standard on all models



UK's No. 1 Commercial Fan

The Lo-Carbon T-Series Fan range utilises a low energy DC motor, developed to improve performance, lower running costs and maintain T-Series' rugged reliability.

Wall Fan

Lo-Carbon T-Series wall models are designed to fit directly into double brick, solid and cavity walls. The two part telescopic liner accommodates wall thicknesses from 240 to 315mm. For thicker walls additional liner sections are available. Lo-Carbon T-Series wall models are provided with internal and external wall frames which fit flush with both faces of the wall.

Instantaneous Shutter

Lo-Carbon T-Series models are supplied complete with an integral instantaneous automatic louvre shutter which will operate on both intake and extract and at any angle of mounting.

When the fan is used with a Lo-Carbon T-Series controller, the shutter can be set open with the fan motor switched Off to provide natural ventilation without the security risk of an open window.

Electrical

Motor purpose-designed. Suitable for running at any angle. Quiet running. Suitable for operation in ambient temperatures from -40°C to +50°C.

Fitted with self resetting Standard Thermal Overload Protection (S.T.O.P.).

Supply voltage 220-240V/1/50Hz.

Top Socket

A connector Top Socket is standard on all T-Series fans. Allowing fast and trouble-free mains connection.

Models

Complete Fan

Size	Stock Ref
9" Wired	456166
12" Wired	456174

Fan Core (excludes Wall Kit)

Size	Stock Ref
9" Wired	472039
12" Wired	472040

Wall Kit (excludes Fan Core)

Size	Stock Ref
9" Wired	472043
12" Wired	472044

Accessory

Additional Wall Liner Section

Size	Stock Ref
9"	460096
12"	460086

Controller



Models	Stock Ref
Wired	455873

Dimensions (mm)

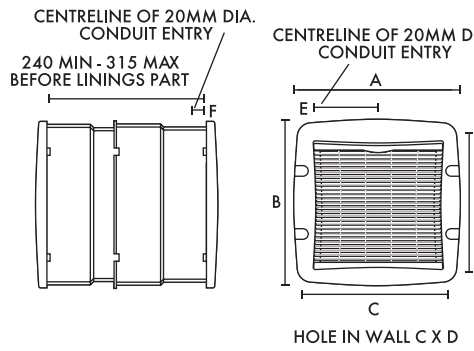

Size Dim.	9 in	12 in
A	391	470
B	388	467
C	365	442
D	375	450
E	143	182
F	25	25
Weight kg*	7.77	10.86

*Complete product. Controller (W x H x D) 97 x 99 x 32

Performance Guide

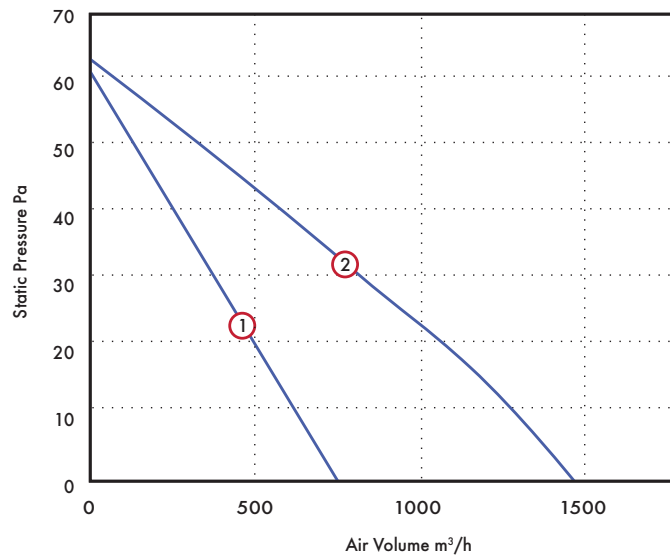

Model	Curve	Extract performance m³/h (l/s)			Watts (high)	Sound dB(A) (med) @ 3m	Amps @ 240V
		low	medium	high			
Lo-Carbon 9" Wall - Wired	①	326 (90)	562 (160)	732 (210)	27	39	0.31
Lo-Carbon 12" Wall - Wired	②	660 (185)	1355 (360)	1650 (430)	68	48	0.70

Lo-Carbon T-Series Roof Fan

- Reduces your carbon footprint
- Extract / intake model in 2 sizes: 9" and 12"
- Long life Lo-Carbon motor lasts twice as long as other conventional motors
- Up to 70% energy saving
- Easy fit connector Top Socket, standard on all models



UK's No. 1 Commercial Fan

The Lo-Carbon T-Series Fan range utilises a low energy DC motor, developed to improve performance, lower running costs and maintain T-Series' rugged reliability.

Roof Fitting Kit

Designing ventilation systems with the unit mounted in a skylight or a flat roof is easy. With a low profile cowl, the Lo-Carbon T-Series Roof model is suitable for installation in horizontal, angled (max pitch 30deg) and vertical glass and for fixing plates in roofs. For vertical windows or walls in exposed areas and single and double glazing including most types of glass up to 32mm thick. Greater thicknesses can be accommodated using extended fixing rod sets. Both sizes of Vent-Axia roof plate assemblies can be fitted easily into flat roofs.

Instantaneous Shutter

With energy saving in mind, Lo-Carbon T-Series models are supplied complete with an integral, instantaneous, automatic louvre shutter concealed behind the interior grille.

It will operate on both intake and extract and at any angle of mounting. The shutter is electronically controlled by an actuator with a damped action giving quiet operation during instant opening and closing.

When the fan is used with a Lo-Carbon T-Series controller, the shutter can be set open with the fan motor switched off to provide natural ventilation without the security risk of an open window.

Top Socket

A connector Top Socket is standard on all T-Series fans. Allowing fast and trouble-free mains connection.

Electrical

Motor purpose-designed. Suitable for running at any angle. Quiet

running, enclosed. Suitable for operation in ambient temperatures from -40°C to +50°C.

Fitted with self resetting Standard Thermal Overload Protection (S.T.O.P.).

Supply voltage 220-240V/1/50Hz.

Models

Complete Fan

Model	Stock Ref
9" Wired	456168
12" Wired	456176

Fan Core (excludes Roof Kit)

Size	Stock Ref
9" Wired	472039
12" Wired	472040

Roof Kit (excludes Fan Core)

Size	Stock Ref
9" Wired	472055
12" Wired	472056

Controller



Models	Stock Ref
Wired	455873

Dimensions (mm)

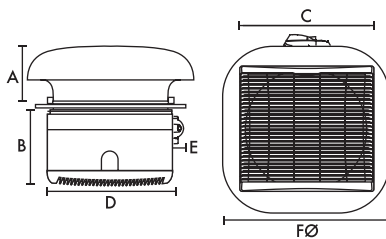

Size Dim.	9 in	12 in
A	136	171
B	150	177
C	304	381
D	302	378
E	54	54
FØ	400	500
Fixing Hole	260	337
Weight kg*	6.22	9.28

*Complete product. Controller (W x H x D) 97 x 99 x 32

Performance Graph

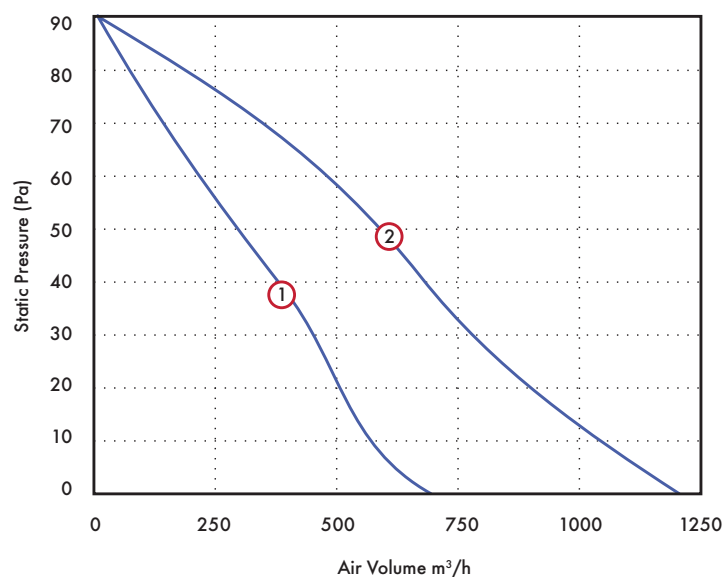

Model	Curve	Extract performance m³/h (l/s)			Watts (high)	Sound dB(A) (med) @ 3m	Amps @ 240V
		low	medium	high			
Lo-Carbon 9" Roof - Wired	①	313 (85)	562 (155)	693 (190)	27	40	0.34
Lo-Carbon 12" Roof - Wired	②	518 (143)	1017 (282)	1194 (330)	67	48	0.69

Lo-Carbon T-Series Panel Fan

- Reduces your carbon footprint
- Extract / intake model in 2 sizes: 9" and 12"
- Long life Lo-Carbon motor last twice as long as other conventional motors
- Up to 70% energy saving
- Easy fit connector Top Socket, standard on all models



UK's No. 1 Commercial Fan

The Lo-Carbon T-Series Fan range utilises a low energy DC motor, developed to improve performance, lower running costs and maintain T-Series' rugged reliability.

Panel Fitting Kit

Lo-Carbon T-Series panel/ceiling models are suitable for mounting at any angle in internal partitions, ceilings, ducts and, with louvre grilles, through external walls. When installed only the louvre grille is visible.

Instantaneous Shutter

With energy saving in mind, Lo-Carbon T-Series models are supplied complete with an integral instantaneous automatic louvre shutter concealed behind the interior grille. With a Lo-Carbon T-Series Controller the fan will operate on both extract and intake, suitable for any angle of mounting. When the fan is used with a Lo-Carbon T-Series controller, the shutter can be set open with the fan motor switched off to provide natural ventilation without the security risk of an open window.

Top Socket

A connector Top Socket is standard on all T-Series fans. Allowing fast and trouble-free mains connection.

Electrical

Suitable for operation in ambient temperatures from -40°C to +50°C.

Fitted with self resetting Standard Thermal Overload Protection (S.T.O.P).
Supply voltage: 220-240V/1/50Hz.

Easy Cleaning

Integrated component design allows all parts to be dismantled for cleaning without the use of specialist tools.

Models

Complete Fan

Size	Stock Ref
9" Wired	456167
12" Wired	456175

Fan Core (excludes wired Panel Kit)

Size	Stock Ref
9" Wired	472039
12" Wired	472040

Panel Kit (excludes Fan Core)

Size	Stock Ref
9" Wired	472051
12" Wired	472052

Controller



Models	Stock Ref
Wired	455873

Dimensions (mm)

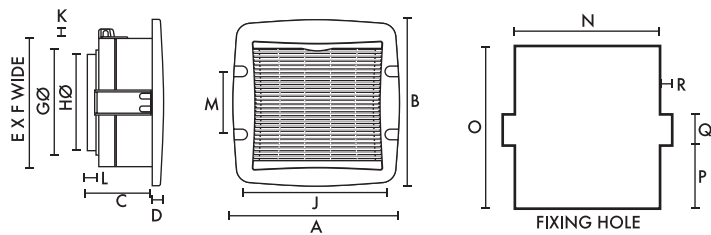

Size	9 in	12 in	Size	9 in	12 in
A	391	470	J	345	422
B	388	467	K	19	19
C	129	152	L	22	22
D	39	41	M	180	180
E	302	378	N	309	386
F	304	381	O	326	402
GØ	255	334	P	126	164
HØ	247	325	Q	55	55

Weight kg*: 9mm - 5.13, 12mm - 7.44

*Complete product. Controller (W x H x D) 97 x 99 x 32

Performance Guide

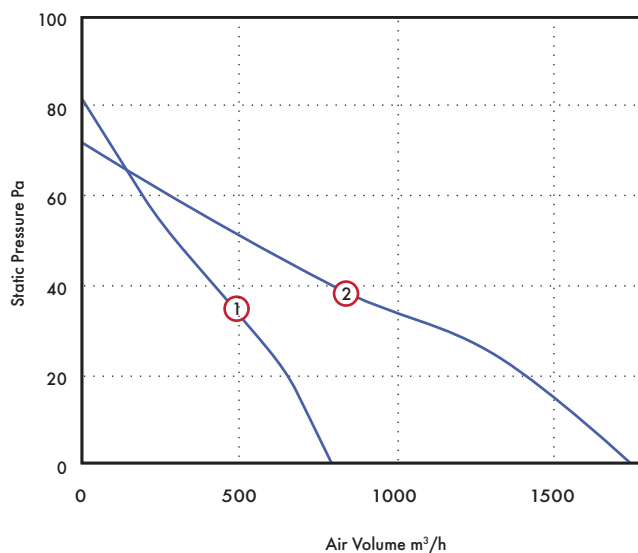

Model	Curve	Extract performance m³/h (l/s)			Watts (high)	Sound dB(A) (med) @ 3m	Amps @ 240V
		low	medium	high			
Lo-Carbon 9" Panel - Wired	1	357 (100)	601 (166)	799 (221)	30	41	0.33
Lo-Carbon 12" Panel - Wired	2	737 (205)	1487 (413)	1761 (490)	67	48	0.70

Traditional T-Series Range Overview

- Available as wall, window, panel, roof, inline or Darkroom models
- Available as a complete unit or modular fan core and fitting kit for refurbishments
- Flexible installation design
- Simple installation



ErP Regulations

The introduction of the ErP regulations gave us the opportunity to review our product ranges and has enabled us to improve the way we stock and sell them. You can still buy the market leading T-Series in the same way you always have, as a complete product, however we have taken the opportunity to add a more flexible option if you need it. We have introduced a modular option for refurbishment situations where you may not want to replace the whole product.

For new build projects and complete building refits the market leading T-Series is unchanged and available as a complete unit generally supplied in one carton.

For refurbishment markets, supplying as separate core and specific fitting kit gives more flexibility in both stocking and installing the product. This also gives the lowest overall cost to refurbish your fan system without changing wiring or controls, furthermore it also supports our Lo-Carbon drive to reduce waste and landfill.

Complete Product Option

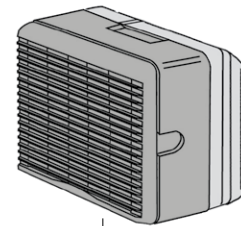

Complete product

Modular option

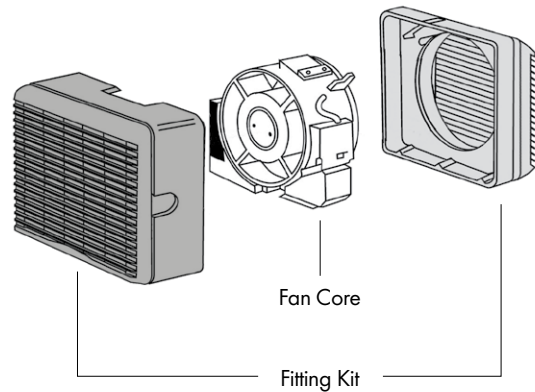

Traditional T-Series Complete Fan

						
Size	Window Stock Ref	Wall Stock Ref	Roof Stock Ref	Panel Stock Ref	Darkroom Stock Ref	In-line Stock Ref
6"	W161110	W161510	W161210	W161610	W161240	W161710
7"	W162110	W162510	W162210	W162610	W162240	N/A
9"	W163110	W163510	W163210	W163610	W163240	W163710
12"	W164110	W164510	W164210	W164610	W164240	W164710

Traditional T-Series Modular Option



Fitting Kit Options (excludes Fan Core)

Size	Fan Core Stock Ref	Fitting Kit Options (excludes Fan Core)					
		Window Stock Ref	Wall Stock Ref	Roof Stock Ref	Panel Stock Ref	Darkroom Stock Ref	In-line Stock Ref
6"	472012	472020	472016	472028	472024	472032	472036
7"	472013	472021	472017	472029	472025	472033	N/A
9"	472014	472022	472018	472030	472026	472034	472037
12"	472015	472023	472019	472031	472027	472035	472038

Traditional T-Series Window Fan

- Extract/intake fans in 4 sizes: 6", 7", 9" and 12"
- Patented electronic shutter system ensures quiet, trouble free operation
- To obtain the best from your fan, use the Ecotronic controller
- Shutter open/fan off mode
- Low sound levels
- Easy fit connector Top Socket, standard on all models
- Designed for single or double glazing up to 32mm thick



UK's No. 1 Commercial Fan

The T-Series fan range is fitted with a Vent-Axia M-Tech motor, developed to improve performance, lower running costs and maintain the T-Series' rugged reliability. A patented speed control pack is simply plugged in one of 3 positions to provide low, medium or boost speed matching the fan performance to the requirements of the installation.

Instantaneous Shutter

With energy saving in mind T-Series Fitting Kits are supplied complete with an integral instantaneous automatic louvre shutter concealed behind the interior grille. It operates on both extract and intake and at any angle of mounting.

When the fan is used with a T-Series or Ecotronic controller, the shutter can be set open with the fan motor switched off to provide natural ventilation without the security risk of an open window.

Top Socket

A connector Top Socket is standard on all T-Series fans allowing fast and trouble-free mains connection.

Easy Cleaning

Integrated component design allows all parts to be dismantled for cleaning without the use of specialist tools.

Electrical

Motor purpose-designed. Suitable for running at any angle. Quiet running. Suitable for operation in ambient temperatures from -40°C to +50°C.

Fitted with Standard Thermal Overload Protection (S.T.O.P.).

Supply voltage 220-240V/1/50Hz.

Window Kit

Designed for use in single or double glazing, most types of glass and materials up to 32mm thick. Greater thicknesses can be accommodated using Extended Fixing Rod Sets. Can also be mounted in a fixing plate or wall, in ducts or above ceilings.

Models

Complete Fan

Model	Stock Ref
TX6WW	W161110
TX7WW	W162110
TX9WW	W163110
TX12WW	W164110

Fan Core (excludes Fitting Kit)

Size	Stock Ref
TX6	472012
TX7	472013
TX9	472014
TX12	472015

Window Kits (excludes Fan Core)

Size	Stock Ref
TX6	472020
TX7	472021
TX9	472022
TX12	472023

Accessories

Extended Fitting Rod set

Size	Stock Ref
6/7/9"	568104
12"	568106

Controllers



Ecotronic Controller Surface Mounting

Stock Ref

W362320



T-Series Controller Surface Mounting

Stock Ref

W361119

Dimensions (mm)

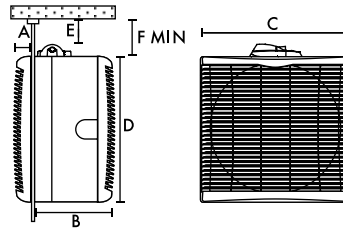

Size Dim.	6 in	7 in	9 in	12 in
A	31	31	39	41
B	130	130	150	177
C	226	265	304	381
D	220	258	302	378
E	19	19	19	19
F	54	54	54	54
Fixing hole Ø	184	222	260	337
Weight kg*	3.57	3.93	5.35	7.7

*Complete product.

Performance Guide

Model	Extract performance m ³ /h (l/s)			Watts (high)	Sound dB(A) (med) @ 3m	Amps @ 240V
	low	medium	high			
TX6 Window	245 (68)	315 (88)	360 (100)	30	41	0.24
TX7 Window	305 (85)	395 (110)	485 (135)	40	37	0.24
TX9 Window	465 (130)	685 (190)	795 (220)	85	43	0.42
TX12 Window	1095 (305)	1415 (393)	1615 (449)	105	48	0.51

Traditional T-Series Wall Fan

- Extract/intake model in 4 sizes: 6", 7", 9" and 12"
- Patented electronic shutter system ensures quiet, trouble free operation
- For the very best from your fan use the Ecotronic controller
- Easy fit connector Top Socket, standard on all models



UK's No. 1 Commercial Fan

Behind the grille of the Vent-Axia T-Series Wall model is a range of high performance extract/intake fans designed to fit through most wall thicknesses using telescopic liners supplied.

T-Series also features a unique speed control pack which enables high, medium or low speed to be preset to suit room size or required duty.

T-Series controllers may be used with this model to obtain a choice of speeds, reversible airflow direction and automatic sensor operation. The Vent-Axia Ecotronic controller gives even greater running economy with its minimum speed setting and 'E' mode.

Top Socket

A connector Top Socket is standard on all T-Series fans. Allowing fast and trouble-free mains connection.

Shutter

TX models are supplied complete with an integral instantaneous automatic louvre shutter which will operate on both intake and extract and at any angle of mounting.

When the fan is used with a T-Series or Ecotronic controller, the shutter can be set open with the fan motor switched off to provide natural ventilation without the security risk of an open window.

Electrical

Motor purpose-designed. Suitable for running at any angle. Quiet running, enclosed. Suitable for operation in ambient temperatures from -40°C to +50°C.

Fitted with Standard Thermal Overload Protection (S.T.O.P.).

Supply voltage 220-240V/1/50Hz.

Wall Kits

Designed to fit into most double brick walls using the telescopic liners, supplied. Additional liners are available to accommodate exceptionally thick brick walls.

Models

Complete Fan

Model	Stock Ref
TX6WL	W161510
TX7WL	W162510
TX9WL	W163510
TX12WL	W164510

Fan Core (excludes Fitting Kit)

Size	Stock Ref
TX6	472012
TX7	472013
TX9	472014
TX12	472015

Wall Kits (excludes Fan Core)

Size	Stock Ref
TX6	472016
TX7	472017
TX9	472018
TX12	472019

Accessories

Additional Wall Liner Section

Size	Stock Ref
TX6	460094
TX7	460095
TX9	460096
TX12	460086

Controllers



Ecotronic Controller Surface Mounting

Stock Ref

W362320



T-Series Controller Surface Mounting

Stock Ref

W361119

Dimensions (mm)

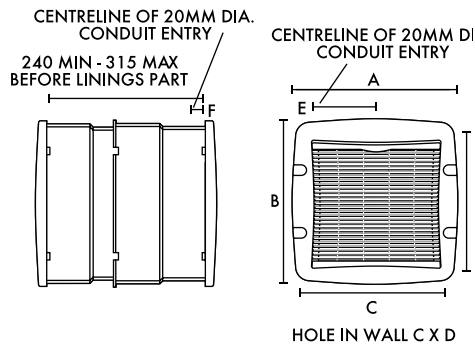

Size Dim.	6 in	7 in	9 in	12 in
A	310	352	391	470
B	303	345	388	467
C	290	330	365	442
D	290	330	375	450
E	104	124	143	182
F	25	25	25	25
Weight kg	5.54	6.13	7.77	10.86

* Complete product.

Performance Guide

Model	Extract performance m ³ /h (l/s)			Watts (high)	Sound dB(A) (med) @ 3m	Amps @ 240V
	low	medium	high			
TX6 Wall	270 (75)	350 (97)	395 (110)	40	43	0.24
TX7 Wall	335 (93)	435 (120)	530 (147)	40	39	0.24
TX9 Wall	515 (143)	755 (210)	870 (241)	85	43	0.42
TX12 Wall	1185 (329)	1530 (425)	1745 (485)	105	49	0.51

Traditional T-Series Roof Fan

- Extract/intake model in 4 sizes: 6", 7", 9" and 12"
- Patented electronic shutter system ensures quiet, trouble free operation
- For the very best from your fan use the Ecotronic controller
- T-Series controllers and sensors save energy by only switching on the units when you want, either manually or automatically
- Easy fit connector Top Socket, standard on all models



UK's No. 1 Commercial Fan

With a low profile cowl, the T-Series Roof model is suitable for installation in horizontal, angled (max pitch 30deg) and vertical glass and for fixing plates in roofs. For vertical windows or walls in exposed areas and single or double glazing including most types of glass up to 32mm thick. Greater thicknesses can be accommodated using extended fixing rod sets. All four sizes of Vent-Axia roof plate assemblies can be fitted easily into flat roofs.

T-Series features a unique speed control pack which enables high, medium or low speed to be preset to suit room size or required duty. When used with a T-Series TSC controller, the speed control pack is removed from the T-Series fan and fitted into the 3-pin socket in the back of the controller. The Vent-Axia Ecotronic controller gives even greater running economy with its minimum speed setting and 'E' mode. When using the Ecotronic controller the speed control pack remains in the fan.

Shutter

With energy saving in mind, T-Series Fitting Kits are supplied complete with an integral instantaneous automatic louvre shutter concealed behind the interior grille. It will operate on both intake and extract and at any angle of mounting.

When the fan is used with a T-Series or Ecotronic controller, the shutter can be set open with the fan motor switched off to provide natural ventilation without the security risk of an open window.

Electrical

Motor purpose-designed. Suitable for running at any angle. Quiet running, enclosed. Suitable for operation in ambient temperatures from -40°C to +50°C.

Fitted with Standard Thermal Overload Protection (S.T.O.P.).

Supply voltage 220-240V/1/50 Hz.

Top Socket

A connector Top Socket is standard on all T-Series fans. Allowing fast and trouble-free mains connection.

Models

Complete Fan

Model	Stock Ref
TX6RF	W161210
TX7RF	W162210
TX9RF	W163210
TX12RF	W164210

Fan Core (excludes Fitting Kit)

Size	Stock Ref
TX6	472012
TX7	472013
TX9	472014
TX12	472015

Roof Kit (excludes Fan Core)

Size	Stock Ref
TX6	472028
TX7	472029
TX9	472030
TX12	472031

Controllers



Ecotronic Controller Surface Mounting

Stock Ref

W362320



T-Series Controller Surface Mounting

Stock Ref

W361119

Dimensions (mm)

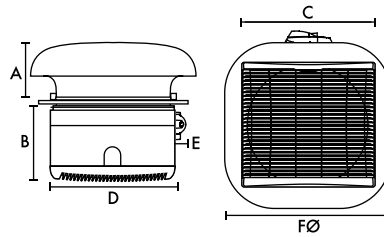

Size Dim.	6 in	7 in	9 in	12 in
A	100	136	136	171
B	130	130	150	177
C	226	265	304	381
D	220	258	302	378
E	54	54	54	54
F Ø	285	400	400	500
Fixing Hole Ø	184	222	260	337
Weight kg*	3.96	4.89	6.22	9.28

* Complete product.

Performance

Model	Extract performance m ³ /h (l/s)			Watts (high)	Sound dB(A) (med) @ 3m	Amps @ 240V
	low	medium	high			
TX6 Roof	195 (55)	250 (70)	290 (80)	30	41	0.24
TX7 Roof	305 (85)	395 (110)	485 (135)	40	37	0.24
TX9 Roof	465 (130)	685 (190)	795 (220)	85	43	0.42
TX12 Roof	1010 (280)	1305 (362)	1485 (412)	105	48	0.51

Traditional T-Series Panel/Ceiling Fan

- Extract/intake model in 4 sizes: 6", 7", 9" and 12"
- Colour: soft tone grey
- Patented electronic shutter system ensures quiet, trouble-free operation
- For the very best from your fan use the Ecotronic controller
- East fit connector Top Socket, standard on all models



UK's No. 1 Commercial Fan

Vent-Axia T-Series Panel/Ceiling models are suitable for mounting at any angle in internal partitions, ceilings, ducts and, with louvre grilles, through external walls. When installed only the louvre grille is visible. The range features a unique speed control pack which enables high, medium or low speed to be preset to suit a specific room size or required duty.

T-Series controllers may be used with this model to obtain a choice of speeds, reversible airflow direction and automatic sensor operation. When used with a controller, the speed control pack is removed from the T-Series fan and fitted into the 3-pin socket in the back of the controller. The Vent-Axia Ecotronic controller gives even greater running economy with its minimum speed setting on 'E' mode and infinitely variable speed control. For this controller the speed control pack remains in the fan.

Electrical

Suitable for operation in ambient temperatures from -40°C to +50°C.

Fitted with Standard Thermal Overload Protection (S.T.O.P).

Supply voltage: 220-240V/1/50Hz.

Top Socket

A connector Top Socket is standard on all T-Series fans allowing fast and trouble-free mains connection.

Shutter

With energy saving in mind, panel/ceiling kits are supplied complete with an integral instantaneous automatic louvre shutter concealed behind the interior grille. It will operate on both intake and extract and at any angle of mounting.

When the fan is used with a T-Series or Ecotronic controller, the shutter can be set open with the fan motor switched off to provide natural ventilation without the security risk of an open window.

Models

Complete Fan

Model	Stock Ref
TX6PL	W161610
TX7PL	W162610
TX9PL	W163610
TX12PL	W164610

Fan Core (excludes Fitting Kit)

Size	Stock Ref
TX6	472012
TX7	472013
TX9	472014
TX12	472015

Panel/Ceiling Kit (excludes Fan Core)

Size	Stock Ref
TX6	472024
TX7	472025
TX9	472026
TX12	472027

Controllers



Ecotronic Controller Surface Mounting

Stock Ref
W362320



T-Series Controller Surface Mounting

Stock Ref
W361119

Dimensions (mm)

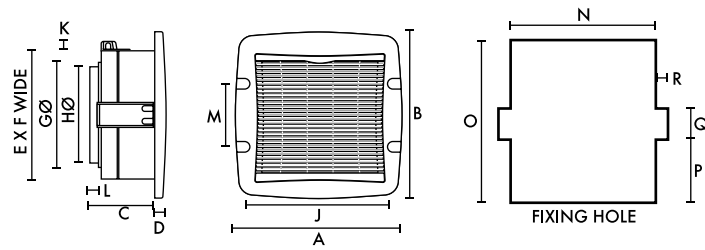

Size Dim.	6 in	7 in	9 in	12 in
A	310	352	391	470
B	303	345	388	467
C	117	117	129	152
D	32	32	39	41
E	220	258	302	378
F	226	265	304	381
GØ	180	218	255	334
HØ	171	210	247	325
J	267	306	345	422
K	19	19	19	19
L	22	22	22	22
M	180	180	180	180
N	231	270	309	386
O	244	282	326	402
P	85	104	126	164
Q	55	55	55	55
R	12	12	12	12
Weight kg*	3.50	3.82	5.13	7.44

* Complete product.

Performance Guide

Model	Extract performance m ³ /h (l/s)			Watts (high)	Sound dB(A) (med) @ 3m	Amps @ 240V
	low	medium	high			
TX6 Panel/Ceiling	295 (81)	380 (105)	435 (120)	30	41	0.24
TX7 Panel/Ceiling	365 (101)	480 (133)	585 (162)	40	37	0.24
TX9 Panel/Ceiling	565 (157)	830 (230)	960 (267)	85	43	0.42
TX12 Panel/Ceiling	1270 (353)	1640 (456)	1885 (524)	105	44	0.51

Traditional T-Series Darkroom Fan

- Extract/intake models in 4 sizes: 6", 7", 9" and 12"
- Specially designed to provide extract/intake ventilation in darkrooms, X-ray areas, etc
- Patented electronic shutter system ensures quiet, trouble free operation
- For the very best from your fan use the Ecotronic controller
- Integrated component design allows all parts to be dismantled for cleaning without the use of specialist tools
- Easy fit connector Top Socket, standard on all models



UK's No. 1 Commercial Fan

A range designed for photographic, medical, dental and veterinarian applications, also for opticians and other specialist applications. Most darkrooms need a minimum of ten air changes per hour for comfort and efficiency. For rooms containing heat producing equipment (eg: print glazers) a higher rate of air change may be desirable.

The Darkroom fitting kit has two cowls, the interior cowl being designed to give light protection. It can be installed in windows, partitions, external walls or roofs. Extended fixing rods for fixing thicknesses up to 370mm are supplied with the unit. Provision should be made for adequate air replacement through Vent-Axia non-vision grilles.

Shutter

With energy savings in mind Darkroom models are supplied complete with an integral instantaneous automatic louvre shutter concealed behind the interior cowl. Operates on intake and extract at any angle of mounting.

When used with a T-Series or Ecotronic controller, the shutter can be set open with the fan motor switched Off to provide natural ventilation without the security risk of an open window.

Top Socket

A connector Top Socket is standard on all T-Series fans. Allowing fast and trouble-free mains connection.

Electrical

Suitable for running at any angle. Quiet running, enclosed. Fitted with Standard Thermal Overload Protection (S.T.O.P.).

Supply voltage: 220-240V/1/50Hz.

Suitable for operation in ambient temperatures from -40°C to +50°C.

Models

Complete Fan

Model	Stock Ref
TX6DR	W161240
TX7DR	W162240
TX9DR	W163240
TX12DR	W164240

Fan Core (excludes Fitting Kit)

Size	Stock Ref
TX6	472012
TX7	472013
TX9	472014
TX12	472015

Darkroom Kit (excludes Fan Core)

Size	Stock Ref
TX6	472032
TX7	472033
TX9	472034
TX12	472035

Controllers



Ecotronic Controller Surface Mounting

Stock Ref
W362320



T-Series Controller Surface Mounting

Stock Ref
W361119

Dimensions (mm)

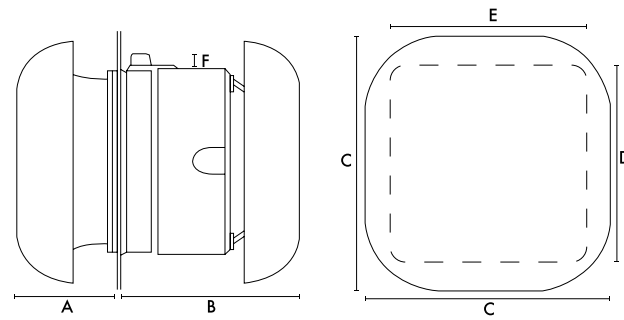

Size Dim.	6 in	7 in	9 in	12 in
A	100	136	136	171
B	196	206	229	308
C	285	400	400	500
D	220	258	302	378
E	226	265	304	381
F	19	19	19	19
Fixing Hole Ø	184	222	260	337
Weight kg*	4.13	5.33	6.60	10.05

*Complete product.

Performance Guide

Model	Extract performance m ³ /h (l/s)			Watts (high)	Sound dB(A) (med) @ 3m	Amps @ 240V
	low	medium	high			
TX6 Darkroom	200 (55)	240 (67)	265 (74)	30	43	0.24
TX7 Darkroom	330 (92)	415 (115)	530 (147)	40	42	0.24
TX9 Darkroom	455 (126)	630 (175)	725 (201)	85	45	0.42
TX12 Darkroom	870 (242)	1040 (289)	1130 (314)	105	42	0.51

Traditional T-Series In-Line Fan

- Extract/intake model in 3 sizes: 6", 9" and 12"
- Patented instantaneous electronic shutter system ensures quiet, trouble free operation
- For the best from your fan use the Ecotronic controller
- T-Series controllers and sensor save energy by only switching on the units when you want, either manually or automatically
- Easy fit connector Top Socket, standard on all models



UK's No. 1 Commercial Fan

No other range of high performance in-line duct fans offers a combination of 3 impeller diameters, reversibility, low sound level, speed control and built-in electric shutter. T-Series features a unique speed control pack which enables high, medium or low speed to be preset to suit room size or required duty. Designed for use with rigid or flexible ducting, T-Series In-Line models can be plate mounted or fixed through partitions and in ceiling voids.

T-Series controllers may be used with this model to obtain a choice of speeds, extract/intake airflow direction and automatic sensor operation. The Vent-Axia Ecotronic controller gives even greater running economy with its minimum speed setting and 'E' mode.

Top Socket

A connector Top Socket is standard on all T-Series fans. Allowing fast and trouble-free mains connection.

Shutter

The shutter is electronically controlled by an actuator with a damped action giving quiet operation during instant opening and closing. The interlocking edges of the shutter blades provide maximum back draught protection.

When the fan is used with a T-Series or Ecotronic controller, the shutter can be set open with the fan motor switched off to provide natural ventilation without the security risk of an open window.

Ducts

Where ducts pass through an unheated roof void, the duct should be insulated. Horizontal ducts should fall away from the fan unit. In circumstances where an excessive amount of moisture is present, a condensation trap should be installed in the exhaust duct. The fan unit should be accessible for regular maintenance.

Electrical

Suitable for operation in ambient temperatures from -40°C to +50°C.

Fitted with Standard Thermal Overload Protection (S.T.O.P.).

Supply voltage 220-240V/1/50 Hz.

Models

Complete Fan

Model	Stock Ref
TX6IL	W161710
TX9IL	W163710
TX12IL	W164710

Fan Core (excludes Fitting Kit)

Model	Stock Ref
TX6	472012
TX9	472014
TX12	472015

In-line Kit (excludes Fan Core)

Model	Stock Ref
TX6	472036
TX9	472037
TX12	472038

For use with rigid and flexible ducting. Can be plate-mounted or fixed to partitions and in ceiling voids.

Controllers



Ecotronic Controller Surface Mounting

Stock Ref

W362320



T-Series Controller Surface Mounting

Stock Ref

W361119

Dimensions (mm)

Sizes 6 & 9

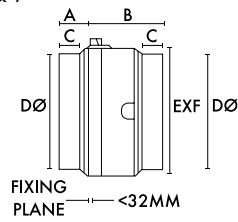

Size 12

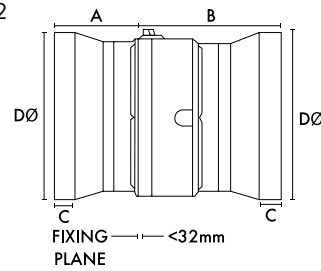

Size Dim.	6 in	9 in	12 in
A	75	71	200
B	175	183	337
C	45	41	45
DØ	175	300	400
E	220	302	378
F	226	304	381
Fixing Hole Ø	184	260	337
kg	4.5	8	11.5

Performance Guide

Model	Extract performance m ³ /h (l/s)			Watts (high)	Sound dB(A) (med) @ 3m	Amps @ 240V
	low	medium	high			
TX6 In-line	318 (88)	398 (110)	444 (123)	30	45	0.24
TX9 In-line	703 (195)	966 (268)	1050 (292)	85	47	0.42
TX12 In-line	1674 (465)	2000 (556)	2230 (620)	105	51	0.51

Super T-Series

- 4 impeller diameters 355, 400, 450, 500mm
- Complete with telescopic wall sleeve and shutter, ready for installation
- IP54 motor and terminal box
- Smart internal grille and external shutter with flange trim
- Super quiet operation
- For the very best performance from your fan, use the Vent-Axia 2.5 Amp electronic controller



Powerful Ventilation

Vent-Axia's Super T-Series 355, 400, 450 and 500mm fans provide efficient, quiet powerful ventilation with performances up to 4940m³/h. Tough heavy duty internal grilles and external weather shutters ensure longevity, performance and peace of mind.

Construction

The axial fan at the heart of the Super T range is based on an integrated impeller and internal rotor motor design which produces a very compact unit. A specially designed bellmouth inlet and mounting plate ensures an excellent performance to sound level ratio.

Electrical

Single phase 220-240V 50Hz. Capacitor start and run. An IP54 terminal box is supplied with all models with conduit entry from the side of the wall liner. All motors are fitted with Standard Thermal Overload Protection (S.T.O.P.), which should be wired via the controller.

Models

Super T - Gravity shutter

When installed, only the room side aluminium fascia grille is visible. The outside is finished with an external gravity shutter and frame.

Model	Stock Ref
ST355-16-WL	165510
ST400-16-WL	166510
ST450-16-WL	167510
ST500-16-WL	168510

Super T TX - Electric shutter

Super T TX extract or intake models with powerful, quiet, smooth-operation electric shutters.

Model	Stock Ref
STX355-16	165710
STX400-16	166710

STX450-16	167710
STX500-16	168710

Super T Filtered Air Input

Super T ARX and AR filtered passive air replacement input unit. Consisting of a wall liner with high capacity high disposable EU4 pleated filter which fits inside the wall liner.

ARX Models

With electronically controlled integral shutter AR Models - external louvre fixed blade.

Model	Stock Ref
Units with integral shutter	
STARX355-16	165810
STARX450-16	167810

Units with louvre fixed blades

STAR355-16	165910
STAR450-16	167910

Filtered Kitchen Extract - Super T GF

Super T GF extract unit without internal grille, but with matching stainless steel filter housing and tray kit ready for assembly on site and 50mm stainless steel framed mesh grease filter with handles.

Model	Stock Ref
STGF355-14	165620
STGF400-14	166620

Accessories

Replacement Grease Filters

Super T replacement grease filters 50mm stainless steel mesh filter with handles. Supplied in packs of two.

Model	Stock Ref
355	452550
400	452551

Replacement Air Filters

High capacity EU4 pleated filter which fits inside wall liner. Supplied in packs of five.

Model	Stock Ref
355	452814
450	452815

Electronic 2.5A Controller

Provides variable motor speed control. On/Off with indication light. Infinitely variable speed slider control. Presetable minimum speed and sensor mode option: can be connected to a range of Vent-Axia sensors. Radio suppressed to BS 800. Includes electric shutter output.

Stock Ref
W10303102M

Dimensions (mm)

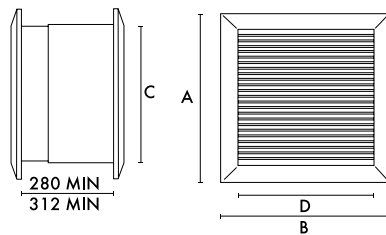

CxD SQ. HOLE THROUGH WALL

Impeller dia.	355	400	450	500
A	550	597	657	727
B	550	597	657	727
C	470	520	580	650
D	470	520	580	650
Weight kg	17	22	28	33

Performance Guide

Model	Extract Performance m ³ /h (l/s) F.I.D.	Watts	S.C. amps	F.L.C. amps	Sound dB(A) @ 3m
355-16	1800 (500)	130	1.38	0.6	40
400-16	2034 (565)	90	1.2	0.46	45
450-16	2561 (761)	100	1.4	0.48	48
500-16	4378 (1216)	360	3.6	1.6	51
355-14	2150 (597)	150	1.38	0.7	56
400-14	3500 (972)	190	1.45	0.84	59

Standard Range Spares Only



As the iconic Standard Range is being made obsolete after such a long life, we would like to provide answers to some of your questions.

Time line of the Standard Range

- Launched in 1958, with no significant design changes from inception to today.
- T-Series launched in 1986 and was designed as the Standard Range's replacement.
- 30 years later we still sell the Standard Range as well.
- In 2018 the Standard Range was 60 years old!
- We have tried to manage the end of the Standard Range as best we can to fully support our customers.

Why is it being discontinued?

The moulding method is very outdated and materials used in its production are coming to the end of their available life, with costs and lead times rising significantly. Tools are now at the end of life, at current volumes it is uneconomic to make new tools. Future regulation changes will eventually make this range obsolete.

What are my options when Standard Range is not available?

The T-Series was designed as a replacement. Most installations can be fitted with a T-Series instead of a Standard Range model with only a small amount of modification.

Please see the 'Fitting Guide for Replacing a Standard Range Installation with a T-Series Model' for full details explaining each model and the options/modifications that may be required on site.

My building is listed/I must keep the look of the existing Standard Range fan

We are supporting this type of request by keeping a limited range of key spares for the Standard Range. This will not cover any mouldings, fascias and grills but will cover the motor and impeller. You will be able to replace these key parts and keep the existing mouldings to extend the life of your Standard Range fan.

One of the moulded parts has been damaged/vandalised - will any spare mouldings be available?

Unfortunately not, however it is always worth a call to Technical Support with an image and size of the moulding required, they will then be able to investigate if there are any replacement mouldings available. Please note that we cannot guarantee this will be the case.

Fitting Guide for Replacing a Standard Range Installation with a T-Series Model

Modifications Required for Electrical Fit







Installation Type	Standard Range Fan Model	T-Series Fan Equivalent Fan Model	Mechanical Fit Modifications required	No Controller Fitted	Rangemaster Controller Fitted	Old style Rangemaster Controller with Boost Fitted	Further Comments	
Window No Shutter Fitted		S6WW > TX6WW		None	No wiring modification required. Follow T-Series installation instructions.	Remove the shutter assembly. Use existing controller. To make use of T-Series shutter, change to 5 core cable.	Replace controller with T-Series or Ecotronic controller. Remove the shutter assembly. To make use of T-Series shutter, change to 5 core cable - See controller instructions.	
		S7WW > TX7WW						
		S9WW > TX9WW						
		S12WW > TX12WW						
Window Shutter Fitted		S6WW > TX6WW		None	No wiring modification required. Follow T-Series installation instructions.	Can use existing controller. To make use of T-Series shutter, change to 5 core cable.	Replace controller with T-Series or Ecotronic controller. To make use of T-Series shutter, change to 5 core cable - See controller instructions.	
		S7WW > TX7WW						
		S9WW > TX9WW						
		S12WW > TX12WW						
Roof No Shutter Fitted		S6RF > TX6RF		None	No wiring modification required. Follow T-Series installation instructions.	Remove the shutter assembly. Use existing controller. To make use of T-Series shutter, change to 5 core cable.	Replace controller with T-Series or Ecotronic controller. Remove the shutter assembly. To make use of T-Series shutter, change to 5 core cable - See controller instructions.	
		S7RF > TX7RF						
		S9RF > TX9RF						
		S12RF > TX12RF						
Roof Shutter Fitted		S6RF > TX6RF		None	No wiring modification required. Follow T-Series installation instructions.	Can use existing controller. To make use of T-Series shutter, change to 5 core cable.	Replace controller with T-Series or Ecotronic controller. To make use of T-Series shutter, change to 5 core cable - See controller instructions.	
		S7RF > TX7RF						
		S9RF > TX9RF						
		S12RF > TX12RF						
Wall No Shutter Fitted		S6WL > TX6PL		Wall box is a different dimension, new fixings and cabling required.	Follow T-Series installation instructions.	Remove the shutter assembly. Use existing controller. To make use of T-Series shutter, change to 5 core cable.	Replace controller with T-Series or Ecotronic controller. Remove the shutter assembly. To make use of T-Series shutter, change to 5 core cable - See controller instructions.	Use Panel Fan model. Appropriate fixing screws should be used to secure Panel Fan through external wall.
		S7WL > TX7PL						
		S9WL > TX9PL						
		S12WL > TX12PL						
Wall Shutter Fitted		S6WL > TX6PL		Wall box is a different dimension, new fixings and cabling required.	Follow T-Series installation instructions.	Can use existing controller. To make use of T-Series shutter, change to 5 core cable.	Replace controller with T-Series or Ecotronic controller. To make use of T-Series shutter, change to 5 core cable - See controller instructions.	Use Panel Fan model. Appropriate fixing screws should be used to secure Panel Fan through external wall.
		S7WL > TX7PL						
		S9WL > TX9PL						
		S12WL > TX12PL						
Panel No Shutter Fitted		S6PL > TX6PL		New fixing and cut out modifications required. New cabling required.	Follow T-Series installation instructions.	Remove the shutter assembly. Use existing controller. To make use of T-Series shutter, change to 5 core cable.	Replace controller with T-Series or Ecotronic controller. Remove the shutter assembly. To make use of T-Series shutter, change to 5 core cable - See controller instructions.	None
		S7PL > TX7PL						
		S9PL > TX9PL						
		S12PL > TX12PL						
Panel Shutter Fitted		S6PL > TX6PL		New fixing and cut out modifications required. New cabling required.	Follow T-Series installation instructions.	Can use existing controller. To make use of T-Series shutter, change to 5 core cable.	Replace controller with T-Series or Ecotronic controller. To make use of T-Series shutter, change to 5 core cable - See controller instructions.	None
		S7PL > TX7PL						
		S9PL > TX9PL						
		S12PL > TX12PL						

Please contact Technical Support on 0344 856 0594 for any questions or issues.

Standard Range Spare Guide



Installation Type	Standard Range Fan Model	Motor	Impeller with Dwasher	Cone/ Impeller Nut	
Window		S6WW	444834	430763	430366
		S7WW	444835	430764	430366
		S9WW	444836	430765	430366
		S12WW	444837	430766	430366
Roof		S6RF	444834	430763	430366
		S7RF	444835	430764	430366
		S9RF	444836	430765	430366
		S12RF	444837	430766	430366
Wall		S6WL	444834	430763	430366
		S7WL	444835	430764	430366
		S9WL	444836	430765	430366
		S12WL	444837	430766	430366
Panel		S6PL	444834	430763	430366
		S7PL	444835	430764	430366
		S9PL	444836	430765	430366
		S12PL	444837	430766	430366

Please contact Technical Support on 0344 856 0594 for any questions or issues.

Accessories

Standard Range impeller with D washer



Size	Stock Ref
6" All models	430763
7" All models	430764
9" All models	430765
12" All models	430766

Note:
Please ensure you keep the impeller cone nut from the original unit.

Standard Range motor assembly



Size	Stock Ref
6" All models	444834
7" All models	444835
9" All models	444836
12" All models	444837

Note:
Please ensure you keep the impeller cone nut from the original unit.
Please ensure you keep the motor cone nut and washers from the original unit. Please ensure you keep all electrical connector sockets and internal lead assemblies from the original unit.

Hygiene



Vent-Axia has been at the forefront of technical innovation for over 80 years and we understand that hand dryer hygiene is essential in our daily lifestyles. We have an extensive hand dryer range suitable for use in many locations, from pubs and restaurants to hotels, schools, service stations and retail centres.

Each of our hand dryer products is powerful yet quiet and all our models come in sleek, elegant designs to blend well into any kitchen, bathroom or WC location. From the powerful fast-speed JetDry Plus to the classic Turbodry, our hand dryer products are all designed with energy efficiency firmly in mind, saving you as much as 70% of the equivalent cost of paper towels.

For any situation where hygiene, convenience, economy and safety are all key considerations, you can trust Vent-Axia's hand dryer range to deliver the solutions you need.

Jet Dry® Plus

The Jet Dry Plus features a 99.9% HEPA filter and UV sterilization for use in areas where good hygiene is vital.

Vent-Axia®



Restroom

	Jet Dry® Plus	I:3
	Jet Dry® Junior	I:3
	Tempest®	I:3
	Lo-Carbon eTempest	I:3
	Ultradry® SX Stainless Steel	I:4
	Prepdry	I:4
	Professional E®	I:4
	Easy Dry	I:5
	Insect Killers	I:5
	Touchless Sensor Operated Hand Sanitiser/Soap Dispenser	I:5

Fast Dry Hand Dryers



Jet Dry® Plus

Automatic double sided, high speed dryer, for high traffic settings.

- 99.9% HEPA filter
- UV sterilisation
- 10 second drying time
- LED indicator
- Removable drip tray
- Air speed 95m/s
- Low carbon DC motor, as low as 750W to 2050W
- Heater element 900W - 1300W, adjustable on/off
- 700 x 300 x 225mm (H x W x D)
- Weight 9.5kg
- IPX4 rated
- Sound level: 75dB(A) at 1m
- Cable entry bottom right
- Three-year warranty
- Ambient temperature response element
- Antibacterial coating
- GS approved



Models
Silver

Stock Ref
409117



Jet Dry® Junior

Automatic double sided, high speed dryer, for low traffic settings.

- 99.9% HEPA filter
- UV Sterilisation
- 10-12 second drying time
- LED indicator
- Removable drip tray
- Air speed 150m/s
- Brushed motor, as low as 1250W to 1650W
- Heater element 400W adjustable on/off
- 671 x 279 x 195mm (H x W x D)
- Weight 8.8kg
- IP23 rated
- Sound level: 75dB(A) at 1m
- Cable entry bottom right
- Two-year warranty



Models
Silver

Stock Ref
497992

Lo-Carbon eTempest

Automatic hand dryer for fast drying applications.

- 10 second drying time
- Air speed: 52-90 m/s, adjustable
- Infrared automatic operation
- Unique blue dry zone indicator
- Automatically senses work surfaces to avoid nuisance running
- Cover: Steel 1.2 mm thick, epoxy coated
- Insulation Earthed Class 1
- Heater element 500W adjustable on/off
- Rated at 500kW - 1.2 kW at 230V
- Weight: 3.8Kg
- 180 x 250 x 138.5mm (H x W x D)
- 60 seconds auto shut off
- Soft start
- IPX1 rated
- GS approved
- Cable entry bottom left
- Motor: Max 30,000rpm brushed motor



Model
White

Stock Ref
444956

Tempest® - Reduced Sound

Automatic no-touch hand dryer for heavy duty applications.

- 10 second drying time
- Air speed: 75-100 m/s, adjustable
- Infrared automatic operation
- Unique blue dry zone indicator
- Automatically senses work surfaces to avoid nuisance running
- Cover: Steel. Finish: Polished or satin stainless steel
- Insulation Earthed Class 1
- Heater element 450 - 900W, adjustable on/off
- Rated at 500W - 1.6kW at 230V
- Weight 6.6kg (packaged)
- 277 x 201 x 175mm (H x W x D)
- 60 second auto shut off
- Soft start
- IP23 rated
- GS approved
- Cable entry bottom left
- Motor: Max 18,000rpm brushed motor
- Motor speed adjustable
- Sound level: reduced to 72dB(A) at 1m



Models

Stock Ref

Satin Stainless	439464
Polished Stainless	439463
White	437231
Filter Assembly Pack	444959
Filter Replacement 2 pack	444960

Hand Dryers



Professional E®

Automatic 'no-touch' hand dryer for smaller office washrooms, kitchens and clinics.

- Cover and base: High gloss, fire retardant ABS/polycarbonate alloy
- Motor: 2700rpm external rotor, brushless motor
- Double insulated appliance
- 262 x 261 x 141mm (H x W x D)
- Weight: 3.09kg (3.52kg packed)
- Sound level: 65 dB(A) at 1m
- Rated at: 2.0 kW at 240V
- 31 second drying time
- BEAB Approved
- Supply voltage: 220-240V/1/50Hz
- IP24 Rated
- Cable entry bottom right



Stock Ref

20101402

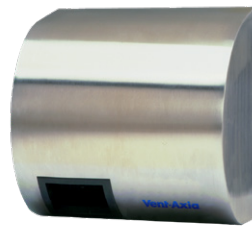

Ultradry® SX Stainless Steel

Automatic 'no-touch' hand dryer specially designed for high performance hand drying in food preparation areas and hospital applications and eminently suitable for prestige installations.

- Cover: Satin polished stainless steel
- Motor: 5,500rpm, suppressed brushed motor
- Insulation Earthed Class 1
- 264 x 275 x 177mm (H x W x D)
- Weight: 6.0kg (6.6kg packed)
- Sound level: 79 dB(A) at 1m
- Rated at: 2.4kW at 230V
- 28 second drying time
- BEAB Approved
- IP24 Rated
- Cable entry bottom right



Stock Ref

20101840SX



Prepdry-Stainless Steel

Designed for food preparation areas and hospital applications where the highest levels of hygiene have to be observed. Automatic 'no-touch' hand dryer.

- Cover: Satin polished stainless steel
- Motor: External Rotor Brushless Motor 2700 rpm
- Insulation Earthed Class 1
- 280 x 270 x 148mm (H x W x D)
- Weight: 4.0kg (4.5kg packed)
- Sound level: 65 dB(A) at 1m
- Rated at: 2.0 kW at 240V
- 31 second drying time
- Supply voltage: 220-240V/1/50Hz
- BEAB Approved
- IP24 Rated
- Cable entry bottom right



Stock Ref

20101440



Easy Dry Range

An economical ABS covered automatic dryer, designed for use in applications where good performance linked with price sensitivity is of paramount importance.

- 2500 - 4200rpm induction motor
- Insulation Earthed Class 1
- 225 x 275 x 160mm (H x W x D)
- Weight: ABS Models - 3.3kg (3.65kg packed),
- Sound levels: 54 dB(A) at 1m
- Rated: 1.0kW, 1.25kW or 2kW at 240V
- 30 seconds drying time
- Supply voltage: 220-240V/1/50Hz
- GS Approved
- IP22 Rated
- Cable entry bottom right



Models	RPM	Stock Ref
1.0kW ABS	2500	427935
1.25kW ABS	2500	436297
2kW ABS	2500	497154

Insect Killers & Hand Sanitiser



IK50

- Durable ABS fire proof plastic on side panels
- Large removable collection tray for easy cleaning
- High quality aluminium, easy to clean. Crack, fade, scratch and oil resistant
- Fully protected outer mesh
- Energy efficient UV-A lamp
- Free standing, suspend or hang from wall
- Approved to EN60335-2 59 CE/GS/ROHS/REACH/PAH(TUV)
- Weight: 1.83kg
- Coverage: 50m²
- Watts: 2x 8W
- Includes Type G British 3-pin electrical plug

Model	Stock Ref
IK50	446878
Spare Bulb	446937

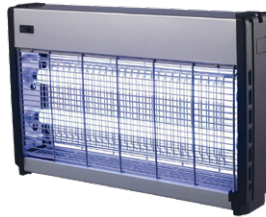

IK80

- Durable ABS fire proof plastic on side panels
- Large removable collection tray for easy cleaning
- High quality aluminium, crack, fade, scratch and oil resistant
- Fully protected outer mesh
- Energy efficient UV-A lamp
- Free standing, suspend or hang from wall
- Approved to EN60335-2 59 CE/GS/ROHS/REACH/PAH(TUV)
- Weight: 2.6kg
- Coverage: 80m²
- Watts: 2x 10W
- Includes Type G British 3-pin electrical plug

Model	Stock Ref
IK80	446879
Spare Bulb	446938



IK150

- Durable ABS fire proof plastic on side panels
- Large removable collection tray for easy cleaning
- High quality aluminium, easy to clean. Crack, fade, scratch and oil resistant
- Fully protected outer mesh
- Energy efficient UV-A lamp
- Free standing, suspend or hang from wall
- Approved to EN60335-2 59 CE/GS/ROHS/REACH/PAH(TUV)
- Weight: 3.60kg
- Coverage: 150m²
- Watts: 2x 20W
- Includes Type G British 3-pin electrical plug

Model	Stock Ref
IK150	446880
Spare Bulb	446939



Touchless Sensor Operated Hand Sanitiser/Soap Dispenser

- Touchless operation to reduce cross contamination and the spread of germs
- Gel hand sanitiser and liquid soap
- Lockable via a key to prevent tampering
- Easy to view window for replenishment
- Bulk fill unit
- Lightweight at only 700g
- 1100ml capacity
- 1ml delivery shot
- Battery operated, 6V (4 x AA batteries)
- 70,000 cycle battery life
- Material: High impact ABS plastic
- Sensor range: 3-10cm

Model	Stock Ref
Hand Sanitiser	495929

Cooling



Vent-Axia offers a range of cooling products for both fixed and portable applications. Products such as Hi-Line Plus are ideal for warehouse or office environments with high interior ceilings. For emergency or occasional use, our portable box fan is ideal.

NEW Stanza 48" Ceiling Sweep Fans

The Stanza fan is a stylish, modern ceiling fan, ideal for homes, offices, stores, shops and many other applications. The precision moulded glass fibre composite blades give increased stability and higher airflow, working to cool the environment in summer months. In winter months, the Stanza can be set to Eco mode, which will gently recirculate heat from the ceiling towards occupants, therefore helping to conserve energy.

Vent-Axia[®]





Hi-Line Plus 35-55" Ceiling Sweep Fans

J:3



NEW Stanza 48" Ceiling Sweep Fans

J:4



Jupiter De-Stratification Unit

J:5



12" Wall Fan

J:6



14" Box Fan

J:6

Hi-Line Plus[®] Ceiling Sweep Fans

- Suitable for winter de-stratification applications or summer cooling
- Three sweep diameters: 900mm, 1200mm, and 1400mm
- Two down rod lengths included
- Easy to install
- Quiet running
- Can be installed for either upward or downward airflow
- Reversible electronic controller available



De-stratification Fans

Hi-Line Plus ceiling fans can be used in offices, stores, shops, foyers, schools, hospitals, kitchens, restaurants and many industrial applications such as warehouses, factories, tanneries and workshops. Hi-Line Plus fans will provide effective and positive air movement to improve the working environment particularly during summer months. In addition, Hi-Line Plus fans can be used during winter months to re-circulate hot air from ceiling areas down to living and working areas thus helping to conserve energy.

An infinitely variable speed controller is available for use with one or a combination of models up to 3 units. Alternatively, Hi-Line Plus fans may be wired directly to a normal On/Off switch. For maximum benefit, good ventilation is vital, we advise that Hi-Line Plus fans are used in conjunction with Vent-Axia T-Series or Standard Range ventilation units.

Hi-Line Plus blades are produced from sheet steel and individually weighed to produce matched sets.

Motor

The motor is totally enclosed, capacitor start and run. Suitable for temperatures up to +40°C. Supply Voltage 220-240V/1/50Hz.

Down Rods

The Hi-Line Plus fans include both a long and short down rod packaged as standard. The total drop length of the short down rod including motor is 360mm. The total drop length of the long down rod including motor is 610mm.

Models

Model	Stock Ref
HL 90	428049
HL 120	428050
HL 140	428051

Ceiling Fan Controller

SAC3 Reversible Controller

The Vent-Axia ceiling fan controller adds extra flexibility to all Hi-Line Plus installations. Fan speeds can be selected to suit varying conditions. This is of particular benefit where mounting height is low. The controller is designed to be used with a single fan or up to 3 Hi-Line fans.

The controller is infinitely variable, has solid state components, an insulated spindle, white cover plate and can be flush or surface mounted. Suitable for commercial environments.

Hi-Line Plus fans should be used only with a Vent-Axia ceiling fan controller or an On/Off switch. Supply Voltage 220-240V/1/50Hz.

Model	Stock Ref
Controller	499301

For completely silent running we recommend the use of a 5 step transformer. Suitable for up to 9 ceiling sweep fans.

Model	Stock Ref
5 Step Transformer	10314103

Performance

Model	Sweep Dia. mm	Colour	Air Displacement m ³ /h	Max. Watts	Amps @240V	RPM
HL 90	900	White	8100	41	0.176	335
HL 120	1200	White	12600	52	0.235	315
HL 140	1400	White	15000	65	0.285	295

Weight approximately 7kg.

NEW Stanza 48" Ceiling Sweep Fans

- Satin white indoor ceiling fan available with or without dimmable LED light
- Three speed settings allowing for use in summer or winter
- Delivered with three-speed long distance remote control
- 48" precision moulded blades for higher airflow
- Individually balance tested and quality checked for trouble free operation
- True-spin Technology™ for enhanced efficiency and performance
- Four year warranty



Overview

The Stanza fan is a stylish, modern ceiling fan, ideal for homes, offices, stores, shops and many other applications*. The precision moulded glass fibre composite blades give increased stability and higher airflow, working to cool the environment in summer months. In winter months, the Stanza can be set to Eco mode, which will gently recirculate heat from the ceiling towards occupants, therefore helping to conserve energy.

There are three settable speeds on the Stanza fan, which can be set with the remote control that is included. The ceiling fan can displace air at either 5,700, 8640 or 11,700 m³/h, depending on the speed that has been selected.

The motor in the Stanza fan uses the latest developments in ceiling fan motor engineering. It means that the fan offers enhanced efficiency and performance. The motor, in conjunction with the moulded blades, provides more air movement per. watt of power, therefore using less energy to provide better air circulation.

Each fan is individually tested and quality checked to ensure trouble free operation. The Stanza fan also has a four year warranty for peace of mind.

LED Light

The Stanza LED model uses a 20 watt LED acrylic light to add dual functionality to the fan. The light can be set at 25%, 50%, 75% or 100% to suit the needs of the occupant, simply by changing the setting on the remote.

Ceiling Fan Controller

The Stanza ceiling fan comes delivered with a three speed remote control. You are able to change the fan speed using Eco, Medium or High buttons accordingly. It is recommended that Eco mode is used in winter to re-circulate warm air at low speeds.

The remote uses radio frequency, so that you can operate the fan at long distances.

There is a four step dimmable light function, allowing you to change the brightness of the light to either 100%, 75%, 50% or 25%. The remote also has quick connect terminals.

Performance

Stock Ref	Sweep Dia. mm	Colour	Air Displacement m ³ /h	Max. Watts	RPM
STA1203WH-VA	1220	Satin	5700/8640	55	190/150
STA1203WHLED-VA		White	/11700		/105

Dimensions

Stock Ref	Width (mm)	Height (mm)	Weight
STA1203WH-VA	1220	349	7 kg
STA1203WHLED-VA	1220	370	7 kg

Models

Stanza 48" Ceiling Fan with Wireless Remote

Stock Ref

STA1203WH-VA

Stanza 48" Ceiling Fan with LED Light & Wireless Remote

Stock Ref

STA1203WHLED-VA

* Must be mounted above 2.3m

Jupiter De-Stratification Unit

- Available in two sizes
- Speed controllable
- High velocity fans
- Supplied with a grey coated finish - other colours available to special order
- Available with built-in thermostat



Air Movement Fans

The Vent-Axia Jupiter range of de-stratification units is based on direct drive axial fans, housed in a neat and sturdy casing complete with eyebolts for suspension from chains or steel wires. Ideal for applications where the proposed mounting height requires higher velocity fans or where open bladed ceiling fans are considered unsuitable. Jupiter fans can be used in stores, warehouses, factories, workshops, as well as many other industrial applications. The unit provides effective and positive air movement to improve the working environment, particularly during summer months. In addition Jupiter fans can be used during the winter to re-circulate hot air from ceilings and roofs down to living and working areas.

Electrical

Supply voltage 220-240V/1/50Hz. Direct drive axials with speed controllable motors. The motor hub and impeller are statically and dynamically balanced for smooth operation and optimum performance. Class F insulation, suitable for operating in atmospheres of up to 95% RH and ambient temperature of up to +60°C.

General Installation

For cooling effect, circulation of air is required in any given area. As a guide, mount Jupiter fans 4.5-6m apart, in tropical climates 3m apart. Fans should be mounted so that they do not interfere with lighting installations in any way. Mount fans away from walls or pillars where possible to avoid obstruction of airflow.

Heat Saving

Heat savings are largely dependent on the difference between the roof level and the working level temperatures, the ventilation rate and the geographical position.

Models

Model	Stock Ref
NJUP315	457485
NJUP400	457487
NJUP400CTS	457488

Accessories

Model	Stock Ref
Speed Controller	RTRE20
ThermoSwitch	563502
Suspension Pack	457490

Dimensions (mm)

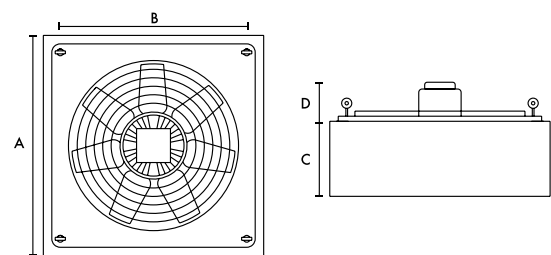

Size	A	B	C	D	Weight
315	500	380	200	84	11 kg
400	620	490	200	93	16 kg

Performance

Models	Duty		Speed		220/240V/50Hz/1Ph			Max Mounting Height	
	CFM	m ³ /s	RPM	dB(A) @3M	kW	FLC	SC	Feet	Metres
NJUP315	1290	0.610	1380	45	0.15	0.70	2.50	44	13.4
NJUP400/CTS	3000	1.415	1320	51	0.35	1.60	5.50	72	22.0

Vent-Axia Cooling



12" Wall Fan

The 12" Wall Fan has a quiet operating motor for minimal disturbance. The 3-speed options and free neck allow the fan to move back and forth in a regular rhythm. The fan has an 8 hour On/Off timer which can be set via remote controller. The fan comes with a double insulated cable and Type G British 3-pin electrical plug making it easy to install without wiring it into the wall.



Stock Ref
427583



14" Box Fan

The 14" Box Fan is a portable cooling fan with a quiet operating motor ideal for office spaces when additional cooling is needed. With its 3-speed options and 360° louver system, cool air can be distributed in any preferred direction. The in-built double insulated cable and Type G British 3-pin electrical plug, makes it safe and easy to plug and use where needed.



Stock Ref
427584

Electric Heating



Vent-Axia heating is ideal for residential or commercial applications. So whether it's a bedroom or hallway, office or shop, we can provide the solution.

The simplicity of installing electric heating, particularly in high rise apartments means it is the natural choice for your project.

Comfort heating products with innovative zone control features provide energy savings for the occupier without compromising comfort in the home, coupled with low capital outlay they offer a cost effective solution for installer and occupier.

Vent-Axia





Heated Towel Rails

K:3-K:4



Radiant Heaters

K:5-K:6



Lot 20 Panel Heater

K:7



Warm Air Curtains

K:8

Heated Towel Rails

- New and improved IP55 rated
- Plug kit can be handed left or right
- Five year leakage warranty
- One year manufacturer's warranty
- Heating element included
- Stylish designs
- Steel construction with high quality white and chrome finishes
- Production is carried out using latest technology resulting in absolute consistency in quality
- Complete fitting set supplied



Range Options

Vent-Axia Heated Towel Rails quickly warm and dry towels. Their presence on the wall also adds to the overall style, temperature and comfort of the room.

This comprehensive range of white and chrome towel rails offers 9 different models across the flat, curved and designer ranges. The range offers sizes from 500 x 600mm to 500 x 1500mm available in four heat outputs of 100, 150, 250 and 400W matched to the size of the rail.

Advantages of Towel Rails

Adequately heating your bathroom using a Vent-Axia towel rail not only leaves your towels warm and dry, but helps regulate temperature to the rest of the room decreasing the chances of mould and condensation.

Product Selection

Sizing the correct towel rail can be made easy by using our online heating tool available on the website www.vent-axia.com/heating-guide

Style and Comfort

With the Vent-Axia range of towel rails you will find a towel rail to suite all applications and sizes. Every towel rail uses thermally regulated heating elements and a mixture of high inertia fluid to order to maintain even heat distribution around the entire rail.

Controller

The range is complemented by an advanced controller available in white and chrome giving you control of five heat outputs. The controller also offers an eco mode ideal for use when drying your towels to ensure minimal energy use. This feature turns on the rail on full power for 30 minutes then reduces the output to the user setting for a further 90 minutes before turning the towel rail off.



- IPX4 rated
- White or chrome finish
- Five power settings
- Eco timed function
- Two year warranty

Model	Stock Ref
VATRCW White	447864
VATRCC Chrome	447865

Specification



Stock Ref	Model	Description	Finish	Dimensions mm		Output
				W	H	W
476254	VATR150F	Flat	Chrome	400	700	150
476255	VATR250F-W		White	500	1100	250
476256	VATR250F		Chrome	500	1100	250
476257	VATR400F		Chrome	500	1500	400



Stock Ref	Model	Description	Finish	Dimensions mm		Output
				W	H	W
476258	VATR250C	Curved	Chrome	500	1100	250
476259	VATR400C		Chrome	500	1500	400



Stock Ref	Model	Description	Finish	Dimensions mm		Output
				W	H	W
476260	VATR250-FR	Flat Railed	Chrome	500	1000	250
476261	VATR150-FR		Chrome	400	700	150



Stock Ref	Model	Description	Finish	Dimensions mm		Output
				W	H	W
476262	Varma	Designer	Chrome	500	1200	250



Stock Ref	Model	Description	Finish	Dimensions mm		Output
				W	H	W
476263	Atacama	Designer	Chrome	500	1200	250

Radiant Heaters

- Economical and easy to install
- Silent in operation
- No yearly maintenance cost
- Instant heat from switch on
- Precision heating directed where needed

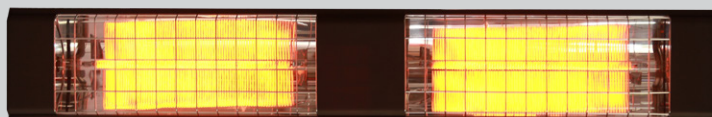
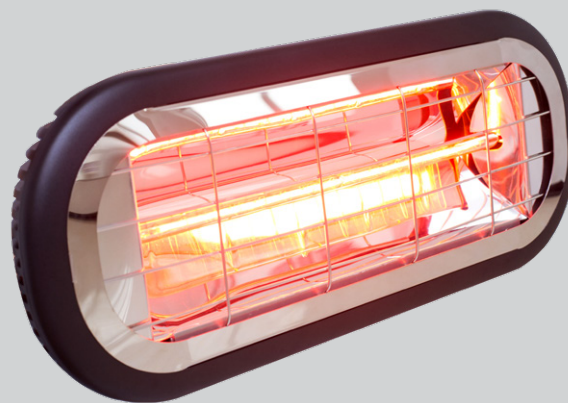

Profile

The Vent-Axia radiant heating product range gives the flexibility to deal with large and small unheated spaces which would be uneconomical to heat using traditional space heating.

Areas such as bars, restaurants, terraces, delivery areas, warehouses and churches are some examples where the radiant heating products will provide an economical heating solution.

Radiant heat and its advantages

The heat felt from the sun is called radiant heat and is part of the electromagnetic spectrum called infrared. Ultra violet and visible light also belong to the same family.

Visible light is the easiest part of this spectrum to understand, light travels in a straight line from the source, is unaffected by air and is invisible until it hits a surface. Shadows are a good example of this and are the absence of light.

Infrared rays behave in the same way, they cannot be seen but can be felt as warmth. A good example of this is the effect created when you move from the shade into the sun, although the temperature is the same, the perceived temperature when in direct sunlight is much higher. This phenomenon makes sunbathing possible during winter holidays. There are three categories of infrared; short wave (IR A), medium wave (IR B) and long wave (IR C), the shorter the wave length the easier it travels through the air.

The advantage when using short wave infrared heating is that the rays cut through the air and are not affected by air movement and only transmits its energy when it collides with a solid object. The rays also travel in a straight line so can be directed where you need it, ideal in locations which feature high ceilings, have high air change rates or are outside.

Convection Heating and Radiant Heating Comparison

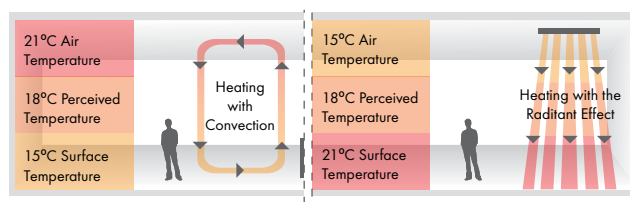

Wave Infrared comparison

	Short Wave Infrared	Medium Wave Infrared	Long Wave Infrared
Typical source	IR Halogen Lamp	Quartz Heat Source	Resistance
Materials	Tungsten Filament welded in a quartz tube	Filament in compound of Fe-Cr-Al in a quartz tube	Filament in compound of Fe-Cr-Al in a steel tube
Radiant efficiency	92%	60%	40%
Switch on/off times	1 second	30 second	5 minutes

Models

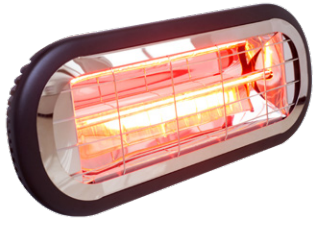

Model
Sunburst 2kW

Stock Ref
SUNB2000BL-VA

Dimensions (mm)

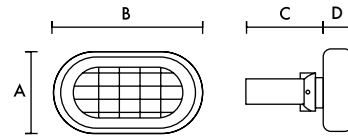

Stock Ref	A	B	C	D
SUNB2000BL-VA	190	460	113	107



Model
Sunburst 3kW

Stock Ref
SUNB3000BL-VA

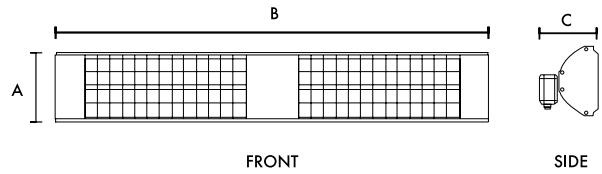

Stock Ref	A	B	C
SUNB3000BL-VA	150	935	85.5

Technical Details

Stock Ref	Model	Weight kg	Voltage rating	Luminous spectrum	Accessories	Output W	Amps	Heating range m ²	Lamp Type	Element Life Span
SUNB2000BL-VA	Sunburst 2kW	2.6	220-240V 50Hz	IR-A	Wall bracket	2000	9	10-12	Low glare halogen lamp	5000 hrs
SUNB3000BL-VA	Sunburst 3kW	4.6	220-240V 50Hz	IR-A	Wall bracket	3000	14	18-36	Long life carbon fibre lamp	10000 hrs

Lot 20 Panel Heaters

- Complies with Lot 20 ERP directive
- Silent operation
- Energy saving 'open window' detection
- Slim line design with 3 sizes available
- Electronic thermostatic control accurate +/- 0.2°C
- Easy to use top mounted customised user-defined LCD display controls
- 7 day electronic programmable controls with backlit display
- 12 pre-set heating profiles
- Splash proof to IP24 for bathrooms or wet areas
- Overheat thermal cut-out
- Supplied with wall fittings
- Suitable for domestic or commercial application
- 2 year replacement warranty



Comfort Heating

Lot 20 Panel Heaters are direct acting heaters, used to heat up a space quickly with 100% efficiency.

Vent-Axia's Panel Heaters offer a range of heat outputs from 1kW to 2kW and every model comes with electronic thermostatic control and 12 pre-set heating programmes. Vent-Axia Panel Heaters look as good as they perform. Stylish and slim, they occupy minimal wall space and are finished in an attractive gloss white finish.

Vent-Axia Panel Heaters are wall mounted and connected to the permanent electrical supply via a fused connection switched outlet. Vent-Axia Panel Heaters are supplied with mounting brackets, 1.5m of flex and come fitted with an easy to use LCD display screen.

Models

Model	Stock Ref
VAPH1000	495792
VAPH1500	495793
VAPH2000	495794

Adjustable Electronic Thermostat

All Vent-Axia Panel Heaters have a built-in adjustable thermostat offering a full temperature range between 5-30°C, including a 5°C frost protection setting.

For maximum safety there is also a child safety lock and thermal cut-out on all models to prevent overheating should the outlet grille be accidentally covered.



Specification

Model	Power		Heating		Voltage	Approval	Product dimensions mm			Packaged dimensions mm			Product Weight kg	Gross Weight kg
	W	Colour	Setting W	Area m ²			H	W	D	H	W	D		
VAPH1000	1000	White	1000	10-13	230-240V 50Hz	CE, EMC, LVD, RoHS, ERP	440	455	125	505	520	155	4	5.1
VAPH1500	1500		1500	15-18			440	615	125	505	680	155	5.1	6.3
VAPH2000	2000		2000	20-23			440	775	125	505	840	155	6.55	7.88

Warm Air Curtains

- Integral switching for faster installation
- Three heat settings and fan only mode
- Models to suit single and double doorways
- Suitable for use as a high level fan heater

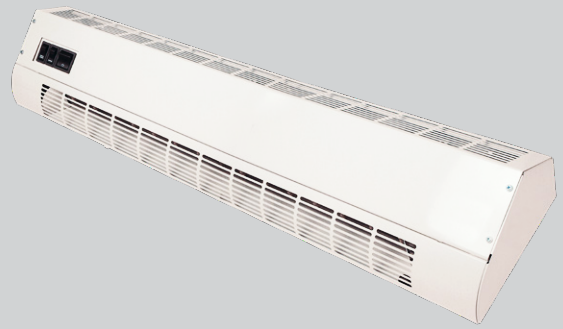

Vent-Axia Warmair Curtains provide a heated downflow of warm air in doorways of commercial premises such as shops, offices and schools.

The robust outer case is made from painted steel with an off white epoxy finish. Accommodating varying door widths is easily achieved by installing Warmair units 'side by side'.

Vent-Axia Warmair Curtains are supplied with 0.75m of 3 core cable, and mounting brackets. The mounting brackets are only available with Warmair 3 and Warmair 4.5, but not with the Warmair 6.

Three Warmair models are available offering heat outputs plus fan only setting:

- Warmair 3 - 3 kW, 2 kW, 1 kW
- Warmair 4.5 - 4.5 kW, 3 kW, 1.5 kW
- Warmair 6 - 6kW, 3 kW

Models



Warm Air Curtains

Model	Stock Ref
Warmair 3	456343
Warmair 4.5	456344
Warmair 6	456345

Remote Switch

Remote Switch unit to control Warmair units. Switch allows for fan only & three heat settings.

Model	Stock Ref
VARSU	436494

Specification

Model	Rating	Dimensions mm			Weight
	kW	W	H	D	kg
Warmair 3	3.0	650	103	210	6.1
Warmair 4.5	4.5	650	103	210	6.5
Warmair 6	6.0	900	103	210	8.7

220-240V-50Hz. BEAB Approved.

Accessories & Controllers



For ventilation systems to be truly efficient it is important for them to operate only when needed. Our range of Sentinel demand ventilation systems along with our controls and sensors help respond to the exact ventilation requirements of a room at any one time. Providing airflow only when it is required and at the level that it is required ensures that only the energy that is needed is used; no more, no less.

Approved Document L recognises the value that controls can offer and you will find Vent-Axia offers a range of solutions to ensure that you can maximise the benefit of automation wherever you chose to use it.

Vent-Axia

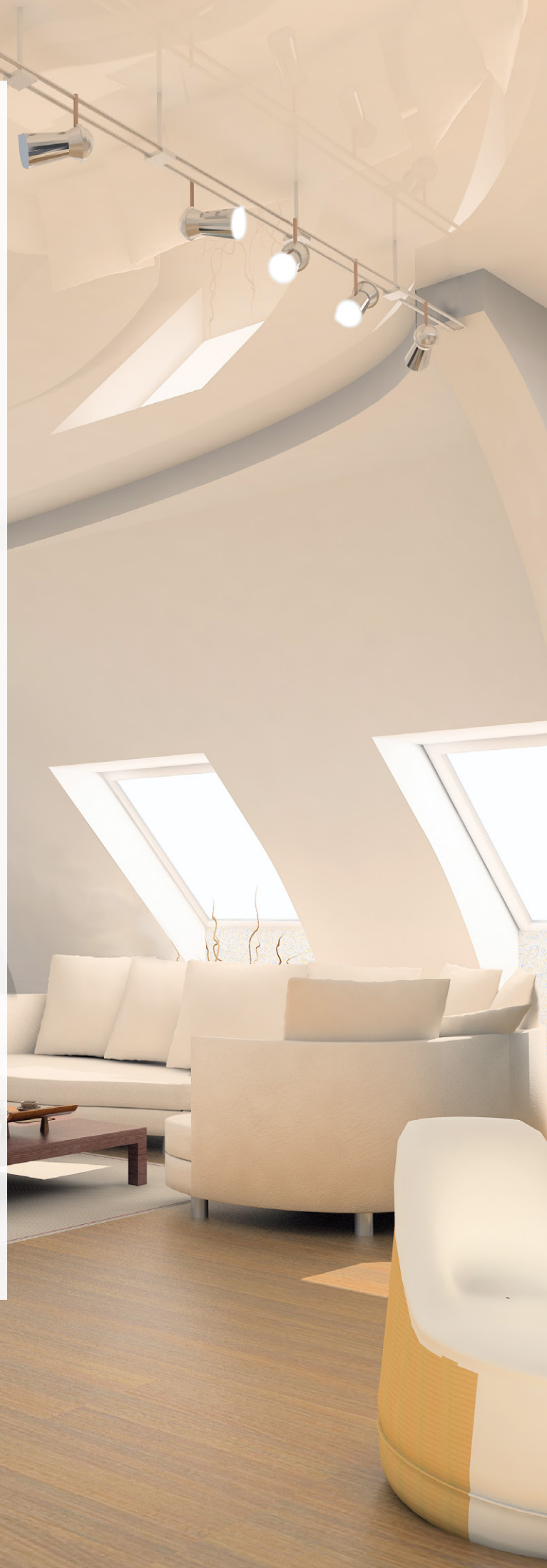



Controllers and Sensors

L:3-L:10



Ventilation Accessories

L:11-L:18

Controllers & Sensors



Ecotronic Controller Surface

Mounting

An electronic controller for use with all Traditional T-Series and Standard Range models to give extract/intake and speed variation. For groups of units of any one size up to a total of 400 Watts. Do not mix T-Series with Standard Range. Where a controller is used with T-Series, 5-core flexible cable is required.

- 'E' running position for optimum efficiency.
- Finger-tip sliders.
- Infinitely variable speed control.
- Double pole On/Off switching.
- Extract/intake airflow direction.
- Neon indicator.
- Sensor mode for use with suitable electromechanical switches, eg. ThermoSwitch, HumidiSwitch to give automatic fan operation.
- Adjustable minimum speed setting.
- Knockouts for recessed wiring.
- Ambient operating temperature range 0°C to +40°C.
- Dimensions: 86 x 156 x 53mm (H x W x D).
- Supply voltage 220-240V/1/50Hz.
- Maximum load: Ecotronic - 400 Watts.
- Designed to meet IP20.
- BEAB approved.

Stock Ref
W362320

Flush Fitting Box

Stock Ref
400144

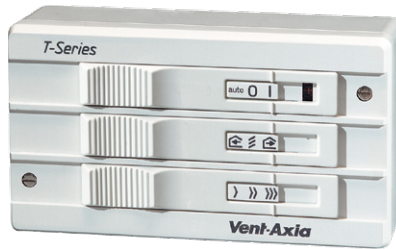

T-Series® Controller Surface

Mounting

A single unit controller for use with all Traditional T-Series ventilating units. With knockouts for recessed wiring. Where a controller is used with T-Series, 5-core flexible cable is required.

- 3-speed operation. High, medium or low.
- Finger-tip sliders.
- Double pole On/Off switching.
- Extract/intake airflow direction.
- Sensor mode for use with suitable electromechanical switches, eg. ThermoSwitch, HumidiSwitch to give automatic fan operation.
- Unique shutter open/ fan Off setting.
- Neon indicator.
- Knockouts for recessed wiring.
- Ambient operating temperature range 0°C to +40°C.
- Dimensions: 86 x 156 x 53mm (H x W x D).
- Supply voltage 220-240V/1/50Hz.
- Designed to meet IP20.
- BEAB approved.

Stock Ref
W361119

Flush Fitting Box

Stock Ref
400144



TimeSpan® Controller

Adjustable timer with overrun facility for fans ventilating WCs and other small rooms.

For use with any Vent-Axia fan within maximum rating below. The fan is switched On with the light and keeps running for a pre-set period after the light is switched Off.

- Fits to any single gang box.
- Adjustable time delay 5-25 minutes.
- Ambient operating temperature range 0°C to + 40°C.
- Maximum load 250W inductive.
- BEAB approved.
- Dimensions: 87 x 87 x 33mm (H x W x D).
- Supply voltage 220-240V/1/50Hz.
- Will fit single gang box for surface mounting.

Stock Ref
563519

Surface Mounting Box

A surface mounting back box is available.

Stock Ref
410020

Registered design numbers: 1 030 207 Surface Mounting Controller, 1 030 208 Flush Fitting Controller. Patented Remote Speed Control Circuit. European Patent number EP 0180311.



Air Quality Sensor

Automatically reacts to the depletion of air quality, sensing unpleasant smells and toilet odours to regulate mechanically ventilated areas such as cinemas, pubs, clubs, restaurants, kitchens, toilets and conference rooms. This is not a CO₂ sensor.

The sensor switches the fan On when the air quality declines below an adjustable preset level. This is registered by the ceramic sensing head which is self-cleaning, a process which occurs every time the unit is triggered. When the atmosphere has returned to normal, the fan will continue to run for a pre-set period (adjustable between 1-25 minutes) and then switch Off.

The air quality sensor should not be used for the detection of combustible gases and is not designed for use as a smoke detector in an alarm system.

For use with various Vent-Axia fans within maximum rating below.

The Air Quality Sensor is also able to switch between trickle and boost speed on the appropriate ventilation units.

- Ambient operating temperature range 0°C to +50°C.
- Dimensions: 87 x 157 x 47mm (H x W x D).
- Maximum switched load: 2A inductive at 240V.
- Sensor consumption: 25mA at 240V.
- Supply voltage 240V/1/50Hz.

Stock Ref
563506



Electronic 1.5A Controller

Surface mounted, providing infinitely variable speed control and features an On/Off/sensor slider with neon indicator. There is an adjustable minimum speed setting. The controller is radio suppressed to BS EN 55014 and electrical connections for use with suitable external sensors are provided.

86 x 156 x 53mm (H x W x D).

Hole for wall box:
80x150x150mm (H x W x D).

Stock Ref
W300310

For flush fitting a metal wall box accessory is available.

Flush fitting box
Stock Ref
400144



HR500 Controller

Suitable for use with HR500 MVHR units. Surface mounting. On/Off remote sensor mode. Heat exchange, single fan extract or twin fan extract modes. Infinitely variable speed. Minimum speed setting.

Stock Ref
W14301010

Controllers & Sensors



Ambient Response Humidity Sensor

A self programming electronic On/Off wall mounted humidity sensor which reacts to any rapid increase in humidity and temperature by switching a Vent-Axia fan 'On' for rapid removal of moisture laden air in domestic bathrooms and kitchens. Can be wired into controller 'Auto' mode connections. Night time relative humidity increment setback feature suppresses nuisance tripping when the humidity level gradually rises as the temperature falls.

- Pullcord override and neon indicator.
- Changeover relay switch.
- Operating range: 30%-90%RH.
- Ambient operating temperature +5°C to +40°C.
- Dimensions: 87 x 87 x 33mm (H x W x D).
- Will fit single gang box for surface mounting.

Stock Ref
563550 240VAC 50Hz

European Patent No: 2298057

Surface Mounting Box

A surface mounting back box is available.

Stock Ref
410020



Ambient Response SELV 12 Humidity Sensor

12V Safety Extra Low Voltage version for use with VA100 SELV, Solo SELV, LuminAir SELV and HR100 SELV range.

The latest self programming electronic On/Off wall mounted humidity sensor which reacts to any rapid increase in humidity and temperature by switching a Vent-Axia fan 'On' for rapid removal of moisture laden air in domestic bathrooms and kitchens. Can be wired into controller 'Auto' mode connections. Night time relative humidity increment setback feature suppresses nuisance tripping when the humidity level gradually rises as the temperature falls.

- Pullcord override and neon indicator.
- Changeover relay switch.
- Operating range: 30%-90%RH.
- Ambient operating temperature +5°C to +40°C.
- Dimensions: 87 x 87 x 33mm (H x W x D).
- Will fit single gang box for surface mounting.

Stock Ref
563551 12VAC 50Hz

Surface Mounting Box

A surface mounting back box is available.

Stock Ref
410020



Lo-Carbon Ambient Response Humidity Sensor

Designed specifically for the Lo-Carbon product range. This self programming electronic On/Off wall mounted humidity sensor reacts to any rapid increase in humidity and temperature by switching a Vent-Axia fan 'On' for rapid removal of moisture laden air in domestic bathrooms and kitchens. Night time relative humidity increment setback feature suppresses nuisance tripping when the humidity level gradually rises as the temperature falls.

- Pullcord override and neon indicator.
- Changeover relay switch.
- Operating range: 30%-90%RH.
- Ambient operating temperature +5°C to +40°C.
- Dimensions: 87 x 87 x 33mm (H x W x D).
- Will fit single gang box for surface mounting.

Stock Ref
563552 12VDC

Surface Mounting Box

A surface mounting back box is available.

Stock Ref
410020

All of these Sensors can be wired for either On/Off or Trickle/Boost operation.



Ecotronic Humidity Sensor Surface Mounting

An adjustable set point, solid state On/Off sensor. A pullcord provides manual override, indicated by lamp. Adjustable from 65 to 90% relative humidity. Can be wired into controller 'Auto' mode connections. Incorporates changeover switch to select low/high speed.

- Setting range 65% - 90%RH.
- Maximum switching load 1 Amp inductive.
- Pullcord override indicated by lamp.
- Ambient operating temperature 0°C to +40°C.
- Dimensions: 87 x 87 x 33mm. (H x W x D).
- Supply voltage 220-240V/1/50Hz.

Stock Ref
563532

Surface Mounting Box

A surface mounting back box is available.

Stock Ref
410020



Ecotronic® SELV 12 Humidity Sensor

12V Safety Extra Low Voltage version for use with VA100 SELV, Solo SELV, and LuminAir SELV range. Incorporates changeover switch to select low/high speed.

Although suitable for siting within reach of a shower or bath we recommend this model is located out of the spray zone of a bath or shower.

- Setting range 65% - 90%RH.
- Maximum switching load 5.6A @ 12V AC.
- Pullcord override indicated by lamp.
- Ambient operating temperature 0°C to +40°C.
- Dimensions: 87 x 87 x 33mm (H x W x D).
- Supply voltage 12V AC.

Stock Ref
563531

Surface Mounting Box

A surface mounting back box is available.

Stock Ref
410020



Vent-Axia HumidiSwitch

Operates Vent-Axia ventilating units on either a rise or a fall in humidity to control the damaging effects of condensation.

- Concealed adjustment.
- Setting range 20% to 80% RH.
- Ambient operating temperature 0°C to +50°C.
- Dimensions: 82 x 132 x 40mm (H x W x D).
- Rating 2A (1A inductive).
- Switching range 120-240V.
- Designed for use with controllers with 'Auto' mode facility.
- Single pole changeover contacts.

Stock Ref
563501

The Ecotronic and Ecotronic SELV 12 Sensor can be wired for either On/Off or Trickle/Boost operation.

Controllers & Sensors



7 Day TimeSwitch

For applications where regular switching is required at fixed periods or at different times on different days of the week, eg: offices, shops, pubs and restaurants.

The 7-day TimeSwitch gives twelve On or Off positions per day and can be set for 7 days. The cycle will repeat until changed.

- Analogue clock display and integral time switches for ease of setting.
- Manual override.
- Removable clear plastic cover protects TimeSwitch face.
- Volt free changeover contacts.
- Time base: 7 days.
- Shortest switching time: 2 hours.
- Maximum load: 16amp resistive (8amp inductive).
- Ambient operating temperature range -20°C to +85°C.
- Dimensions: 104 x 74 x 52mm (H x W x D).
- Supply voltage 220-240V/1/50Hz.

Stock Ref
563515



Vent-Axia ThermoSwitch

Automatically switches On fans on either a rise or fall in air temperature. The ThermoSwitch can be used with all Vent-Axia fans (via switch gear if appropriate) for the removal of warm air from buildings. It can also be used to switch On Hi-Line ceiling fans for summer cooling and to move high level warm air down to the working level during winter.

- Setting range: +6°C to +30°C.
- Two internal range limit/locking rings are included to allow setting within a limited temperature range or locking at a fixed t/o point.
- IP20 rated.
- Sealed sensing mechanism.
- Snap-action, single pole, changeover contacts.
- Mounting direct on surface only.
- Electrical connection to screw type terminals with rear or side cable entry.
- Dimensions: 80 x 104 x 36mm (H x W x D).
- Contact rating: 1.5 amp (inductive).
- 16 amps (resistive).
- Maximum voltage 250V.

Stock Ref
563502



Guardian Personnel Detector (PIR Sensor)

Suitable for controlling a range of Vent-Axia fans. Continuously monitors an area and activates when a moving body is detected.

- Supplied complete with wall mounting bracket.
- Adjustable timer overrun (5 seconds to 20 minutes).
- Supplied with lens to provide 15m (max) range, 200° detection area.
- Designed to meet IP55.
- Ambient operating temperature range -20°C to +50°C.
- Maximum load: 10 amp resistive (5 amp inductive).
- Suitable for use with fluorescent lighting up to 500W.
- Internal/External use.
- Supply voltage 220-240V/1/50Hz.

Stock Ref
563548

7 day Time Switch & ThermoSwitch can be wired for either On/Off or Trickle/Boost operation.



Vent-Axia Visionex PIR

A wall or ceiling mounted movement detector for use with any domestic Vent-Axia mains voltage product. Also suitable for use with Vent-Axia T-Series controllers on 'Auto' setting and ITC controllers on sensor mode. Visionex PIR can be wired for either On/Off or Trickle/Boost operation.

- Fits any UK single gang mounting box.
- Adjustable timer overrun (5-25 minutes).
- Range of detection up to 10 metres.
- Designed to meet IP43.
- Ambient operating temperature range 0°C to +50°C.
- Maximum load: 2.5 amps/600W inductive. Not suitable for use with lighting.
- Internal use only.
- No switched live required for internal rooms and WCs.
- Double insulated.
- Volt-free contacts.
- Supply voltage 220-240V/1/50Hz.

Stock Ref
459623

Surface Mounting Box

A surface mounting back box is available.

Stock Ref
410020



Vent-Axia Visionex SELV 12 PIR

A wall or ceiling mounted movement detector for use with any domestic Vent-Axia SELV 12 product.

- Fits any UK single gang mounting box.
- Adjustable timer overrun (5-25 minutes).
- Range of detection up to 10 metres.
- Designed to meet IP43.
- Ambient operating temperature range 0°C to +50°C.
- Maximum load: 5.6 amps inductive @ 12V.
- Internal use only.
- No switched live required for internal rooms and WCs.
- Class III product.
- Volt-free contacts.
- Supply voltage 12V/1/50Hz.

Stock Ref
459624

Surface Mounting Box

A surface mounting back box is available.

Stock Ref
410020



3 Pole Isolator

Isolates Live, Neutral and Switched Live for integral timer fans. 6 amp, 3 pole isolator complying to the 3mm contact separation requirement for routine maintenance repair.

Stock Ref
563518

Surface Mounting Box

A surface mounting back box is available.

Stock Ref
410020



5 Step Auto Controller

Used in conjunction with speed controllable fans to provide 5 stepped speed without electronic motor 'hum'. Several fans can be connected to one transformer provided their combined load does not exceed the controller rating.

Single phase: 3.5, 6.0 and 7.5 amp. Rotary switch giving On/Off and five speeds. Output voltages at 240V/1PH/50Hz 0, 90, 115, 140, 175, 240 volts. Neon indicator. Enclosures are protected to IP54.

Dimensions	Stock Ref
230 x 168 x 118	10314103
230 x 168 x 118	10314105
284 x 240 x 132	10314107

Additional ratings and three phase units are available, please enquire.

Controllers & Sensors



Remote Delay Timer

A remote delay timer for use with all domestic products gives the option of offering a 2 minute delay before the fan starts. Once the fan has started the overrun timer is adjustable between 5-25 minutes.

Stock Ref
457986

Surface Mounting Box

A surface mounting back box is available.

Stock Ref
410020



Isolator Relay Controller

Allows fan unit to be isolated from other mains circuit when used with TIM2, Trickle/boost switch or light switch control.

Stock Ref
442030

Surface Mounting Box

A surface mounting back box is available.

Stock Ref
410020



150VA Transformer

Surface Mounting Transformer with six voltage selections for trickle settings to match dwelling volume. Provides Boost/Trickle ventilation when used with humidity sensors or a manual switch.

95 x 225 x 75mm (H x W x D).

Stock Ref
563538



2-Way Switch and Neons

A double gang switch to boost from high to low speeds on all heat recovery systems, incorporating neon lights to indicate speed settings. Suitable changeover relay required. 85 x 145 x 10mm (H x W x D).

Stock Ref
459746



3 Speed Controller

A three position rotary control which enables the unit to be manually switched from permanent trickle ventilation to either medium or boost speed.

85 x 85 x 25mm (H x W x D).

85 x 85 x 37mm (H x W x D): with rotary switch.

Stock Ref
563533



TIM2 Overrun Timer

The TIM2 is a remote mounting electronic overrun timer with a relay output. 2 Amp indication load maximum. Adjustable overrun 2-30 mins. Ideal for where fans are to be controlled in conjunction with a lighting circuit or activated by remote sensors.

76 x 76 x 41mm. (H x W x D).

Stock Ref
370346



Normal Boost Switch

A single gang switch to boost from high to low speeds on all heat recovery systems.
85 x 85 x 10mm (H x W x D).

Stock Ref
455213



LED Indicator

Compatible with the Sentinel Kinetic range, the LED indicator illuminates when the MVHR unit requires a filter check or if the unit has a fault. Supplied with 15 metres of cable.
85 x 85 x 10mm (H x W x D).

Stock Ref
448356



Normal Boost Purge Switch

A single gang switch to operate between normal, boost and purge speeds.
85 x 85 x 10mm (H x W x D).

Stock Ref
5108454



Momentary Push Switch

Compatible with the Sentinel Kinetic range, the momentary switch boosts the unit for 30 minutes.
85 x 85 x 10mm (H x W x D).

Stock Ref
448929



Summer Mode Switch

Suitable for Integra, HR200V and HR300RW6, the Summer Mode Switch isolates the intake fan to give an Extract-Only mode.

Stock Ref
409999



Normal/Boost Switch - Stainless Steel

A single gang switch to operate normal/boost functions on MVHR systems. Brushed stainless steel finish.
90 x 90 x 18 (H x W x D).

Stock Ref
437320



Normal/Boost Switch with Light Indicator

A single gang switch with LED illumination when in the Boost condition.
85 x 85 x 10mm (H x W x D).

Stock Ref
449060

Ventilation Accessories



Fixing Plates

A single plate available in 300mm and 450mm square modular sizes for permanent fixing on walls or for use with other modular components.

Manufactured in high impact recyclable thermoplastic.

Unit Size	Stock Ref
6"	561136
7"	561137
9"	561139
12"	561142

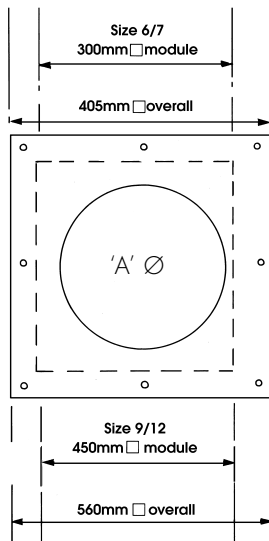

Vent-Axia fixing plate

Unit size	'A' Ø	Module Size
6"	184mm	300mm □
7"	222mm	300mm □
9"	260mm	450mm □
12"	337mm	450mm □



T-Series Adaptor Kits

Used for T-Series Window models in secondary double glazing, Roof models in secondary double glazing in exposed areas, Roof models through roofs and Darkroom models installed through either roof or walls. Adaptor kits allow units to be installed on two surfaces.

T-Series Adaptor kits consist of two Mounting plates with weather-tight seals and a set of fixing screws.

Unit Size	Stock Ref
6"	W561031
7"	W561032
9"	W561033
12"	W561034

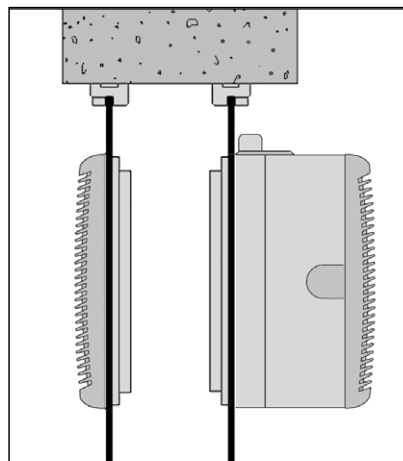

T-Series Extended Fixing Rod Sets

For use with T-Series Window and Roof models fitted through walls. Consists of a set of rods which are cut to suit the wall thickness.

Maximum thickness of wall 370mm.

Rod thread 3.5mm.

Unit Size	Stock Ref
6", 7" & 9"	568104
12"	568106

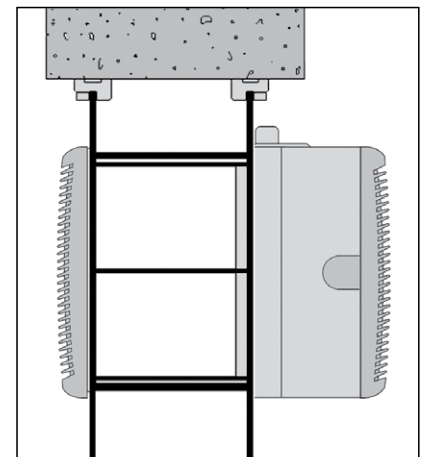



Wall Liner Section

Designed for T-Series units installed in walls thicker than 315mm, each liner section provides a maximum extension of 150mm. Wall liner section can also form a frame for Panel models in walls.

T-Series Wall Liners

Unit Size	Stock Ref
6"	460094
7"	460095
9"	460096
12"	460086

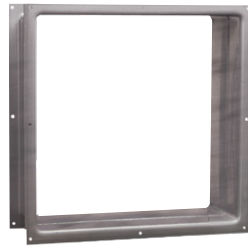

Mounting Boxes

A flanged sleeve in 300mm and 450mm square modular sizes used as an interconnecting sleeve between other modular accessories.

Mounting boxes will accept the depth of a unit and can be mounted in conjunction with a Fixing plate and Eggcrate grille for ventilation through ceilings.

Duct length 200mm.

Unit Size	Stock Ref
6"/7"	560236
9"/12"	560239

Unit Size	Mounting box modular size
6"/7"	300mm □
9"/12"	450mm □

Joining Bolt Set

Set of 8 nuts, bolts and washers.

Stock Ref
563000

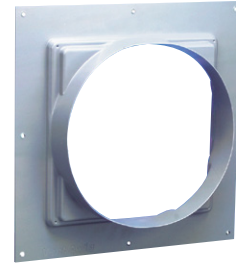

Single Spigots

Single spigots in 300mm and 450mm square modular sizes. Used to connect Flexible ducting to Mounting boxes and other modular accessories or can be fixed directly to walls.

Manufactured in flame retardant high impact thermoplastic.

Unit Size	Nom Dia	Stock Ref
6"	175mm(B)	560637
6"/7"	225mm(B)	560639
7"	250mm(A)	560640
9"	300mm(A)	560642
9"	300mm(B)	566142
12"	400mm(B)	566146

Vent-Axia single spigot		
Unit Size	'A' Ø	Module Size
6"	B 175mm	300mm
6"	B 225mm	300mm
7"	B 225mm	300mm
7"	A 250mm	300mm
9"	A 300mm	300mm
9"	B 300mm	450mm
12"	B 400mm	450mm

Ventilation Accessories

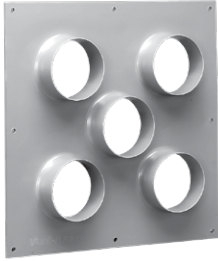

Multi-Spigot Plates

Available with 2, 3, 4 or 5 circular spigots of 100mm diameter. Multi-spigot plates are used in conjunction with 100mm Flexible ducting and other modular accessories to ventilate several small areas especially internal WCs. For use with Size 6 units only. Manufactured in flame retardant high impact recyclable thermoplastic.

Available in 300mm square modular size.

Description	Stock Ref
2-3-4 Spigots	560734
5 Spigots	560735



T-Series Direct Mount Spigots

Used to connect Flexible ducting directly to the inlet side of all T-Series models and the outlet side of T-Series Window models.

Manufactured in flame-retardant high impact recyclable thermoplastic.

Unit Size	Stock Ref
6" All models	560501
7" All models	560502
9" WW/RF	560503
9" WL/PL	560504
12" All models	560505



T-Series Darkroom Cowl Assembly

For use with all T-Series fans for Darkroom applications. Designed to give light protection.

Can also be used in other light sensitive areas such as medical, dental and veterinarian applications.

Unit Size	Stock Ref
6"	460585
7"	460586
9"	460587
12"	460588

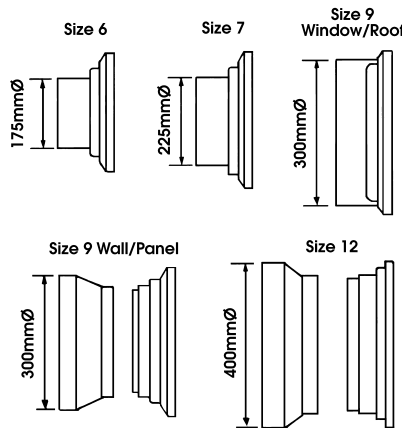



Plenum Boxes

The Plenum box allows square grilles and diffusers to connect to circular duct. Each box size has a two diameter circular spigot for maximum versatility. The box is deep enough to accommodate both a double deflection grille and opposed blade damper.

Manufactured in flame retardant high impact recyclable thermoplastic.

Size	Stock Ref	Nom. Ø
200mm	560601	125/150mm
250mm	560602	150/175mm
300mm	560603	200/225mm
300mm	560604	250/300mm
450mm	560605	315/400mm

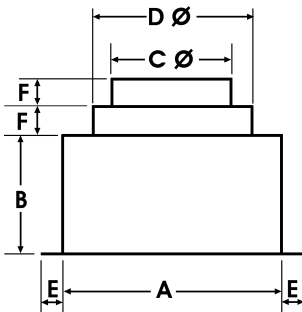

Dimensions (mm)

Stock Ref.	A	B	C Ø	D Ø	E	F
560601	200	130	125	150	25	25
560602	250	130	150	175	25	25
560603	300	130	200	225	25	25
560604	300	130	250	300	25	25
560605	450	130	315	400	25	25



Single Deflection Grilles

Single deflection grilles are suitable for either side wall or exposed duct applications.

The Single deflection grille has a single row of blades which permit up to 45° deflection of the air in one plane.

Satin silver finish.

Size 6/7 fits 300mm square modular size and size 9/12 fits 450mm square modular size.

Module size	Stock Ref
200mm sq	561370
250mm sq	561371
300mm sq	561372
450mm sq	561373

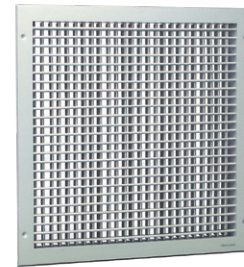

Double Deflection Grilles

Double deflection grilles are suitable for supply air for either side wall or exposed duct applications.

The Double deflection grille has two rows of blades set at 90° apart which permit up to 45° deflection of the air in two planes.

Satin silver finish.

Size 6/7 fits 300mm square modular size and size 9/12 fits 450mm square modular size.

Module size	Stock Ref
200mm sq	561380
250mm sq	561381
300mm sq	561382
450mm sq	561383

Ventilation Accessories



Eggcrate Grilles

Eggcrate grilles can be used for air replacement or air extract purposes.

Used underneath Roof plate assemblies with Roof models, underneath single spigots in ceilings, underneath mounting boxes and on the inside faces of walls that have units in fixed and removable wall plates on the outside of the wall.

Comprising a 13mm square by 13mm deep mesh eggcrate core housed in a frame which has a satin silver or white finish.

Size 6/7 fits 300mm square modular size and size 9/12 fits 450mm square modular size.

Size 6/7 - 785cm² free area
Size 9/12 - 1810cm² free area

200mm Sq - 340 cm²
250mm Sq - 530 cm²

Satin finish.

Module size	Stock Ref
200mm sq	561303
250mm sq	561305
300mm sq	561301
450mm sq	561302

White finish.

Module size	Stock Ref
125mm sq	560846
200mm sq	560847
250mm sq	560848
300mm sq	560849
450mm sq	560850



Opposed Blade Dampers

Opposed blade dampers are used to regulate air flow through all Vent-Axia grilles and diffusers. Key operated.

This action ensures that the downstream airflow is non-directional when the damper is in the partially closed position. Opposed blade dampers have aluminium blades and the frame is left in natural mill finish.

Can be used in conjunction with Eggcrate, Single deflection and Double deflection grilles.

Size 6/7 fits 300mm square modular size and size 9/12 fits 450mm square modular size.

Module size	Stock Ref
200mm sq	561341
250mm sq	561342
300mm sq	561343
450mm sq	561344



Filtered Inlet Grille

For ceiling, panel or glass mounting. Consists of a size 6 grille, washable filter, adaptor kit and a stepped spigot to suit 100, 125 or 150mm diameter ducting.

Grille size: 226mm x 220mm
Spigot depth: 100mm
Fixing hole diameter: 184mm

Stock Ref
W563536



4-Way Diffusers

Manufactured in polypropylene plastic. Four diffuser cassettes can be set for downward or 45° discharge in any of sixteen directional combinations.

Colour: Ivory

Neck Size	Stock Ref
225mm	10546230
300mm	10546300
350mm	10546350



Neck Adaptor

Used to connect Flexible ducting directly to 4-way diffusers. Integral volume control damper for duct sizes up to 300mm.

Diffuser	4-Way	
Duct Size	Neck Size	Stock Ref
150mm Ø	225mm	10547150
200mm Ø	225mm	10547200
250mm Ø	300mm	10547250
300mm Ø	350mm	10547300



Window/Wall/Ceiling Termination Sets

Used to terminate Flexible ducting at windows. Can be used with the Extended fixing rod set or Fixing plates for termination at walls. Used with Flexible ducting and Worm drive clips.

Consists of a Direct mount spigot, Adaptor kit, Window grille and all screws.

Unit Size	Spigot DiaØ	Stock Ref
6"	175mm	W560151
7"	225mm	W560152
9"	300mm	W560153
12"	400mm	W560154

Other sizes	Spigot DiaØ	Stock Ref
	100/125/150mm	W10554150
	200mm	W10554200
	250mm	W10554250
	315mm	W10554315

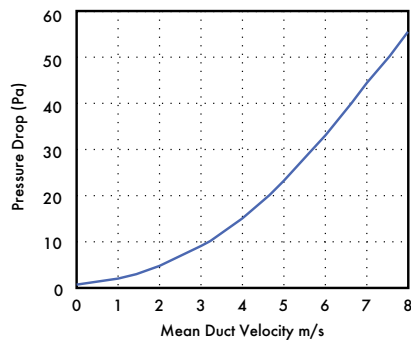

Air Replacement Non-Vision Grilles

Satin finish

Non-vision grilles consist of a single row of overlapping chevron vanes. Used as transfer grilles for doors or partitions, the overlapping vanes prevent through-vision.

Module size	Stock Ref
300mm sq	561311
450mm sq	561312

Black finish

In addition to preventing through-vision the black finish also limits light transference. Use two grilles back to back for darkroom applications.

Module size	Stock Ref
300mm sq	561321
450mm sq	561322



Roof Termination Sets

Used to terminate Flexible ducting at roofs. Consists of: Direct mount spigot, Adaptor kit, Roof cowl, Deflector and all screws. Can be used with Roof Plate Assemblies for installation on flat roofs.

T-series units

Size	Spigot Ø	Stock Ref
6"	175mm	560161
7"	225mm	560162
9"	300mm	560163
12"	400mm	560164

Vent-Axia roof termination

Diameter	Stock Ref
100/125/150mm	10555150
200mm	10555200
250mm	10555250
315mm	10555315

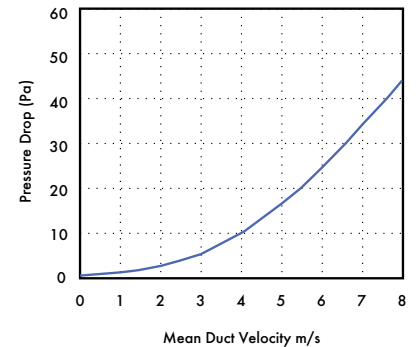

Ventilation Accessories



Air Replacement Non-Vision Door Grilles with Matching Flanges

Non-vision grilles consist of a single row of overlapping chevron vanes to prevent through-vision, supplied with matching flanges. The grille is fitted to one side of the door with the matching flange on the other side.

Suitable for door thicknesses of 19-49mm.

Available in Silver or Brown finish, in two sizes, 600 x 150 and 600 x 300mm.

Satin finish

Size	Stock Ref
600 x 150mm	561390
600 x 300mm	561391

Brown finish

Size	Stock Ref
600 x 150mm	560900
600 x 300mm	560901



Heavy Duty T-Series Wall Grilles

Tough aluminium construction for accessible public areas. Fits T-Series wall models in place of existing external grille. Finish T-Series grey.

Size	Stock Ref
6"	452725
7"	452726
9"	452727
12"	452728



External Louvre Mill and Brown Finish

Weather resistant external louvres are suitable for air intake or discharge and for use with ducting on external walls.

The narrow blade construction has a 38mm pitch set at 45° with a depth of 41mm and an integral rain lip.

Standard 32mm wide undrilled outer flanges in aluminium have fully welded mitre corners as standard.

Size 6/7 fits 300mm square modular size and size 9/12 fits 450mm square modular size.

Size 6/7 - 345cm² free area
Size 9/12 - 824cm² free area

Satin finish

Size	Stock Ref
225mm sq	561350
300mm sq	561351
400mm sq	561355
450mm sq	561352

Brown finish

Size	Stock Ref
225mm sq	560910
300mm sq	560911
400mm sq	560912
450mm sq	560913

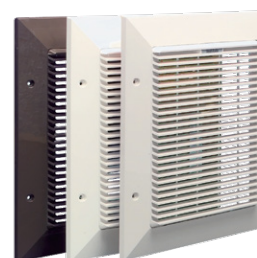

Louvre Grilles

Louvre grilles can be used for air replacement, for extract purposes and as an external louvre. Available in four sizes, the assembly fits over rather than into the aperture making it especially useful where there are space restrictions within the duct.

Manufactured in thermoplastic. Choice of three colours: White, Brown and Grey.

Size 6	- 190cm ² free area
Size 7	- 335cm ² free area
Size 9	- 415cm ² free area
Size 12	- 705cm ² free area

Grille Dimensions (mm)

Size	W x H
6"	= 310 x 303
7"	= 352 x 345
9"	= 391 x 388
12"	= 470 x 467

The grilles and surrounds are moulded in ABS plastic to tone in with building materials, therefore an equivalent BS or RAL colour reference cannot be given.

Unit Size	Colour	Stock Ref
6"	Grey	W561431
6"	Brown	561411
6"	White	561421
7"	Grey	W561432
7"	Brown	561412
7"	White	561422
9"	Grey	W561433
9"	Brown	561413
9"	White	561423
12"	Grey	W561434
12"	Brown	561414
12"	White	561424



Roof Plate Assemblies

Vent-Axia roof plate assemblies are manufactured in high impact recyclable thermoplastic. They consist of a strong one piece moulded plate with extended sides to assist flashing and weather protection. A separate sub-frame is provided for permanent fixing to the roof kerb. The Vent-Axia Roof model is then fitted to the plate using a suitable sealing compound between the Cowl and plate, ensuring a weather-tight seal.

Size	Stock Ref
6"	560136
7"	560137
9"	560139
12"	560142

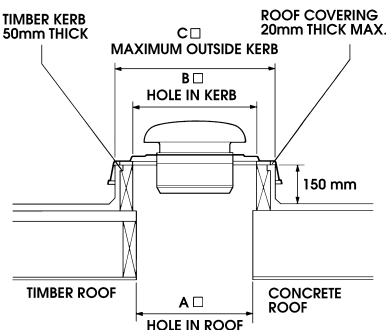

Size	A	B	C
6"	300mm	335mm	465mm
7"	300mm	335mm	465mm
9"	450mm	490mm	615mm
12"	450mm	490mm	615mm

In addition to the size 6, 7, 9 & 12 Roof Termination Sets, the Roof Plate Assemblies can also be used with the following Roof Terminations part numbers.

- 10555150 use size 6 Roof Plate Assembly
- 10555200 use size 7 Roof Plate Assembly
- 10555250 use size 9 Roof Plate Assembly
- 10555315 use size 12 Roof Plate Assembly



Joining Pieces

Used to join lengths of flexible ducting to give a long-lasting airtight connection.

Duct Size	Stock Ref
100mm Ø	561804
125mm Ø	561805
150mm Ø	561806
175mm Ø	561807
200mm Ø	561808
225mm Ø	561809
250mm Ø	561810
300mm Ø	561812
315mm Ø	561813
400mm Ø	561816



Worm Drive Clips

Stainless steel tightening band with quick-fix screwed ends for securing flexible ducting.

Max. Ø	Stock Ref
110mm	561704
215mm	561707
270mm	561710
380mm	561715
525mm	561720
660mm	561726

Roof Units™ Industrial

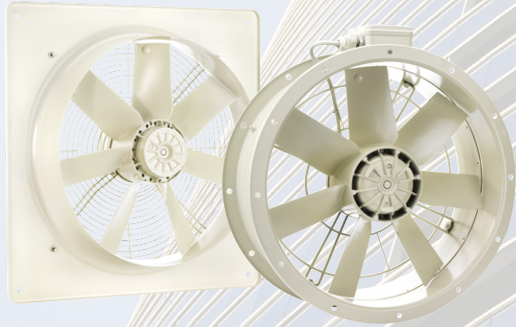

Roof Units™ from Vent-Axia

The Roof Units™ name has long been associated with high quality ventilation products at affordable prices. With ERP compliance assured you can be certain of high quality ventilation products meeting the exacting demands of today's buildings.

The extensive Roof Units™ product range includes the Euroseries® Axial plate, short cased & roof fans, as well as inline centrifugal extract fans and twin fans. When matched with the Roof Units™ and Vent-Axia ranges of controllers, flexible ducting and other accessories you can be certain of fulfilling the complete installation from one supplier.

Characterised by design excellence, Roof Units™ fans are purpose designed to deliver controllable outputs of up to 15m³/s, plus the right balance of airflow, pressure development, quietness and energy efficiency for every type of project.

The Euroseries® range of Axial bladed fans cover plate, short cased & roof variants, all fully speed controllable, incorporating modern high efficiency external rotor motors with single piece die-cast aluminium rotor/impellers offering smoother running & giving longer reliable service life.

Vent-Axia®

	EuroSeries® (ESP) Plate Mounted Axial Fans	M:3-M:10
	EuroSeries® (ESC) Short Case Axial Fans	M:11-M:18
	EuroSeries® (ESR) Fan Assisted Roof Cowls	M:19-M:26
	Quiet Pack (QP) In-Line Centrifugal Duct Fans	M:27-M:30
	Quiet Pack (QPTW) In-Line Twin Fans	M:31-M:34
	Slimpak EC Box Fan (SLP EC) In-Line Centrifugal Duct Fans	M:35-M:40
	Slimpak EC Twin Fan (SLPT EC) In-Line Twin Duct Fans	M:41-M:46
	EuroSeries® (SDX) In-Line Centrifugal Duct Fans	M:47-M:50
	Speed Controllers Single & Three Phase	M:51-M:52
	Starter & Overloads	M:53
	Sonex Circular Sound Attenuators	M:54
	Pyrocheck (CVT) Intumescent Fire Dampers	M:55
	Unitex Roof Cowl System	M:56
	Unitex Wall Terminal (SA & QSA)	M:57

EuroSeries[®] (ESP)

- Die cast aluminium impellers
- Fully speed controllable
- Air Volumes up to 13.89m³/s
- Sizes 250 to 1000 dia protected to IP54
- Operating Temperatures from -40°C up to +70°C Motor
- Insulation Class F
- Thermal overload for motor protection
- Reversible - Supply or Extract
- Tough epoxy paint finish
- Quality Assurance to BS EN ISO 9001:1994
- Performance tested to ISO 5801



The EuroSeries[®] ESP axial blade plate fans, feature a single shot die cast aluminium blade and external rotor motor design.

The EuroSeries[®] ESP range is available in eleven sizes with the extract performances up to 13.89m³/s, with pressure characteristics of up to 300Pa. All units are designed for speed controllable.

Impellers

All sizes are supplied with cast aluminium impellers, ensuring performance when working against outdoor conditions and abrasive airflow. Where fans are reversible for Intake a -30% drop in performance can be expected.

Motors

External rotor motors are specially designed and styled for this range of fan. Ball bearings are greased for life. Rotors are dynamically balanced to ISO 1940. Sizes 250-1000mm, motors are protected to IP54, against dust and moisture complying with BS EN 60529:1992. They are ribbed aluminium body castings for efficient cooling. Motor insulation is Class 'F' (from -40°C to +70°C).

Electrical

Single phase 220-240V 50Hz. Capacitor start and run. Three phase 380-415V 50Hz. An IP54 terminal box are supplied with 20mm and PGII entry. All motors are fitted with thermal overload protection which should be wired into all controller circuits and into starter contactors. Models are available with either 2,4,6 or 8 pole motors.

Terminal Box

Terminal Box to IP54 as standard, protected against dust and water from any angle allowing outside applications.

Performance

The fan performance is in accordance with tests to BS848 Part 1 1980.

Sound Levels

Fan sound levels are measured in a reverberant chamber in accordance with BS848 Part 2 1985. Published dB(A) figures are free field sound pressure levels at 3m with spherical propagation at a reference level of 2×10^{-5} Pa (20 micro-Pascal). The sound power level spectra figures are dB with reference level of 10^{-12} Watts (1 pico-watt). To ensure minimum noise levels during speed control, an auto transformer speed control is recommended.

Accessories

A full range of accessories:

- Electronic Speed Controllers
- Auto Transformer Speed Controllers
- D.O.L. Starters & Overloads
- Discharge Guards
- Louvre Shutters

Dimensions (mm)

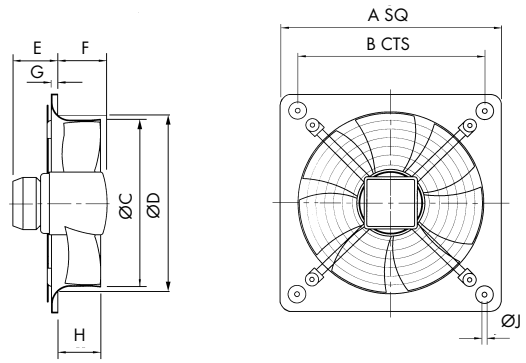

Dia	A	B	ØC	ØD	E	F	G	H	ØJ	kg
250	370	320	256.5	264.5	84	80	6	80	9	3.4
315	430	380	320	328	84	84	19	70	9	6.3
355	485	435	367	372	86	97	21	75	9	7.3
400	540	490	412	420	93	100	12	88	9	10.2
450	575	535	463	480	86	139	14	96	11	15.8
500	655	615	517	528	84	141	16	104	11	17.3
560	725	675	568	589	81	142.5	16	119	11	24
630	805	750	643	664	82	142.5	20	130	11	45
710	850	810	720	763	37	176.5	20	150	14.5	31
800	970	910	804	869	34	244	17	193	14.5	38
1000	1170	1110	1009	1067	40	284	20	200	14.5	84

Performance Guide

250 to 315 dia. - 1 Phase - 2 & 4 Pole

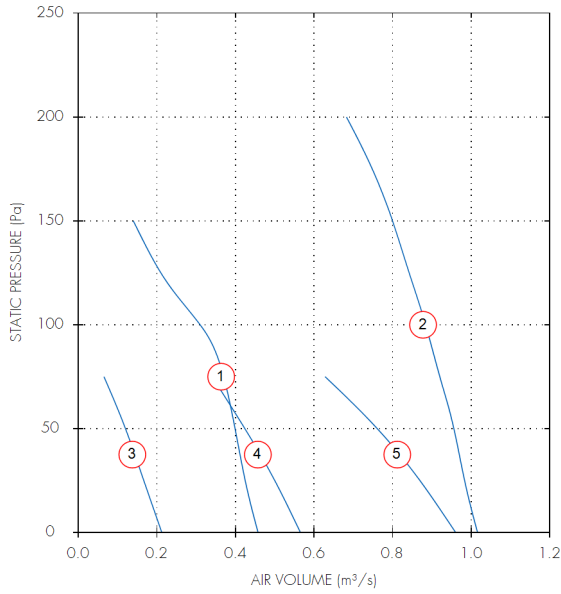

250 to 315 dia. - 3 Phase - 2 & 4 Pole

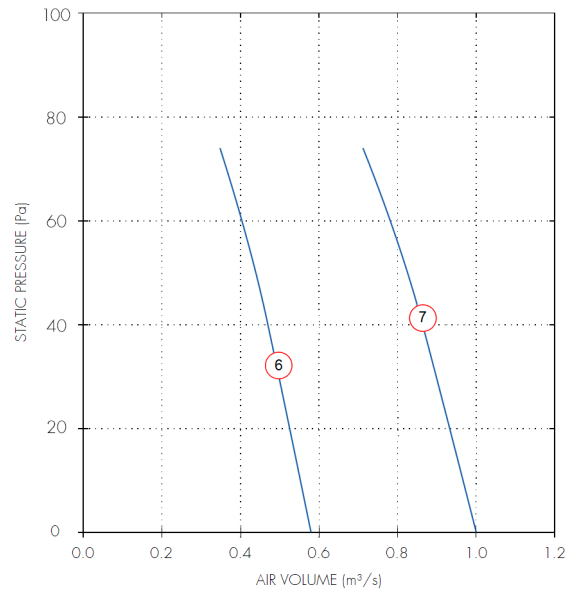

Dia.	Motor Phase	Stock Ref	Poles	r.p.m	IP Rating	Curve Ref.	0	m³/s @ Pa				Motor kW	S.C. Amps	F.L.C Amps	dB(A) @ 3m
								50	100	150	200				
250	1	ESP25012	2	2440	IP44	1	0.46	0.4	0.31	0.14		0.12	1.15	0.54	59
315	1	ESP31512	2	2690	IP54	2	1.02	0.96	0.88	0.8	0.68	0.56	7.2	2.4	64
250	1	ESP25014	4	1340	IP44	3	0.21	0.12				0.04	0.3	0.16	44
315	1	ESP31514	4	1300	IP54	4	0.57	0.42				0.15	1.38	0.7	50
355	1	ESP35514	4	1330	IP54	5	0.96	0.76				0.19	1.45	0.84	53
315	3	ESP31534	4	1390	IP54	6	0.58	0.44				0.11	2.1	0.27	46
355	3	ESP35534	4	1370	IP54	7	1	0.83				0.17	1.35	0.37	49

For fans wired to reverse run, duty reduced by 30%. ESP25012, ESP31512 and ESP25014 not suitable for reverse airflow.

Sound Power Level Spectra dB (ref 10⁻¹² Watts)

Dia.	Motor Phase	Stock Ref	Poles	Spectrum	dB(A) @ 3m								
					63	125	250	500	1k	2k	4k	8k	
250	1	ESP25012	2	Inlet	69	70	76	76	70	70	67	59	57
250	1	ESP25012	2	Outlet	69	70	76	76	70	70	67	59	57
315	1	ESP31512	2	Inlet	69	73	79	74	74	76	73	66	61
315	1	ESP31512	2	Outlet	69	73	79	74	74	76	73	66	61
250	1	ESP25014	4	Inlet	70	72	63	58	54	52	45	35	41
250	1	ESP25014	4	Outlet	70	72	63	58	54	52	45	35	41
315	1	ESP31514	4	Inlet	70	68	66	61	60	62	58	51	47
315	1	ESP31514	4	Outlet	70	68	66	61	60	62	58	51	47
355	1	ESP35514	4	Inlet	65	70	67	65	64	64	62	55	50
355	1	ESP35514	4	Outlet	65	70	67	65	64	64	62	55	50
315	3	ESP31534	4	Inlet	64	67	69	63	62	60	58	53	47
315	3	ESP31534	4	Outlet	64	67	69	63	62	60	58	53	47
355	3	ESP35534	4	Inlet	58	73	63	64	64	65	64	58	50
355	3	ESP35534	4	Outlet	58	73	63	64	64	65	64	58	50

Performance Guide

400 to 630 dia. - 1 Phase - 4 Pole

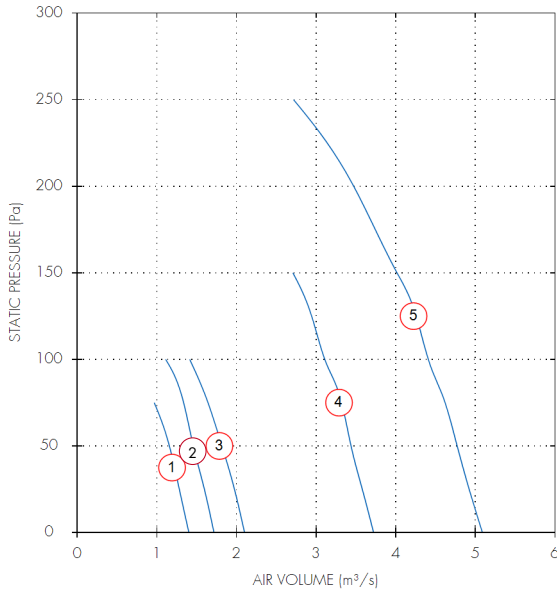

400 to 560 dia. - 3 Phase - 4 Pole

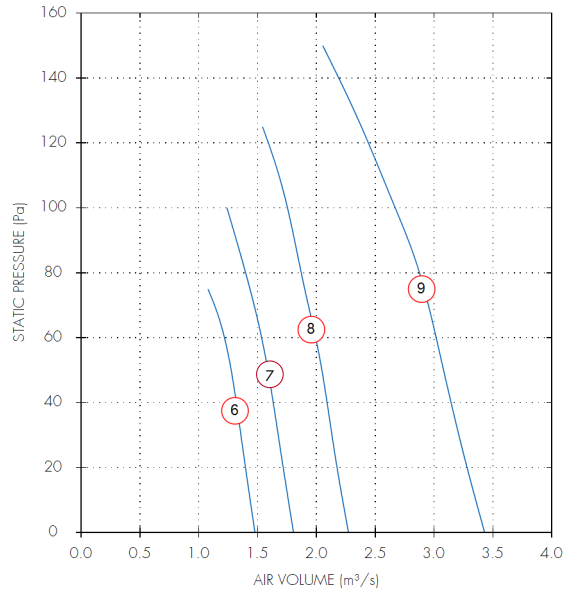

Dia.	Motor Phase	Stock Ref	Poles	r.p.m	IP Rating	Curve Ref.	m³/s @ Pa					Motor kW	S.C. Amps	F.L.C Amps	dB(A) @ 3m
							0	50	100	150	200				
400	1	ESP40014	4	1350	IP54	1	1.4	1.16				0.29	2.4	1.45	56
450	1	ESP45014	4	1370	IP54	2	1.72	1.46	1.11			0.36	3.6	1.6	61
500	1	ESP50014	4	1290	IP54	3	2.1	1.82	1.41			0.51	4.3	2.3	55
560	1	ESP56014	4	1320	IP54	4	3.72	3.44	3.11	2.71		1.35	9.3	6	63
630	1	ESP63014	4	1320	IP54	5	5.09	4.77	4.41	4.02	3.47	2.2	28	9.9	70
400	3	ESP40034	4	1350	IP54	6	1.48	1.27				0.26	2.1	0.56	51
450	3	ESP45034	4	1380	IP54	7	1.8	1.59	1.24			0.36	2.6	0.8	56
500	3	ESP50034	4	1380	IP54	8	2.27	2.05	1.75			0.55	4.2	1.05	58
560	3	ESP56034	4	1220	IP54	9	3.43	3.08	2.67	2.05		1.25	7.7	2.2	70

For fans wired to reverse run, duty reduced by 30%.

Sound Power Level Spectra dB (ref 10⁻¹² Watts)

Dia.	Motor Phase	Stock Ref	Poles	Spectrum	dB(A) @ 3m								
					63	125	250	500	1k	2k	4k	8k	
400	1	ESP40014	4	Inlet	70	72	67	66	65	65	64	56	51
400	1	ESP40014	4	Outlet	70	72	67	66	65	65	64	56	51
450	1	ESP45014	4	Inlet	69	76	73	72	70	71	70	62	57
450	1	ESP45014	4	Outlet	69	76	73	72	70	71	70	62	57
500	1	ESP50014	4	Inlet	65	75	69	70	70	71	69	62	56
500	1	ESP50014	4	Outlet	65	75	69	70	70	71	69	62	56
630	1	ESP63014	4	Inlet	82	86	79	79	80	78	75	70	64
630	1	ESP63014	4	Outlet	82	86	79	79	80	78	75	70	64
400	3	ESP40034	4	Inlet	62	73	65	65	67	69	67	60	53
400	3	ESP40034	4	Outlet	62	73	65	65	67	69	67	60	53
450	3	ESP45034	4	Inlet	65	82	75	76	73	72	69	62	58
450	3	ESP45034	4	Outlet	65	82	75	76	73	72	69	62	58
500	3	ESP50034	4	Inlet	67	71	69	72	70	71	68	61	56
500	3	ESP50034	4	Outlet	67	71	69	72	70	71	68	61	56
560	3	ESP56034	4	Inlet	85	79	77	76	76	75	72	66	61
560	3	ESP56034	4	Outlet	85	79	77	76	76	75	72	66	61

Performance Guide

630 to 710 dia. - 3 Phase - 4 Pole

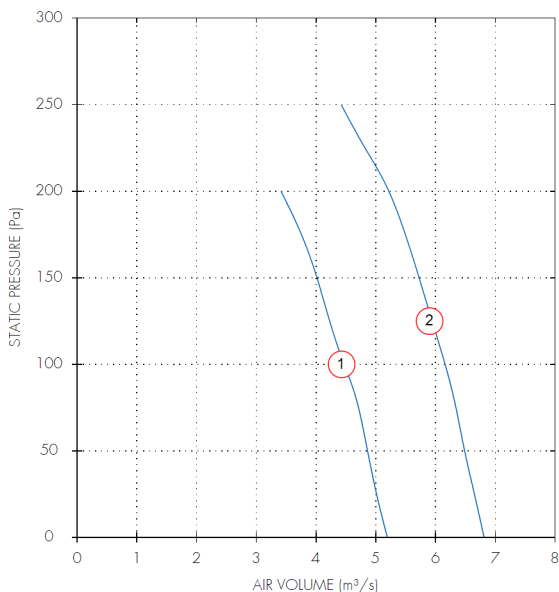

355 to 710 dia. - 1 Phase - 6 Pole

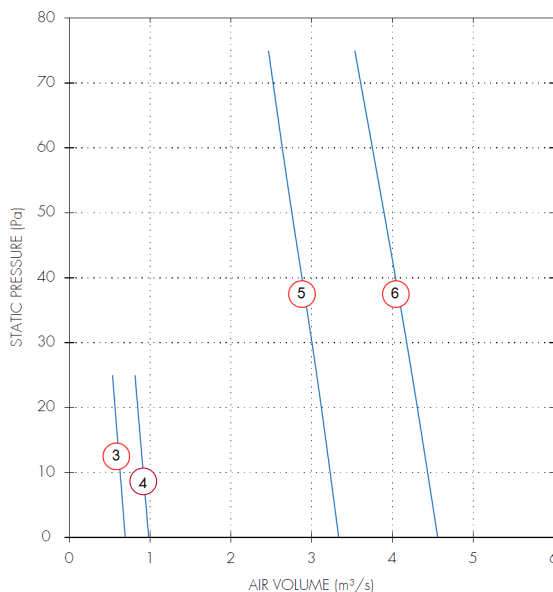

Dia.	Motor Phase	Stock Ref	Poles	r.p.m	IP Rating	Curve Ref.	m ³ /s @ Pa						Motor kW	S.C. Amps	F.L.C Amps	dB(A) @ 3m
							0	25	50	100	150	200				
630	3	ESP63034	4	1360	IP54	1	5.19	5.01	4.86	4.47	4.02	3.41	1.9	17	3.2	64
710	3	ESP71034	4	1290	IP54	2	6.81	6.65	6.49	6.16	5.72	5.22	2.9	20	5.3	72
355	1	ESP35516	6	950	IP54	3	0.69	0.53					0.09	1.2	0.46	44
400	1	ESP40016	6	940	IP54	4	0.98	0.81					0.1	1.4	0.48	45
630	1	ESP63016	6	880	IP54	5	3.33	3.06	2.75				0.6	5.3	2.7	57
710	1	ESP71016	6	850	IP54	6	4.56	4.24	3.89				0.89	8	4.1	60

For fans wired to reverse run, duty reduced by 30%.

Sound Power Level Spectra dB (ref 10⁻¹² Watts)

Dia.	Motor Phase	Stock Ref	Poles	Spectrum	dB(A) @ 3m								
					63	125	250	500	1k	2k	4k	8k	
630	3	ESP63034	4	Inlet	71	88	82	83	82	81	78	72	67
630	3	ESP63034	4	Outlet	71	88	82	83	82	81	78	72	67
710	3	ESP71034	4	Inlet	80	87	86	88	89	86	83	79	72
710	3	ESP71034	4	Outlet	80	87	86	88	89	86	83	79	72
355	1	ESP35516	6	Inlet	59	59	60	57	56	57	55	46	42
355	1	ESP35516	6	Outlet	59	59	60	57	56	57	55	46	42
400	1	ESP40016	6	Inlet	76	74	70	65	63	58	52	44	48
400	1	ESP40016	6	Outlet	76	74	70	65	63	58	52	44	48
630	1	ESP63016	6	Inlet	88	85	81	77	76	70	64	58	60
630	1	ESP63016	6	Outlet	88	85	81	77	76	70	64	58	60
710	1	ESP71016	6	Inlet	83	83	84	80	78	74	70	72	63
710	1	ESP71016	6	Outlet	83	83	84	80	78	74	70	72	63

Performance Guide

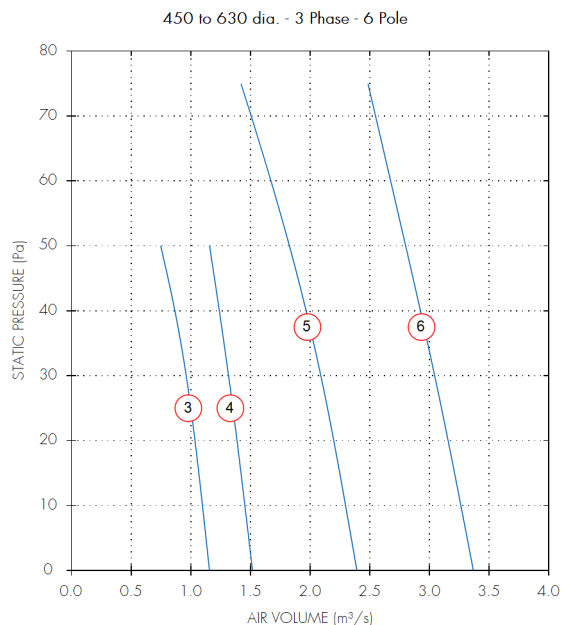
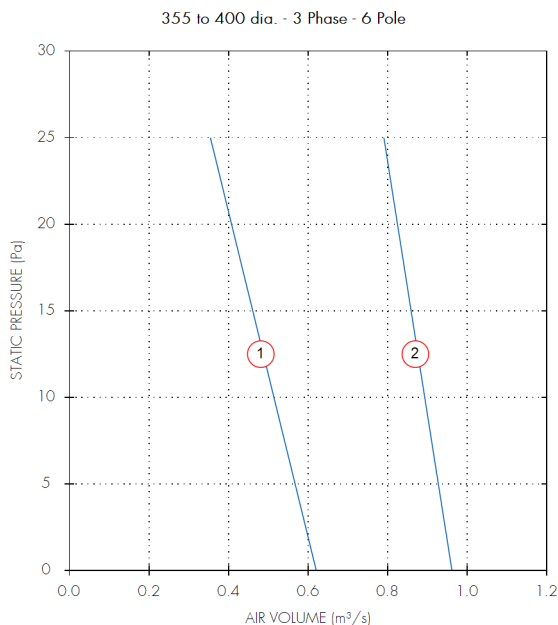

Dia.	Motor Phase	Stock Ref	Poles	r.p.m	IP Rating	Curve Ref.	m³/s @ Pa			Motor kW	S.C. Amps	F.L.C Amps	dB(A) @ 3m
							0	25	50				
355	3	ESP35536	6	910	IP54	1	0.62	0.35		0.09	0.5	0.25	45
400	3	ESP40036	6	920	IP54	2	0.96	0.79		0.11	0.9	0.28	50
450	3	ESP45036	6	890	IP54	3	1.16	1	0.75	0.12	1	0.28	51
500	3	ESP50036	6	900	IP54	4	1.52	1.35	1.16	0.23	1.5	0.56	56
560	3	ESP56036	6	860	IP54	5	2.39	2.14	1.83	0.36	1.75	0.74	56
630	3	ESP63036	6	890	IP54	6	3.37	3.1	2.8	0.59	3.6	1.3	59

For fans wired to reverse run, duty reduced by 30%.

Sound Power Level Spectra dB (ref 10⁻¹² Watts)

Dia.	Motor Phase	Stock Ref	Poles	Spectrum	dB								dB(A) @ 3m
					63	125	250	500	1k	2k	4k	8k	
355	3	ESP35536	6	Inlet	60	61	60	56	56	56	54	46	42
355	3	ESP35536	6	Outlet	60	61	60	56	56	56	54	46	42
400	3	ESP40036	6	Inlet	60	60	62	59	60	60	58	50	45
400	3	ESP40036	6	Outlet	60	60	62	59	60	60	58	50	45
450	3	ESP45036	6	Inlet	63	72	66	63	63	62	59	48	48
450	3	ESP45036	6	Outlet	63	72	66	63	63	62	59	48	48
500	3	ESP50036	6	Inlet	78	73	68	67	68	66	59	51	52
500	3	ESP50036	6	Outlet	78	73	68	67	68	66	59	51	52
560	3	ESP56036	6	Inlet	67	72	72	68	68	68	65	57	53
560	3	ESP56036	6	Outlet	67	72	72	68	68	68	65	57	53
630	3	ESP63036	6	Inlet	67	78	76	74	73	72	77	59	60
630	3	ESP63036	6	Outlet	67	78	76	74	73	72	77	59	60

Performance Guide

710 to 800 dia. - 3 Phase - 6 Pole

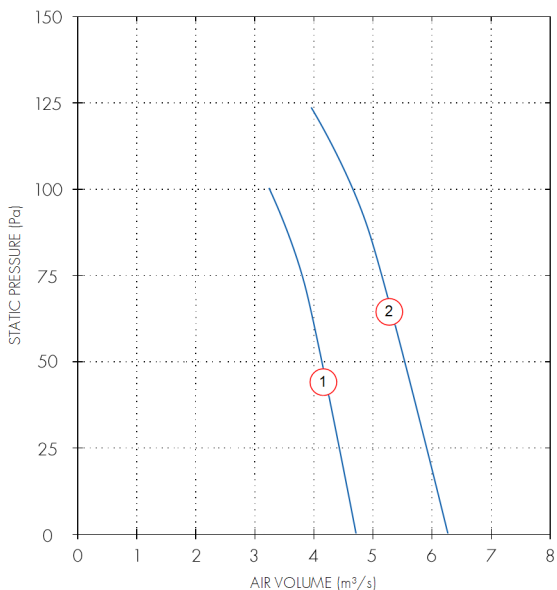

710 to 800 dia. - 3 Phase - 8 Pole

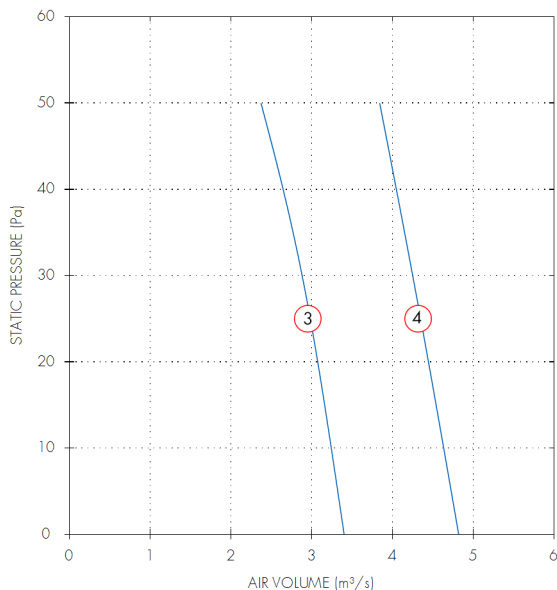

Dia.	Motor Phase	Stock Ref	Poles	r.p.m	IP Rating	Curve Ref.	m ³ /s @ Pa			Motor kW	S.C. Amps	F.L.C Amps	dB(A) @ 3m
							0	50	100				
710	3	ESP71036	6	860	IP54	1	4.71	4.11	3.29	1.1	7.7	2.2	62
800	3	ESP80036	6	900	IP54	2	6.3	5.58	4.67	1.4	9.8	2.7	64
710	3	ESP71038	8	630	IP54	3	3.4	2.37		0.43	3.3	1.1	55
800	3	ESP80038	8	670	IP54	4	4.82	3.84		0.69	5	1.75	58

For fans wired to reverse run, duty reduced by 30%.

Sound Power Level Spectra dB (ref 10⁻¹² Watts)

Dia.	Motor Phase	Stock Ref	Poles	Spectrum	dB								dB(A) @ 3m
					63	125	250	500	1k	2k	4k	8k	
710	3	ESP71036	6	Inlet	80	77	78	75	76	75	70	64	60
710	3	ESP71036	6	Outlet	80	77	78	75	76	75	70	64	60
800	3	ESP80036	6	Inlet	73	83	79	75	75	77	74	64	62
800	3	ESP80036	6	Outlet	73	83	79	75	75	77	74	64	62
710	3	ESP71038	8	Inlet	75	75	73	71	72	70	64	57	56
710	3	ESP71038	8	Outlet	75	75	73	71	72	70	64	57	56
800	3	ESP80038	8	Inlet	75	75	73	71	72	70	64	57	56
800	3	ESP80038	8	Outlet	75	75	73	71	72	70	64	57	56

Models & Accessories

Fan Stock Ref	Speed Controllers			Overload Stock Ref	Fan Stock Ref	Speed Controller Auto Transfor. Stock Ref	Starter Stock Ref	Overload Stock Ref	
	Elect 1ph Stock Ref	Auto Transfor. Stock Ref	Starter Stock Ref						
1 Phase - 4 Pole					3 Phase - 4 Pole				
ESP31514	SC5001	SPM5020	444744	444699	ESP31534	RDTK10	444747	444697	
ESP35514	SC5050TK	SPM5020	444744	444699	ESP35534	RDTK10	444747	444698	
ESP40014	SC5030TK	SPM5020	444744	444701	ESP40034	RDTK10	444747	444699	
ESP45014	SC5030TK	SPM5035	444744	444701	ESP45034	RDTK10	444747	444699	
ESP50014	SC5030TK	SPM5035	444744	444702	ESP50034	RDTK20	444747	444700	
ESP56014	SC5010TK	SPM5075	444744	444704	ESP56034	RDTK40	444747	444701	
ESP63014	-	-	444744	444706	ESP63034	RDTK40	444747	444702	
					ESP71034	RDTK70	444747	444703	
1 Phase - 6 Pole					3 Phase - 6 Pole				
ESP35516	SC5030TK	SPM5020	444744	444698	ESP35536	RDTK10	444747	444697	
ESP40016	SC5030TK	SPM5020	444744	444699	ESP40036	RDTK10	444747	444697	
					ESP45036	RDTK10	444747	444697	
					ESP50036	RDTK10	444747	444699	
					ESP56036	RDTK10	444747	444699	
ESP63016	SC5050TK	SPM5035	444744	444702	ESP63036	RDTK20	444747	444700	
ESP71016	SC5050TK	SPM5060	444744	444703	ESP71036	RDTK40	444747	444702	
					ESP80036	RDTK40	444747	444702	
					3 Phase - 8 Pole				
					ESP71038	RDTK20	444747	444700	
					ESP80038	RDTK20	444747	444701	

*Not suitable for voltage speed control. Inverter speed control with sine filters only.

Size	Roof Cowl Assembly Stock Ref	Louvre Shutter Stock Ref	Impeller Discharge Side Guard Stock Ref	Imp. Disch. Guard when used with LS shutter Stock Ref
250	RCZ300	LS250	10502325	10502375
315	RCZ300	LS315	10502325	10502375
355	RCZ300	LS350	10502375	10502450
400	RCZ400	LS400	10502450	10502525
450	RCZ400	LS450	10502525	10502630
500	RCZ500	LS500	10502525	10502630
560	RCZ500	LS560	10502630	10502630
630	RCZ630	LS630	10502630	10502800
710	RCZ630	LS710	10502800	10502800
800	RCZ800	LS800	10502800	105021000

Note:

- The Standard roof cowl colour is BS 00A 05 (Goose Wing Grey), for all special B.S. or RAL colours contact Vent-Axia.
- When speed control is required a 5 step auto transformer speed controller is recommended, to ensure low noise levels.
- All 3 phase models are suitable for frequency inverter speed control.
- Vent-Axia only recommends using inverters with integral sine filters for reliable operation.

EuroSeries[®] (ESC)

- External rotor motors
- Die cast aluminium impellers
- Fully speed controllable
- Air Volumes up to 13.89m³/s
- Sizes 250 to 1000 protected to IP54
- Operating Temperatures from -40°C up to +70°C
- Motor Insulation Class F
- HOT SPOT Protection
- Reversible for supply or extract
- Tough epoxy paint finish
- Quality Assurance to BS EN ISO 9001:1994
- Performance tested to BS848 Part 1 1980



The EuroSeries[®] ESC Short Cased axial blade fans, feature a single shot die cast aluminium blade & external rotor motor design.

The EuroSeries[®] ESC range is available in eleven sizes with the extract performances up to 13.89m³/s, with pressure characteristics of up to 300Pa. All units are designed for & fully speed controllable.

Impellers

All sizes are supplied with cast aluminium impellers, ensuring performance when working against outdoor conditions and abrasive airflow.

Motors

External rotor motors are specially designed and styled for this range of fan. Ball bearings are greased for life. Rotors are dynamically balanced to ISO 1940. Sizes 250-1000mm, motors are protected to IP54, against dust and moisture complying with BS EN 60529:1992. They are ribbed aluminium body castings for efficient cooling. Motor insulation is Class 'F' (from -40°C to +70°C).

Electrical

Single phase 220-240V 50Hz. Capacitor start and run. Three phase 380-415V 50Hz. An IP54 terminal box are supplied with most models with 20mm and PG11 entry. All motors are fitted with thermal overload Protection which should be wired into all controller circuits and into starter contactors. Models are available with either 2,4, 6 & 8 pole motors.

Terminal Box

Terminal Box to IP54 as standard, protected against dust and water from any angle allowing outside applications.

Performance

The fan performance is in accordance with tests to BS848 Part 1 1980.

Sound Levels

Fan sound levels, measured in a reverberant chamber in accordance with BS848 Part 2 1985. Published dB(A) figures are free field sound pressure levels at 3m with spherical propagation at a reference level of 2×10^{-5} Pa (20 micro-Pascal). The sound power level spectra figures are dB with reference level of 10^{-12} Watts (1 pico-watt). To ensure minimum noise levels during speed control, an auto transformer speed control is recommended.

Accessories

A full range of accessories:

- Electronic Speed Controllers
- Auto Transformer Speed Controllers
- D.O.L. Starters & Overloads
- Ancillary Packs (comprising:- 4 AVM's, 2 mounting feet, 2 matching flanges, 2 flexible connectors + clips)
- Wire Guards
- Attenuators
- Mounting Feet
- Matching Flanges
- Anti Vibration Mounts
- Louvre Shutters

Dimensions (mm)

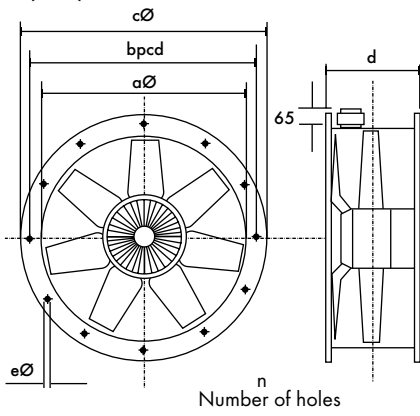

Dia	∅a	∅b	∅c	d	∅e	n	kg
250	254	286	306	110	7	8	5
315	316.5	356	382	135	9.5	8	6.1
355	356	395	421	135	9.5	8	7.1
400	400	438	466	155	9.5	12	8.1
450	451	487	515	160	9.5	12	13.4
500	503	541	567	166	9.5	12	15.7
560	559	605	635	210	11.5	16	20.1
630	634	674	707	220	11.5	16	44
710	711	751	785	260	11.5	16	31
800	797	837	871	280	11.5	24	39
1000	1001	1043	1080	330	11.5	24	73

Mounting Feet

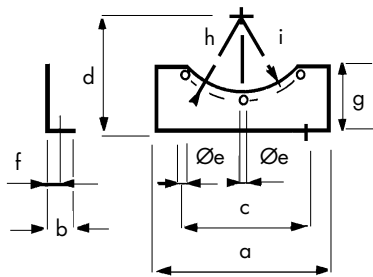

Stock Ref	a	b	c	d	∅e	f	g	h	i
MFZ315	315	40	265	200	10	20	71	178	166
MFZ355	350	40	300	225	10	20	81.5	198	186
MFZ400	250	40	220	250	10	20	78	219	205
MFZ450	275	40	240	275	10	20	82	244	230
MFZ500	315	50	280	315	1	25	100	271	255
MFZ560	355	50	320	355	12	25	97	303	285
MFZ630	400	50	360	400	12	25	109	337	320
MFZ710	465	50	415	450	12	25	119	376	362
MFZ800	458	50	420	518	12	25	176	419	405

Anti Vibration Mountings

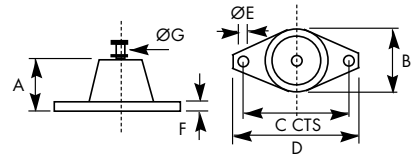

Stock Ref	A	B	C	D	∅E	F	∅G
68MP033G	27	37	54	67	7	3	M8

Coupling Flanges

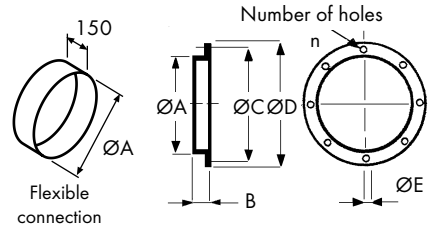

Stock Ref	∅A	B	∅C	∅D	∅E	n	Flexible Connection
CFZ315	313	40	356	382	10	8	FCZ315
CFZ355	353	40	395	421	10	8	FCZ355
CFZ400	398	45	438	466	10	12	FCZ400
CFZ450	448	45	487	515	10	12	FCZ450
CFZ500	498	45	541	567	10	12	FCZ500
CFZ560	558	45	605	635	12	16	FCZ560
CFZ630	628	45	674	707	12	16	FCZ630
CFZ710	708	50	751	785	12	16	FCZ710
CFZ800	798	50	837	871	12	24	FCZ800

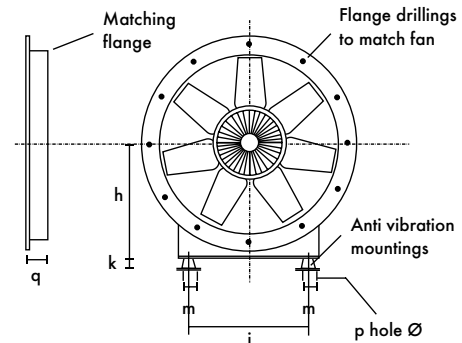

Unit size	h	i	k†	m	p∅	q
315	200	265	27	54	7	40
355	225	300	27	54	7	40
400	250	220	27	54	7	45
450	275	240	27	54	7	45
500	315	280	27	54	7	45
560	355	320	27	54	7	45
630	400	360	27	54	7	45
710	450	415	27	54	7	50
800	518	420	27	54	7	50

Performance Guide

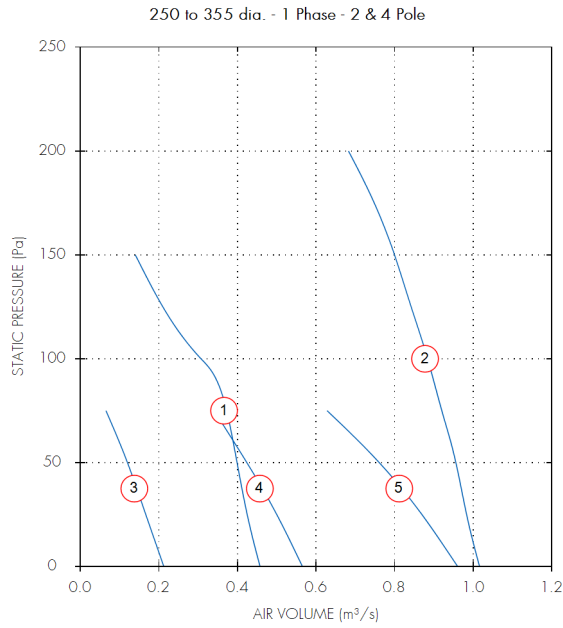

Dia.	Motor Phase	Stock Ref	Poles	r.p.m	IP Rating	Curve Ref.	m ³ /s @ Pa					Motor kW	S.C. Amps	F.L.C Amps	dB(A) @ 3m
							0	50	100	150	200				
250	1	ESC25012	2	2440	IP44	1	0.46	0.4	0.31	0.14		0.12	1.15	0.54	59
315	1	ESC31512	2	2690	IP54	2	1.02	0.96	0.88	0.8	0.68	0.56	7.2	2.4	64
250	1	ESC25014	4	1340	IP44	3	0.21	0.12				0.04	0.3	0.16	44
315	1	ESC31514	4	1300	IP54	4	0.57	0.42				0.15	1.38	0.7	50
355	1	ESC35514	4	1330	IP54	5	0.96	0.76				0.19	1.45	0.84	53

For Fans wired to reverse run, duty reduced by 30%
 ESC25012, ESC31512 and ESC25014 not suitable for reverse airflow

Sound Power Level Spectra dB (ref 10⁻¹² Watts)

Dia.	Motor Phase	Stock Ref	Poles	Spectrum	dB(A) @ 3m								
					63	125	250	500	1k	2k	4k	8k	
250	1	ESC25012	2	Inlet	69	70	76	76	70	70	67	59	57
250	1	ESC25012	2	Outlet	69	70	76	76	70	70	67	59	57
315	1	ESC31512	2	Inlet	69	73	79	74	74	76	73	66	61
315	1	ESC31512	2	Outlet	69	73	79	74	74	76	73	66	61
250	1	ESC25014	4	Inlet	70	72	63	58	54	52	45	35	41
250	1	ESC25014	4	Outlet	70	72	63	58	54	52	45	35	41
315	1	ESC31514	4	Inlet	70	68	66	61	60	62	58	51	47
315	1	ESC31514	4	Outlet	70	68	66	61	60	62	58	51	47
355	1	ESC35514	4	Inlet	65	70	67	65	64	64	62	55	50
355	1	ESC35514	4	Outlet	65	70	67	65	64	64	62	55	50

Performance Guide

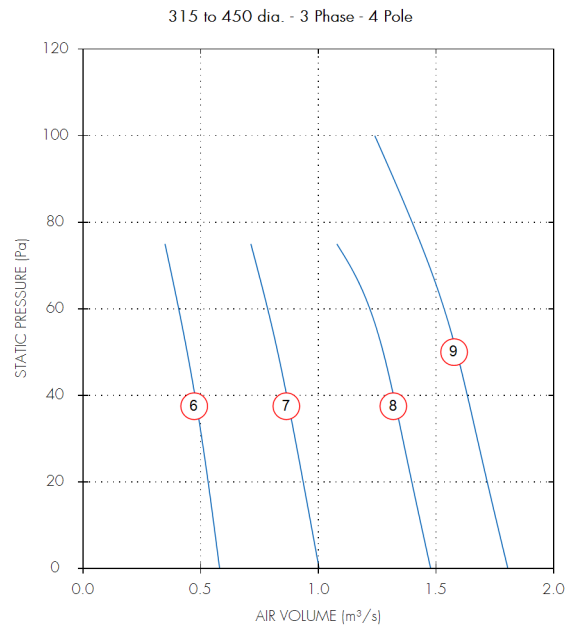
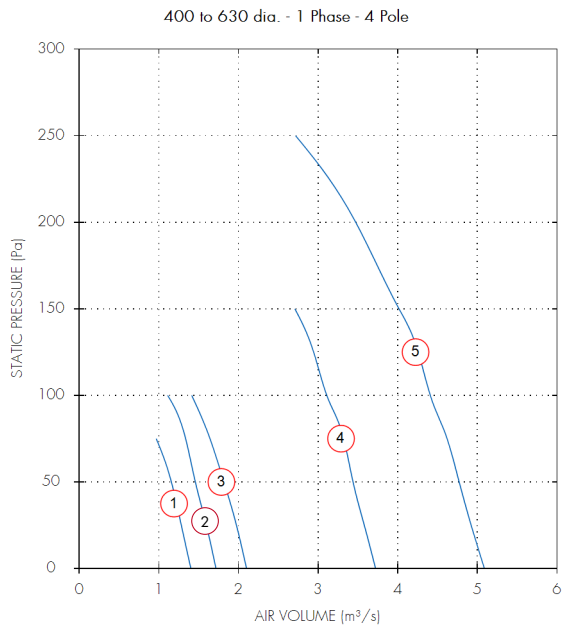

Dia.	Motor Phase	Stock Ref	Poles	r.p.m	IP Rating	Curve Ref.	m³/s @ Pa					Motor kW	S.C. Amps	F.L.C Amps	dB(A) @ 3m	
							0	50	100	150	200					250
400	1	ESC40014	4	1350	IP54	1	1.4	1.16					0.29	2.4	1.45	56
450	1	ESC45014	4	1370	IP54	2	1.72	1.46	1.11				0.36	3.6	1.6	61
500	1	ESC50014	4	1290	IP54	3	2.1	1.82	1.41				0.51	4.3	2.3	55
560	1	ESC56014	4	1320	IP54	4	3.72	3.44	3.11	2.71			1.4	9.3	6	63
630	1	ESC63014	4	1320	IP54	5	5.09	4.77	4.41	4.02	3.47	2.72	2.2	28	9.9	70
315	3	ESC31534	4	1390	IP54	6	0.58	0.44					0.11	2.1	0.27	46
355	3	ESC35534	4	1370	IP54	7	1	0.83					0.17	1.35	0.37	49
400	3	ESC40034	4	1350	IP54	8	1.48	1.27					0.26	2.1	0.56	51
450	3	ESC45034	4	1380	IP54	9	1.8	1.59	1.24				0.36	2.6	0.8	56

For Fans wired to reverse run, duty reduced by 30%

Sound Power Level Spectra dB (ref 10⁻¹² Watts)

Dia.	Motor Phase	Stock Ref	Poles	Spectrum	dB(A) @ 3m								
					63	125	250	500	1k	2k	4k	8k	
400	1	ESC40014	4	Inlet	70	72	67	66	65	65	64	56	51
400	1	ESC40014	4	Outlet	70	72	67	66	65	65	64	56	51
450	1	ESC45014	4	Inlet	69	76	73	72	70	71	70	62	57
450	1	ESC45014	4	Outlet	69	76	73	72	70	71	70	62	57
500	1	ESC50014	4	Inlet	65	75	69	70	70	71	69	62	56
500	1	ESC50014	4	Outlet	65	75	69	70	70	71	69	62	56
560	1	ESC56014	4	Inlet	100	90	89	84	82	79	75	68	67
560	1	ESC56014	4	Outlet	100	90	89	84	82	79	75	68	67
630	1	ESC63014	4	Inlet	82	86	79	79	80	78	75	70	64
630	1	ESC63014	4	Outlet	82	86	79	79	80	78	75	70	64
315	3	ESC31534	4	Inlet	64	67	69	63	62	60	58	53	47
315	3	ESC31534	4	Outlet	64	67	69	63	62	60	58	53	47
355	3	ESC35534	4	Inlet	58	73	63	64	64	65	64	58	50
355	3	ESC35534	4	Outlet	58	73	63	64	64	65	64	58	50
400	3	ESC40034	4	Inlet	62	73	65	65	67	69	67	60	53
400	3	ESC40034	4	Outlet	62	73	65	65	67	69	67	60	53
450	3	ESC45034	4	Inlet	65	82	75	76	73	72	69	62	58
450	3	ESC45034	4	Outlet	65	82	75	76	73	72	69	62	58

Performance Guide

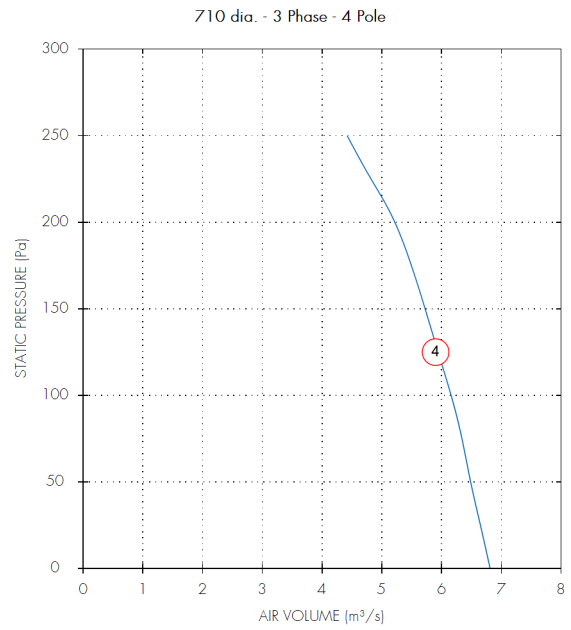
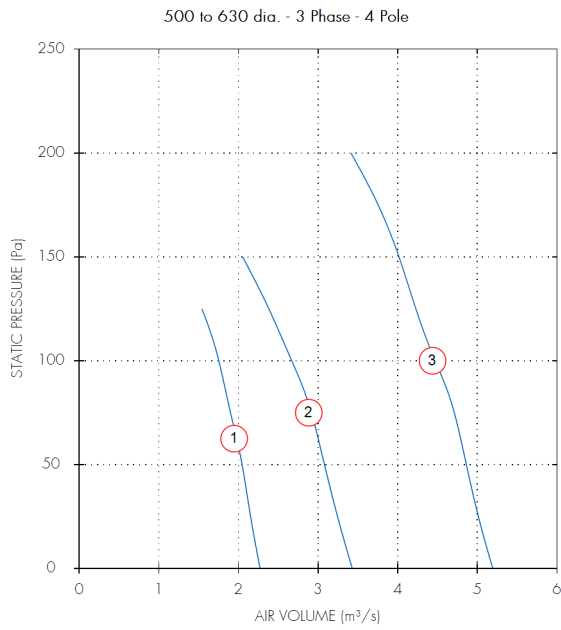

Dia.	Motor Phase	Stock Ref	Poles	r.p.m	IP Rating	Curve Ref.	m ³ /s @ Pa					Motor kW	S.C. Amps	F.L.C Amps	dB(A) @ 3m
							0	50	100	150	200				
500	3	ESC50034	4	1380	IP54	1	2.27	2.05	1.75			0.55	4.2	1.05	58
560	3	ESC56034	4	1220	IP54	2	3.43	3.08	2.67	2.05		1.25	7.7	2.2	70
630	3	ESC63034	4	1360	IP54	3	5.19	4.86	4.47	4.02	3.41	1.9	14	3.2	64
710	3	ESC71034	4	1290	IP54	4	6.81	6.49	6.16	5.72	5.22	2.9	19	5.3	72

For Fans wired to reverse run, duty reduced by 30%

Sound Power Level Spectra dB (ref 10⁻¹² Watts)

Dia.	Motor Phase	Stock Ref	Poles	Spectrum	dB(A) @ 3m								
					63	125	250	500	1k	2k	4k	8k	
500	3	ESC50034	4	Inlet	67	71	69	72	70	71	68	61	56
500	3	ESC50034	4	Outlet	67	71	69	72	70	71	68	61	56
560	3	ESC56034	4	Inlet	85	79	77	76	76	75	72	66	61
560	3	ESC56034	4	Outlet	85	79	77	76	76	75	72	66	61
630	3	ESC63034	4	Inlet	71	88	82	83	82	81	78	72	67
630	3	ESC63034	4	Outlet	71	88	82	83	82	81	78	72	67
710	3	ESC71034	4	Inlet	80	87	86	88	89	86	83	79	72
710	3	ESC71034	4	Outlet	80	87	86	88	89	86	83	79	72

Performance Guide

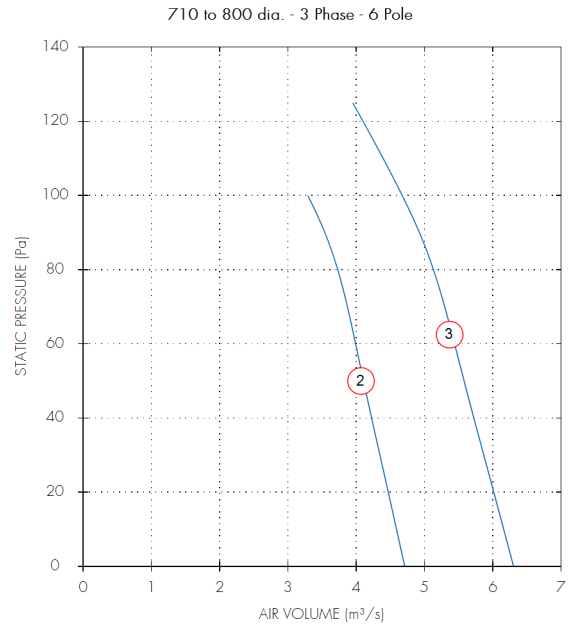
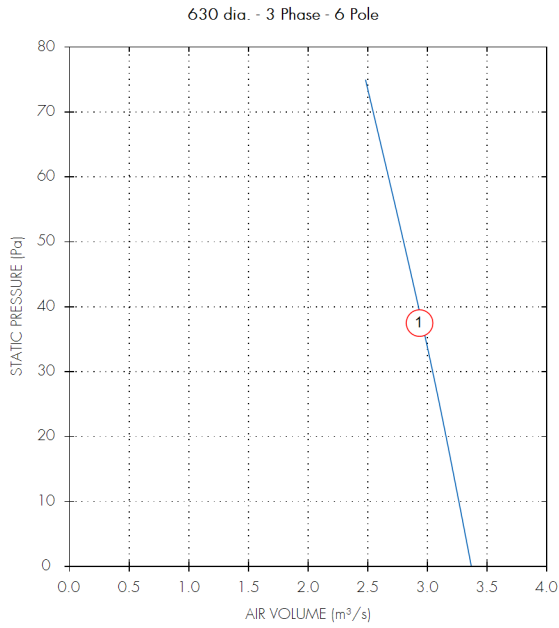

Dia.	Motor Phase	Stock Ref	Poles	r.p.m	IP Rating	Curve Ref.	m ³ /s @ Pa						Motor kW	S.C. Amps	F.L.C Amps	dB(A) @ 3m
							0	25	50	75	100	125				
630	3	ESC63036	6	890	IP54	1	3.37	3.1	2.8	2.48		0.59	3.6	1.3	59	
710	3	ESC71036	6	860	IP54	2	4.71	4.41	4.11	3.8	3.29	1.1	7.7	2.2	62	
800	3	ESC80036	6	900	IP54	3	6.3	5.94	5.58	5.22	4.67	1.4	9.8	2.7	64	

For Fans wired to reverse run, duty reduced by 30%

Sound Power Level Spectra dB (ref 10⁻¹² Watts)

Dia.	Motor Phase	Stock Ref	Poles	Spectrum	dB(A) @ 3m								
					63	125	250	500	1k	2k	4k	8k	
630	3	ESC63036	6	Inlet	67	78	76	74	73	72	77	59	60
630	3	ESC63036	6	Outlet	67	78	76	74	73	72	77	59	60
710	3	ESC71036	6	Inlet	80	77	78	75	76	75	70	64	60
710	3	ESC71036	6	Outlet	80	77	78	75	76	75	70	64	60
800	3	ESC80036	6	Inlet	75	75	73	71	72	70	64	57	56
800	3	ESC80036	6	Outlet	75	75	73	71	72	70	64	57	56

Models & Accessories

Fan Stock Ref	Speed Controller				Fan Stock Ref	Speed Controller	
	Electronic Stock Ref	Auto Transfor. Stock Ref	Starter Stock Ref	Overload Stock Ref		Auto Transfor. Stock Ref	
1 Phase 2 Pole					3 Phase 4 Pole		
ESC25012	SC5001	SPM5020	444744	444699			
ESC31512	SC5030TK	SPM5035	444744	444701	ESC31534	RDTK10	
1 Phase 4 Pole					ESC35534	RDTK10	
ESC25014	SC5001	SPM5020	444744	444696	ESC40034	RDTK10	
ESC31514	SC5001	SPM5020	444744	444699	ESC45034	RDTK10	
ESC35514	SC5030TK	SPM5020	444744	444699	ESC50034	RDTK20	
ESC40014	SC5030TK	SPM5020	444744	444701	ESC56034	RDTK40	
ESC45014	SC5030TK	SPM5035	444744	444701	ESC63034	RDTK40	
ESC50014	SC5030TK	SPM5035	444744	444702	ESC71034	RDTK70	
ESC56014	SC5010TK	SPM5075	444744	444704	3 Phase 6 Pole		
ESC63014	-	-	444744	444706	ESC63036	RDTK20	
					ESC71036	RDTK40	
					ESC80036	RDTK40	

*Not suitable for voltage speed control. Inverter speed control with sine filters only.

Size	1D Long - No Pod	1D Long - With Pod	2D Long - No Pod	2D Long - With Pod
	Stock Ref	Stock Ref	Stock Ref	Stock Ref
250	ACZ2501D	-	ACZ2502D	-
315	ACZ3151D	ACZ3151DP	ACZ3152D	ACZ3152DP
355	ACZ3551D	ACZ3551DP	ACZ3552D	ACZ3552DP
400	ACZ4001D	ACZ4001DP	ACZ4002D	ACZ4002DP
450	ACZ4501D	ACZ4501DP	ACZ4502D	ACZ4502DP
500	ACZ5001D	ACZ5001DP	ACZ5002D	ACZ5002DP
560	ACZ5601D	ACZ5601DP	ACZ5602D	ACZ5602DP
630	ACZ6301D	ACZ6301DP	ACZ6302D	ACZ6302DP
710	ACZ7101D	ACZ7101DP	ACZ7102D	ACZ7102DP
800	ACZ8001D	ACZ8001DP	ACZ8002D	ACZ8002DP

Starter Stock Ref	Overload Stock Ref	Ancillary Packs Stock Ref	Mounting Feet (pair) Stock Ref	Matching Flanges (each) Stock Ref	Wire Guards (each) Stock Ref	Anti-Vibration Mounts (set of 4) Stock Ref
444747	444699	APZ250	MFZ250	CFZ250	WGZ250	68MP033G
444747	444700	APZ315	MFZ315	CFZ315	WGZ315	68MP033G
		APZ250	MFZ250	CFZ250	WGZ250	68MP033G
444747	444697	APZ315	MFZ315	CFZ315	WGZ315	68MP033G
444747	444698	APZ355	MFZ355	CFZ355	WGZ355	68MP033G
444747	444699	APZ400	MFZ400	CFZ400	WGZ400	68MP033G
444747	444699	APZ450	MFZ450	CFZ450	WGZ450	68MP033G
444747	444700	APZ500	MFZ500	CFZ500	WGZ500	68MP033G
444747	444701	APZ560	MFZ560	CFZ560	WGZ560	68MP033G
444747	444702	APZ630	MFZ630	CFZ630	WGZ630	68MP033G
444747	444703	APZ710	MFZ710	CFZ710	WGZ710	68MP033G

- Note:
- The Standard roof cowl colour is BS 00A 05 (Goose Wing Grey) for all special B.S. or RAL colours contact Vent-Axia.
 - When speed control is required a 5 step auto transformer speed controller is recommended, to ensure low noise levels.
 - All 3 phase models are suitable for frequency inverter speed control.
 - Vent-Axia only recommends using inverters with integral sine filters for reliable operation.

EuroSeries[®] (ESR)

- Cowl & base moulded from recyclable polymeric material
- All sizes resistant to UV light
- Sizes 250 to 1000 dia are protected to IP54
- Optional backdraught shutters and bird guard (250-630mm)
- All models speed controllable
- Motor Insulation Class F, -40°C to +70°C operating temperature
- Reversible for supply or extract units
- Thermal overload for motor protection
- Performance tested to BS848 part 1 1980
- Designed for Data Centre and Warehouse cooling



A range of extract axial blade industrial roof fans incorporating the EuroSeries[®] ESP axial plate fan, featuring a single shot die cast aluminium blade & external rotor motor design.

Cowl and roof mounting base are moulded from specially formulated recyclable polymeric materials, which are high impact resistant and provide a rigid profile against strong winds and resistance to UV light. Standard colour BS00A05

EuroSeries[®] ESR units are suitable for flat or inclined roofs (max. angle 30°) and are designed for either kerb or purlin box mounting.

The EuroSeries[®] ESR range is available in eleven sizes with the extract performances up to 10.88m³/s, with pressure characteristics of up to 300Pa. All units are designed for & fully speed controllable.

Air Operated Shutters & Bird Guards

The shutters fits beneath the cowl using fitting provided. Shutters should not be used when the fan performance is below 30% of maximum and the hinge should point up the roof incline.

The standard shutters for sizes 800 & 1000mm must not be used with 4 & 6 pole unit. Please enquire for special metal shutters. Bird Guards are manufactured to fit neatly between the roof cowl and the base.

Impellers

All sizes are supplied with cast aluminium impellers, ensuring performance when working against outdoor conditions and abrasive airflow. All fans are reversible for Intake (approx 30% reduction in performance). Backdraught shutters should not be used when operated as an intake fan.

Motors

External rotor motors are specially designed and styled for this range of fan. Ball bearings are greased for life. Rotors are dynamically balanced to ISO 1940. Sizes 250-1000mm, motors are protected to IP54, against

dust and moisture complying with BS EN 60529:1992. They are ribbed aluminium body castings for efficient cooling. Motor insulation is Class 'F' (from -40°C to +70°C).

Electrical

Single phase 220-240V 50Hz. Capacitor start and run. Three phase 380-415V 50Hz. An IP54 terminal box is supplied with most models with 20mm and PGII entry. All motors are fitted with thermal overload protection which should be wired into all controller circuits and into starter contactors. Models are available with either 2, 4, 6 & 8 pole motors.

Terminal Box

Are to IP54, as standard, protected against dust and water from any angle allowing outside applications.

Performance

The fan performance is in accordance with tests to BS848 Part 1 1980.

Sound Levels

Fan sound levels, measured in a reverberant chamber in accordance with BS848 Part 2 1985. Published dB(A) figures are free field sound pressure levels at 3m with spherical propagation at a reference level of 2×10^{-5} Pa (20 micro-Pascal). The sound power level spectra figures are dB with reference level of 10^{-12} Watts (1 pico-watt). To ensure minimum noise levels during speed control, an auto transformer speed control is recommended.

Fan Dimensions (mm)

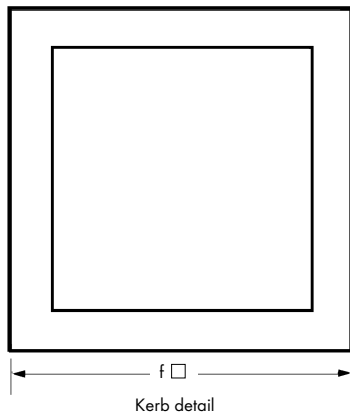
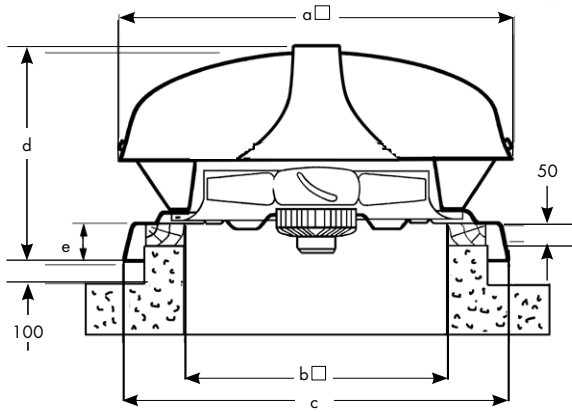

Purlin Box (mm)

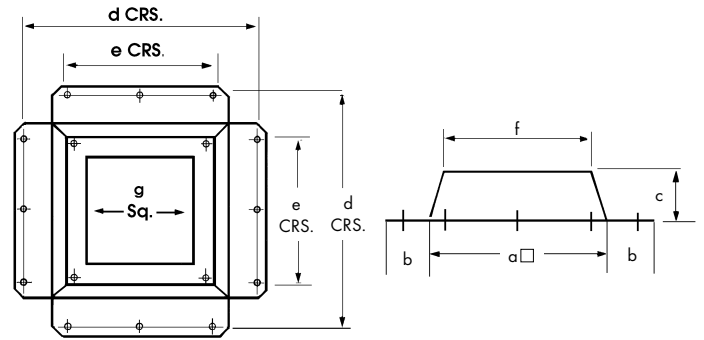

Size	a	b	c	d	e	f	g
250	625	90	240	765	400	590	460
315	625	90	240	765	400	590	460
355	625	90	240	765	400	590	460
400	725	90	240	865	500	705	565
450	725	90	240	865	500	705	565
500	890	70	250	990	650	850	640
560	890	70	250	990	650	870	700
630	1030	75	250	1140	760	985	775
710	1030	75	250	1140	760	985	840
800	980	37	267	1016	406	980	880
1000	1180	76	279	1294	508	1180	1080

Size	a	b	c	d	e	f	kg Max
250	700	475	737	411	97	675	13.25
315	700	475	737	411	97	675	16.3
355	700	475	737	411	97	675	16.3
400	800	575	830	466	97	775	18.4
450	800	575	830	466	97	775	20.3
500	950	715	1000	579	100	915	35.5
560	950	715	1000	579	100	915	35.5
630	1230	840	1100	731	105	1040	62
710	1230	840	1100	731	105	1040	62
800	1420	870	1190	731	105	1070	78
1000	1680	1070	1455	795	131	1270	134

Performance Guide

250 to 450 dia. - 1 Phase - 2 & 4 Pole

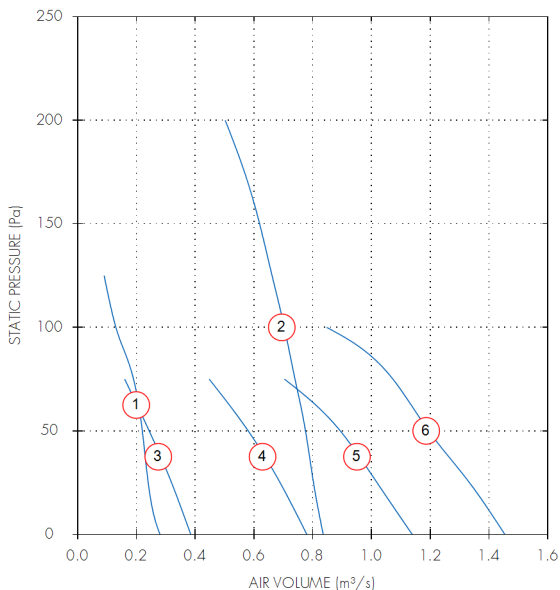

500 to 630 dia. - 1 Phase - 4 Pole

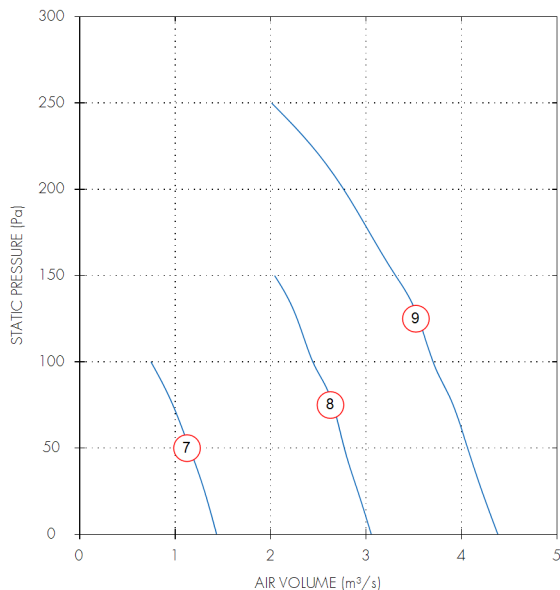

Dia.	Motor Phase	Stock Ref	Poles	r.p.m	IP Rating	Curve Ref.	m³/s @ Pa					Motor kW	S.C. Amps	F.L.C Amps	dB(A) @ 3m
							0	50	100	150	200				
250	1	ESR25012	2	2440	IP44	1	0.28	0.22	0.13			0.12	1.15	0.54	59
315	1	ESR31512	2	2690	IP54	2	0.84	0.78	0.7	0.62	0.5	0.56	7.2	2.4	64
315	1	ESR31514	4	1300	IP54	3	0.38	0.24				0.15	1.38	0.7	50
355	1	ESR35514	4	1330	IP54	4	0.78	0.58				0.19	1.45	0.84	53
400	1	ESR40014	4	1350	IP54	5	1.14	0.89				0.29	2.4	1.45	56
450	1	ESR45014	4	1370	IP54	6	1.45	1.19	0.85			0.36	3.6	1.6	61
500	1	ESR50014	4	1290	IP54	7	1.43	1.15	0.75			0.51	4.3	2.3	55
560	1	ESR56014	4	1320	IP54	8	3.05	2.77	2.44	2.04		1.35	21	6	63
630	1	ESR63014	4	1320	IP54	9	4.38	4.06	3.7	3.31	2.76	2.2	28	9.9	70

ESR25012, ESR31512 & ESR25014 not suitable for reverse airflow.

Sound Power Level Spectra dB (ref 10⁻¹² Watts)

Dia.	Motor Phase	Stock Ref	Poles	Spectrum	63	125	250	500	1k	2k	4k	8k	dB(A) @ 3m
250	1	ESR25012	2	Inlet	69	70	76	76	70	70	67	59	57
250	1	ESR25012	2	Outlet	69	70	76	76	70	70	67	59	57
315	1	ESR31512	2	Inlet	69	73	79	74	74	76	73	66	61
315	1	ESR31512	2	Outlet	69	73	79	74	74	76	73	66	61
315	1	ESR31514	4	Inlet	70	68	66	61	60	62	58	51	47
315	1	ESR31514	4	Outlet	70	68	66	61	60	62	58	51	47
355	1	ESR35514	4	Inlet	65	70	67	65	64	64	62	55	50
355	1	ESR35514	4	Outlet	65	70	67	65	64	64	62	55	50
400	1	ESR40014	4	Inlet	70	72	67	66	65	65	64	56	51
400	1	ESR40014	4	Outlet	70	72	67	66	65	65	64	56	51
450	1	ESR45014	4	Inlet	69	76	73	72	70	71	70	62	57
450	1	ESR45014	4	Outlet	69	76	73	72	70	71	70	62	57
500	1	ESR50014	4	Inlet	65	75	69	70	70	71	69	62	56
500	1	ESR50014	4	Outlet	65	75	69	70	70	71	69	62	56
560	1	ESR56014	4	Inlet	100	90	89	84	82	79	75	68	67
560	1	ESR56014	4	Outlet	100	90	89	84	82	79	75	68	67
630	1	ESR63014	4	Inlet	82	86	79	79	80	78	75	70	64
630	1	ESR63014	4	Outlet	82	86	79	79	80	78	75	70	64

Performance Guide

250 to 450 dia. - 3 Phase - 2 & 4 Pole

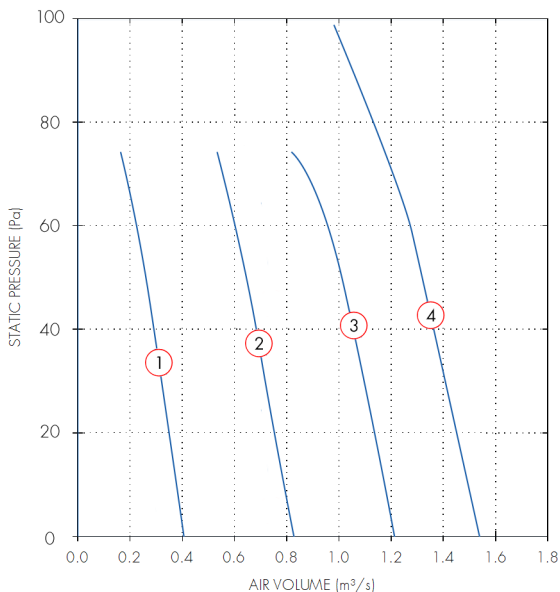

500 to 710 dia. - 3 Phase - 4 Pole

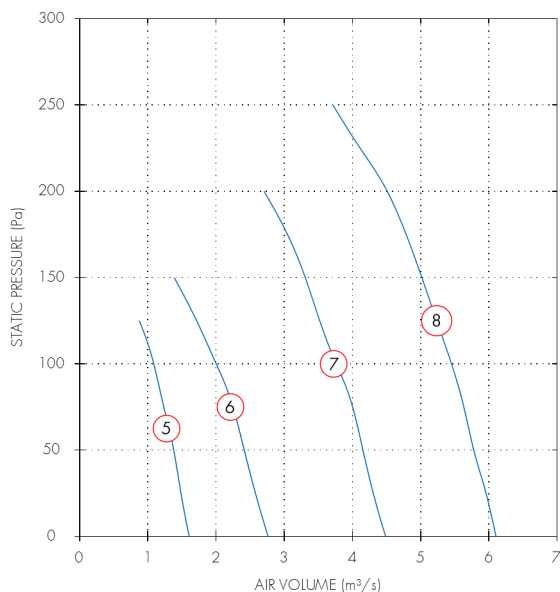

Dia.	Motor Phase	Stock Ref	Poles	r.p.m	IP Rating	Curve Ref.	m ³ /s @ Pa					Motor kW	S.C. Amps	F.L.C Amps	dB(A) @ 3m	
							0	50	100	150	200					250
315	3	ESR31534	4	1390	IP54	1	0.4	0.26				0.11	2.1	0.27	46	
355	3	ESR35534	4	1370	IP54	2	0.82	0.65				0.17	1.35	0.37	49	
400	3	ESR40034	4	1350	IP54	3	1.21	1.01				0.26	2.1	0.56	51	
450	3	ESR45034	4	1380	IP54	4	1.54	1.32	0.98			0.36	2.6	0.8	56	
500	3	ESR50034	4	1380	IP54	5	1.6	1.38	1.09			0.55	3.7	1.05	58	
560	3	ESR56034	4	1220	IP54	6	2.76	2.41	2	1.39		1.25	7.7	2.2	70	
630	3	ESR63034	4	1360	IP54	7	4.49	4.15	3.76	3.31	2.7	1.9	14	3.2	64	
710	3	ESR71034	4	1290	IP54	8	6.1	5.78	5.45	5.02	4.51	3.71	2.9	19	5.3	72

Sound Power Level Spectra dB (ref 10⁻¹² Watts)

Dia.	Motor Phase	Stock Ref	Poles	Spectrum	dB(A) @ 3m								
					63	125	250	500	1k	2k	4k	8k	
315	3	ESR31534	4	Inlet	64	67	69	63	62	60	58	53	47
315	3	ESR31534	4	Outlet	64	67	69	63	62	60	58	53	47
355	3	ESR35534	4	Inlet	58	73	63	64	64	65	64	58	50
355	3	ESR35534	4	Outlet	58	73	63	64	64	65	64	58	50
400	3	ESR40034	4	Inlet	62	73	65	65	67	69	67	60	53
400	3	ESR40034	4	Outlet	62	73	65	65	67	69	67	60	53
450	3	ESR45034	4	Inlet	65	82	75	76	73	72	69	62	58
450	3	ESR45034	4	Outlet	65	82	75	76	73	72	69	62	58
500	3	ESR50034	4	Inlet	67	71	69	72	70	71	68	61	56
500	3	ESR50034	4	Outlet	67	71	69	72	70	71	68	61	56
560	3	ESR56034	4	Inlet	85	79	77	76	76	75	72	66	61
560	3	ESR56034	4	Outlet	85	79	77	76	76	75	72	66	61
630	3	ESR63034	4	Inlet	71	88	82	83	82	81	78	72	67
630	3	ESR63034	4	Outlet	71	88	82	83	82	81	78	72	67
710	3	ESR71034	4	Inlet	80	87	86	88	89	86	83	79	72
710	3	ESR71034	4	Outlet	80	87	86	88	89	86	83	79	72

Performance Guide

315 to 710 dia. - 1 Phase - 6 Pole

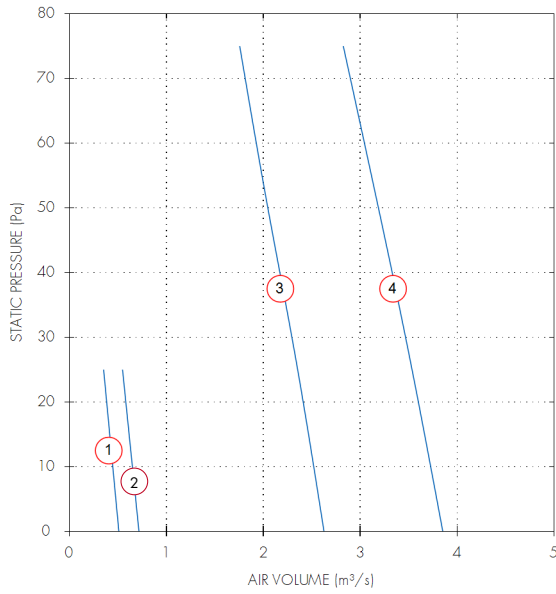

315 to 500 dia. - 3 Phase - 6 Pole

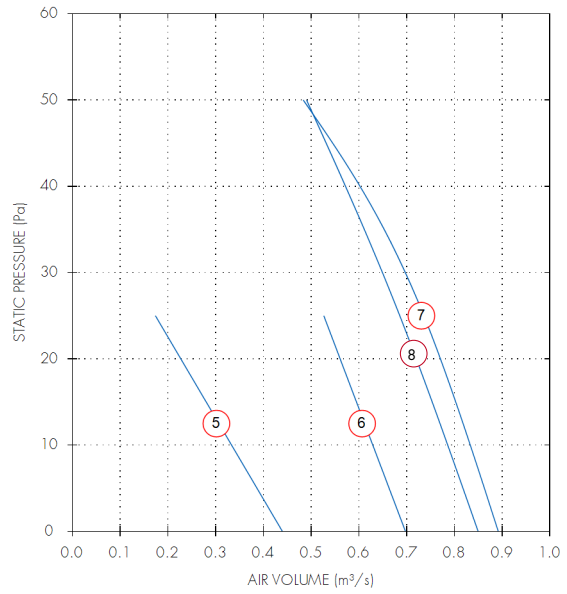

Dia.	Motor Phase	Stock Ref	Poles	r.p.m	IP Rating	Curve Ref.	m ³ /s @ Pa				Motor kW	S.C. Amps	F.L.C Amps	dB(A) @ 3m
							0	25	50	75				
355	1	ESR35516	6	950	IP54	1	0.51	0.35			0.09	1.2	0.46	44
400	1	ESR40016	6	940	IP54	2	0.72	0.55			0.13	1.4	0.6	45
630	1	ESR63016	6	880	IP54	3	2.63	2.35	2.05	1.76	0.6	5.3	2.7	57
710	1	ESR71016	6	850	IP54	4	3.85	3.53	3.19	2.82	0.89	8	4.1	60
355	3	ESR35536	6	910	IP54	5	0.44	0.17			0.09	0.5	0.25	45
400	3	ESR40036	6	920	IP54	6	0.7	0.53			0.11	0.9	0.28	50
450	3	ESR45036	6	890	IP54	7	0.89	0.74	0.48		0.12	1	0.28	51
500	3	ESR50036	6	900	IP54	8	0.85	0.69	0.49		0.23	1.5	0.56	56

Sound Power Level Spectra dB (ref 10⁻¹² Watts)

Dia.	Motor Phase	Stock Ref	Poles	Spectrum	dB(A) @ 3m								
					63	125	250	500	1k	2k	4k	8k	
355	1	ESR35516	6	Inlet	59	59	60	57	56	57	55	46	42
355	1	ESR35516	6	Outlet	59	59	60	57	56	57	55	46	42
400	1	ESR40016	6	Inlet	76	74	70	65	63	58	52	44	48
400	1	ESR40016	6	Outlet	76	74	70	65	63	58	52	44	48
630	1	ESR63016	6	Inlet	88	85	81	77	76	70	64	58	60
630	1	ESR63016	6	Outlet	88	85	81	77	76	70	64	58	60
710	1	ESR71016	6	Inlet	83	83	84	80	78	74	70	72	63
710	1	ESR71016	6	Outlet	83	83	84	80	78	74	70	72	63
355	3	ESR35536	6	Inlet	60	61	60	56	56	56	54	46	42
355	3	ESR35536	6	Outlet	60	61	60	56	56	56	54	46	42
400	3	ESR40036	6	Inlet	60	60	62	59	60	60	58	50	45
400	3	ESR40036	6	Outlet	60	60	62	59	60	60	58	50	45
450	3	ESR45036	6	Inlet	63	72	66	63	63	62	59	48	48
450	3	ESR45036	6	Outlet	63	72	66	63	63	62	59	48	48
500	3	ESR50036	6	Inlet	78	73	68	67	68	66	59	51	52
500	3	ESR50036	6	Outlet	78	73	68	67	68	66	59	51	52

Performance Guide

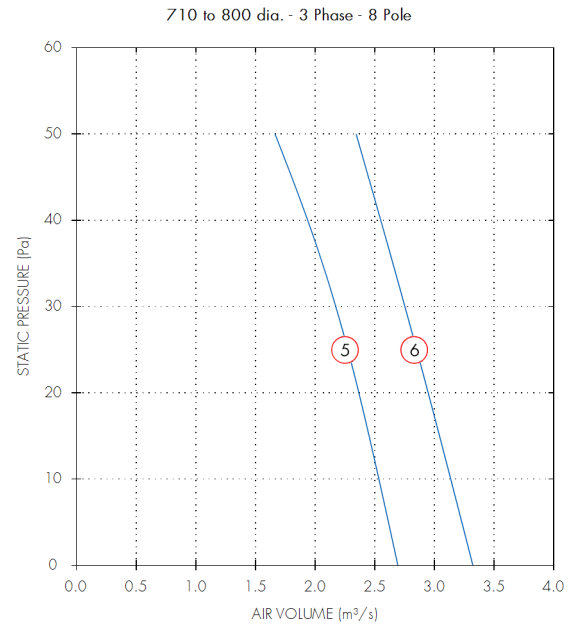
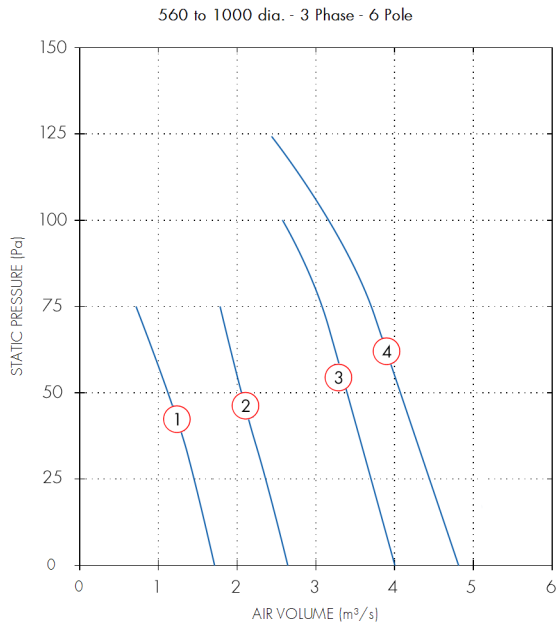

Dia.	Motor Phase	Stock Ref	Poles	r.p.m	IP Rating	Curve Ref.	m³/s @ Pa			Motor kW	S.C. Amps	F.L.C Amps	dB(A) @ 3m
							0	50	100				
560	3	ESR56036	6	860	IP54	1	1.72	1.16		0.36	1.75	0.74	56
630	3	ESR63036	6	890	IP54	2	2.66	2.07		0.59	3.6	1.3	59
710	3	ESR71036	6	860	IP54	3	4	3.4	2.58	1.1	7.7	2.2	62
800	3	ESR80036	6	900	IP54	4	4.81	4.08	3.18	1.4	7.7	2.2	64
710	3	ESR71038	8	630	IP54	5	2.69	1.66		0.43	3.3	1.1	55
800	3	ESR80038	8	670	IP54	6	3.32	2.34		0.69	5	1.75	58

Sound Power Level Spectra dB (ref 10⁻¹² Watts)

Dia.	Motor Phase	Stock Ref	Poles	Spectrum	dB(A) @ 3m								
					63	125	250	500	1k	2k	4k	8k	
560	3	ESR56036	6	Inlet	67	72	72	68	68	68	65	57	53
560	3	ESR56036	6	Outlet	67	72	72	68	68	68	65	57	53
630	3	ESR63036	6	Inlet	67	78	76	74	73	72	77	59	60
630	3	ESR63036	6	Outlet	67	78	76	74	73	72	77	59	60
710	3	ESR71036	6	Inlet	80	77	78	75	76	75	70	64	60
710	3	ESR71036	6	Outlet	80	77	78	75	76	75	70	64	60
800	3	ESR80036	6	Inlet	73	83	79	75	75	77	74	64	62
800	3	ESR80036	6	Outlet	73	83	79	75	75	77	74	64	62
710	3	ESR71038	8	Inlet	75	75	73	71	72	70	64	57	56
710	3	ESR71038	8	Outlet	75	75	73	71	72	70	64	57	56
800	3	ESR80038	8	Inlet	75	75	73	71	72	70	64	57	56
800	3	ESR80038	8	Outlet	75	75	73	71	72	70	64	57	56

Models & Accessories

Speed Controllers					
Fan Stock Ref	Electronic Stock Ref	Auto Transfor Stock Ref	Starter Stock Ref	Overload Stock Ref	Fan Stock Ref
1 Phase - 2 Pole					3 Phase - 4 Pole
ESR25012	SC5001	SPM5020	444744	444699	ESR31534
ESR31512	SC5030TK	SPM5035	444744	444701	ESR35534
1 Phase - 4 Pole					ESR40034
ESR25014	SC5001	SPM5020	444744	444696	ESR45034
ESR31514	SC5001	SPM5020	444744	444699	ESR50034
ESR35514	SC5030TK	SPM5020	444744	444699	ESR56034
ESR40014	SC5030TK	SPM5020	444744	444701	ESR63034
ESR45014	SC5030TK	SPM5020	444744	444701	ESR71034
ESR50014	SC5030TK	SPM5035	444744	444702	3 Phase - 6 Pole
ESR56014	SC5010TK	SPM5075	444744	444704	ESR35536
ESR63014	-	-	444744	444706	ESR40036
					ESR50036
1 Phase - 6 Pole					ESR56036
ESR35516	SC5030TK	SPM5020	444744	444698	ESR63036
ESR40016	SC5030TK	SPM5020	444744	444699	ESR71036
					ESR80036
					3 Phase - 6 Pole
ESR63016	SC5030TK	SPM5035	444744	444702	ESR63038
ESR71016	SC5050TK	SPM5060	444744	444703	ESR71038
					ESR80038

*Not suitable for voltage speed control. Inverter speed control with sine filters only.

Model Ref	Roof Cowl Assembly	Drop in Curb Attenuator		
	ONLY (No Fan) Stock Ref	(600mm) Stock Ref	(900mm) Stock Ref	(1200mm) Stock Ref
ESR250	-	RAZ300600	RAZ300900	-
ESR315 & 355	RCZ300	RAZ300600	RAZ300900	RAZ3001200
ESR400 & 450	RCZ400	RAZ400600	RAZ400900	RAZ4001200
ESR500 & 560	RCZ500	RAZ500600	RAZ500900	RAZ5001200
ESR630	RCZ630	RAZ600600	RAZ600900	RAZ6001200
ESR710	RCZ630	RAZ600600	RAZ600900	RAZ6001200
ESR800	RCZ800			
ESR1000	RCZ1000			

Speed Controllers

Speed Controllers						Adaptor Units (Purlin Box)
Auto Transfor Stock Ref	Starter Stock Ref	Overload Stock Ref	Shutters Stock Ref	Birdguard Stock Ref	Stock Ref	
RDTK10	444747	444699	RSZ300	BGZ300	PBZ300	
-	444747	444700	RSZ300	BGZ300	PBZ300	
			RSZ300	BGZ300	PBZ300	
RDTK10	444747	444697	RSZ300	BGZ300	PBZ300	
RDTK10	444747	444698	RSZ300	BGZ300	PBZ300	
RDTK10	444747	444699	RSZ400	BGZ400	PBZ400	
RDTK10	444747	444699	RSZ400	BGZ400	PBZ400	
RDTK20	444747	444700	RSZ500	BGZ500	PBZ500	
RDTK40	444747	444701	RSZ500	BGZ500	PBZ560	
RDTK40	444747	444702	RSZ630	BGZ630	PBZ630	
RDTK70	444747	444703	RSZ630	BGZ630	PBZ710	
RDTK10	444747	444697	RSZ300	BGZ300	PBZ300	
RDTK10	444747	444697	RSZ400	BGZ400	PBZ400	
RDTK10	444747	444699	RSZ500	BGZ500	PBZ500	
RDTK10	444747	444699	RSZ500	BGZ500	PBZ560	
RDTK20	444747	444700	RSZ630	BGZ630	PBZ630	
RDTK40	444747	444702	RSZ630	BGZ630	PBZ710	
RDTK40	444747	444702	-	INCL	PBZ800	
-	444748	444706	-	INCL	PBZ1000	
RDTK10	444747	444699	RSZ630	BGZ630	PBZ630	
RDTK20	444747	444700	RSZ630	BGZ630	PBZ710	
RDTK20	444747	444701	-	INCL	PBZ800	

Note:

- The Standard roof cowl colour is BS 00A 05 (Goose Wing Grey) for all special B.S. or RAL colours contact Vent-Axia.
- When speed control is required a 5 step auto transformer speed controller is recommended, to ensure low noise levels.
- All 3 phase models are suitable for frequency inverter speed control.
- Vent-Axia only recommend using inverters with integral sine filters for reliable operation.

Quiet Pack (QP)

- 'O' Class rated acoustically treated casing, ensuring minimum duct and breakout noise levels
- Air volumes up to 1.59m³/s
- Suitable for external pressures up to 500Pa
- Designed to suit duct diameters from 100 to 500mm
- Operating Temperatures from -15°C up to +40°C
- Speed Controllable
- Quality Assurance to BS EN ISO 9001:1994
- Performance tested to BS848 Part 1 1980

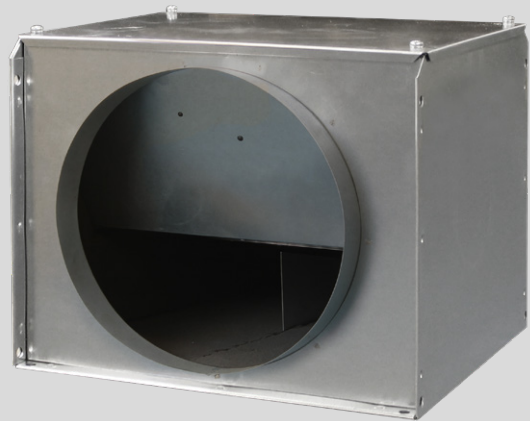

The Quiet Pack in-line acoustic fans are as supplied from Roof Units, designed around a high performance centrifugal impeller, offering a highly efficient, quiet and compact in-line acoustic fan.

The Quiet Pack fan range is manufactured from prime quality galvanised sheet steel, ensuring a robust in-line fan for those tough site conditions.

Quiet Pack casings are suitable for internal mounting and internally treated with an 'O' class rated acoustic foam, which offers the benefits of excellent low level duct bound and breakout sound levels, in addition self extinguishing properties, zero burn rate, resistant to ignition, and no toxic fumes.

Quiet Pack fans are suitable for circular ducting ranging in sizes 100, 125, 150, 160, 200, 250, 315, 400 and 500mm, with air volumes from 0.016m³/s to 1.8m³/s and pressure development of up to 500Pa.

The casing are specially designed to allow the unit to be mounted via drop rods or anti vibration mounts, ensuring a quick and easy solution to installation of the Quiet Pack in-line acoustic fans. All manufacturing processes of the Quiet Pack fan units are computer designed and controlled to BS EN ISO 9001 Standards.

Impellers

The motor and backward curved impeller is factory matched, statically and dynamically balanced on precision machines, to DIN ISO 1940 Grade 6.3, to give quiet, vibration free running.

Motors

Motor insulation Class B, suitable for operating temperatures from -15°C to +40°C and atmospheres up to 95% RH.

All sizes are ideally suitable for speed control by electronic or voltage reduction. Vent-Axia would recommend that a voltage reduction Auto Transformer speed controller is used with all Quiet Pack units to ensure minimum noise levels during speed control and to eliminate any possibility of harmonic noise levels which may occur when using electronic speed controllers at lower speeds.

Performance

The fan performance is in accordance with tests to BS848 Part 1 1980, with the fan sound levels measured in a reverberant chamber in accordance with BS848 Part 2 1985.

Quality Assurance

Design and manufacture is in accordance with the standard for quality management systems BS EN ISO 9001:1994.

Accessories

A full range of accessories are available with the Fan Box range of fans such as:

- Auto Transformer Speed Controllers
- Electronic Speed Controllers
- D.O.L. Starters
- Standard, Acoustic & Thermal Flexible Ducting
- Pre-Panel or Secondary Bag Filters
- Electric Heater Batteries
- Backdraught Shutters
- In-Line Attenuators
- Wall & Roof Terminals
- Fast Clamps

Dimensions (mm)

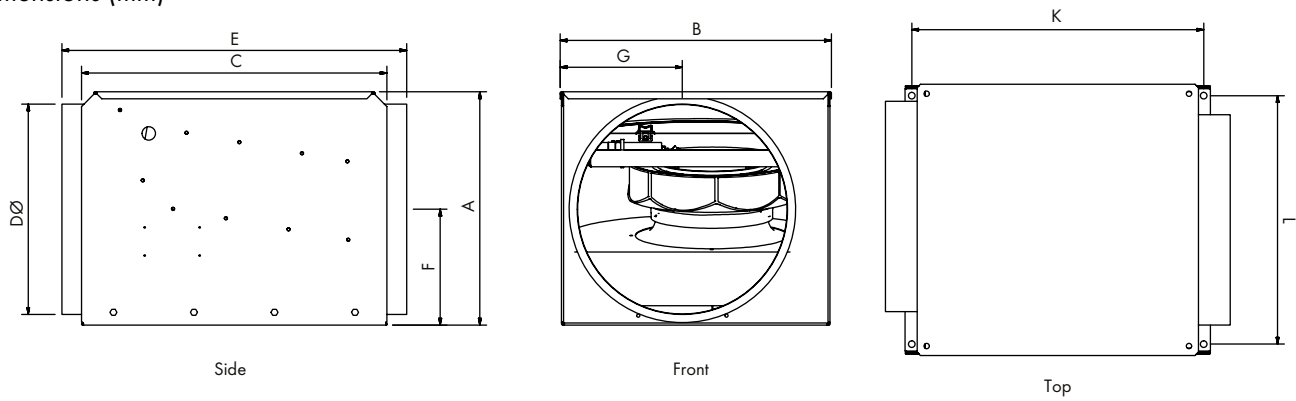

Stock Ref	A	B	C	ØD	E	F	G	K	L	kg
QP100C	190	310	400	100	460	94	111	380	275	11
QP125C	190	310	400	125	460	94	111	380	275	11
QP150C	190	310	400	150	460	94	111	380	275	11
QP160C	190	310	400	160	460	94	111	380	275	11
QP200C	285	364	455	200	515	141	127	435	330	17
QP250C	285	364	455	250	515	141	127	435	330	17
QP315C	456	572	730	315	792	227	243	710	540	45
QP400C	456	572	730	400	792	227	243	710	540	46
QP500C	575	769	918	500	1006	286	326	898	735	77

Anti Vibration Mountings

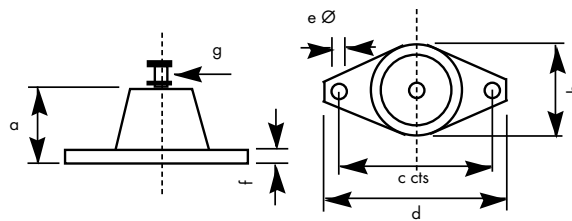

Stock Ref	a	b	c	d	eØ	f	g
68MP033G	27	37	54	67	7	3	M8

Performance Guide

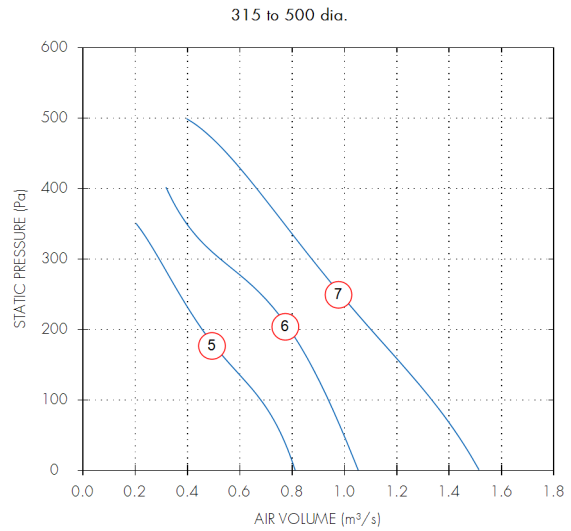
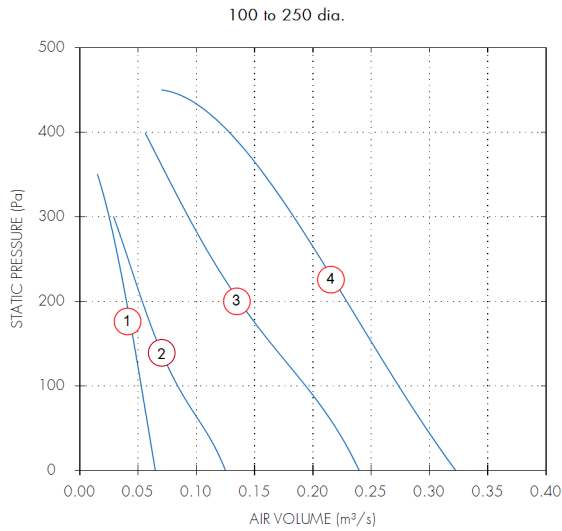

Dia.	Motor Phase	Stock Ref	r.p.m	Curve Ref.	m³/s @ Pa					Motor kW	S.C. Amps	F.L.C Amps	dB(A) @ 3m
					0	100	200	300	400				
100	1	QP100C	2350	1	0.06	0.05	0.04	0.03		0.05	0.37	0.23	32
125	1	QP125C	2350	1	0.07	0.05	0.04	0.02		0.05	0.37	0.23	33
150	1	QP150C	2350	2	0.12	0.08	0.05	0.03		0.05	0.37	0.23	33
150	1	QP160C	2350	2	0.12	0.08	0.05	0.03		0.05	0.37	0.23	33
200	1	QP200C	2700	3	0.24	0.19	0.14	0.09		0.09	0.85	0.38	36
250	1	QP250C	2500	4	0.32	0.27	0.23	0.18	0.13	0.16	1.25	0.68	36
315	1	QP315C	1330	5	0.81	0.68	0.46	0.29		0.27	2.2	1.18	38
400	1	QP400C	1340	6	1.05	0.94	0.79	0.53	0.32	0.47	5.9	2.33	39
500	1	QP500C	1330	7	1.52	1.33	1.1	0.88	0.66	0.73	6.27	3.21	47

Sound Power Level Spectra dB (ref 10⁻¹² Watts)

Dia.	Motor Phase	Stock Ref	Spectrum	dB(A) @ 3m								
				63	125	250	500	1k	2k	4k	8k	
100	1	QP100C	Inlet	53	59	68	58	50	45	34	33	41
100	1	QP100C	Outlet	54	57	63	59	60	54	49	42	43
100	1	QP100C	Breakout	48	52	59	49	41	39	31	32	32
125	1	QP125C	Inlet	51	65	73	62	51	46	36	36	45
125	1	QP125C	Outlet	52	62	67	64	62	55	52	45	46
125	1	QP125C	Breakout	51	53	60	49	41	40	33	33	33
150	1	QP150C	Inlet	54	60	70	59	52	46	38	36	42
150	1	QP150C	Outlet	56	58	63	58	59	56	49	43	43
150	1	QP150C	Breakout	50	55	60	50	43	38	31	32	33
160	1	QP160C	Inlet	54	60	70	59	52	46	38	36	42
160	1	QP160C	Outlet	56	58	63	58	59	56	49	43	43
160	1	QP160C	Breakout	50	55	60	50	43	38	31	32	33
200	1	QP200C	Inlet	60	65	63	68	58	55	54	46	46
200	1	QP200C	Outlet	60	63	68	72	68	67	62	53	53
200	1	QP200C	Breakout	54	58	60	57	46	41	35	34	36
250	1	QP250C	Inlet	64	74	72	67	57	55	56	53	48
250	1	QP250C	Outlet	64	74	75	69	70	71	65	64	56
250	1	QP250C	Breakout	52	57	68	52	44	40	36	38	39
315	1	QP315C	Inlet	66	78	68	60	52	49	42	40	45
315	1	QP315C	Outlet	67	75	77	71	69	62	56	49	53
315	1	QP315C	Breakout	54	70	63	53	47	41	35	34	38
400	1	QP400C	Inlet	73	82	79	68	62	55	50	49	52
400	1	QP400C	Outlet	72	78	78	75	74	66	58	53	57
400	1	QP400C	Breakout	57	71	63	56	51	46	39	35	39
500	1	QP500C	Inlet	77	85	78	71	64	62	54	52	54
500	1	QP500C	Outlet	74	83	82	78	77	72	64	58	61
500	1	QP500C	Breakout	68	81	72	63	56	49	42	41	48

Models & Accessories

Fan Stock Ref	Speed Controller				Anti Vibration Mounts (set of 4) Stock Ref
	Electronic	Auto	Starter	Overload	
	Stock Ref	Transfor.	Stock Ref	Stock Ref	
QP100C	SC5001	SPM5020	444744	444699	68MP033G
QP125C	SC5001	SPM5020	444744	444699	68MP033G
QP150C	SC5001	SPM5020	444744	444699	68MP033G
QP160C	SC5001	SPM5020	444744	444699	68MP033G
QP200C	SC5001	SPM5020	444744	444699	68MP033G
QP250C	SC5001	SPM5020	444744	444699	68MP033G
QP315C	SC5030	SPM5035	444744	444699	68MP033G
QP400C	SC5050TK	SPM5035	444744	444699	68MP033G
QP500C	SC5050TK	SPM5060	444744	444171	68MP033G

Fan Stock Ref	Electric			
	Heaters Stock Ref	Panel Filters Stock Ref	Bag Filters Stock Ref	
QP100C	10531100T1	QPF100A	QPFB100A	
QP125C	10531125T1	QPF125A	QPFB125A	
QP150C	10531150T1	QPF150A	QPFB150A	
QP160C	-	QPF160A	QPFB160A	
QP205C	10531200T1	QPF200A	QPFB200A	
QP250C	10531250T1	QPF250A	QPFB250A	
QP315C	10531315T1	QPF315A	QPFB315A	
QP400C	10531400T3	QPF400A	QPFB400A	
QP500C	10531500T3	QPF500A	QPFB500A	

Fan Stock Ref	In-line Attenuators				Wall Terminal Stock Ref
	300mm Stock Ref	600mm Stock Ref	900mm Stock Ref	1200mm Stock Ref	
QP100C	83010030	83010060	83010090	-	SA100/280
QP125C	83012030	83012060	83012090	-	SA125/280
QP150C	83015030	83015060	83015090	-	SA150/280
QP160C	83016030	83016060	83016090	-	SA150/280
QP205C	-	83020060	83020090	83020120	SA200/280
QP250C	-	83025060	83025090	83025120	SA250/280
QP315C	-	83031060	83031090	83031120	SA315/280
QP400C	-	-	83040090	83040120	QSA400/280
QP500C	-	-	83050090	83050120	-

Quiet Pack Twin Fan (QPTW)

- Air volumes up to 1.07m³/s
- Suitable for external pressures up to 450Pa
- Designed to suit duct diameters from 100 to 400mm
- Operating temperatures up to 40°C
- Speed controllable
- Quality assurance to BS EN ISO 9001:1994
- Performance tested to BS848 Part 1 1980



The Quiet Pack Twin in-line fans are as supplied from Roof Units, designed around a high performance centrifugal impeller, offering a highly efficient, quiet and compact twin in-line acoustic fan.

The Quiet Pack Twin fan range is manufactured from prime quality galvanised sheet steel, ensuring a robust twin in-line fan for those tough site conditions.

Casings are suitable for internal mounting only and internally treated with an 'O' class rated acoustic foam, which offers the benefits of excellent low level duct bound and breakout sound levels, in addition self extinguishing properties, zero burn rate, resistant to ignition, and no toxic fumes.

Quiet Pack Twin fans are suitable for circular ducting ranging in sizes 100, 125, 150, 160, 250, 315 and 400 with air volumes up to 1.07m³/s and pressure development of up to 450Pa.

They are specially designed to allow the unit to be mounted via drop rods or anti vibration mounts, ensuring a quick and easy solution to installation with all units fitted with backdraught shutters to prevent air flow returning back through the system during shutdown periods.

Impellers

The motor and backward curved impeller is factory matched, statically and dynamically balanced on precision machines, to ISO 1940 Grade 6.3., to give quiet, vibration free running.

Motors

Motor insulation Class B, suitable for operating temperatures from -15°C up to +40°C and atmospheres up to 95% RH.

All sizes are suitable for speed control by electronic or voltage reduction. Vent-Axia would recommend that a voltage reduction Auto Transformer speed controller is used with all units to ensure minimum noise levels during speed control and to eliminate any possibility of harmonic noise levels which may occur when using electronic speed controllers at lower speeds.

Performance

The fan performance is in accordance with tests to BS848 Part 1 1980, with the fan sound levels measured in a reverberant chamber in accordance with BS848 Part 2 1985.

Quality Assurance

Design and manufacture is in accordance with the standard for quality management systems BS EN ISO 9001:1994.

Accessories

A full range of accessories are available to complement the range of fans such as:

- Manual/Auto Changeover Twin Fan Controllers
- Auto Transformer Speed Controllers
- D.O.L. Starters
- Standard, Acoustic & Thermal Flexible Ducting
- In-Line Attenuators
- Wall & Roof Terminals
- Fast Clamps

ACOB1A Twin Fan Controller



IP rating: IP40.
Fuse Size: T rated 15 amp glass fuse (5x20mm).

Models
Stock Ref
ACOB1A

- Manual or auto changeover facilities
- 2 to 24 hour adjustable duty sharing
- Diagnostic program facility on start up
- Suitable for 1 phase twin fan units up to 8 amps
- Can be wired in conjunction with speed controllers
- Volt free contacts fitted as standard
- Neon failure indicators

Specification

Supply Voltage: 230 to 240V/1ph/50Hz.
Maximum Current Capacity: 0.1 to 8.0 amps.
Operating temperature: 0°C to +40°C.

Dimensions (mm)

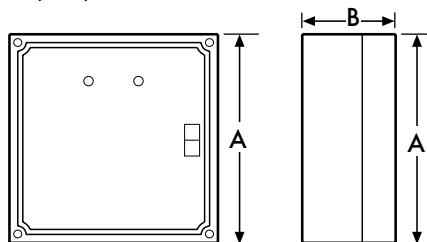

Size	A	B	kg
ACOB1A	125	56	0.28

Dimensions (mm)

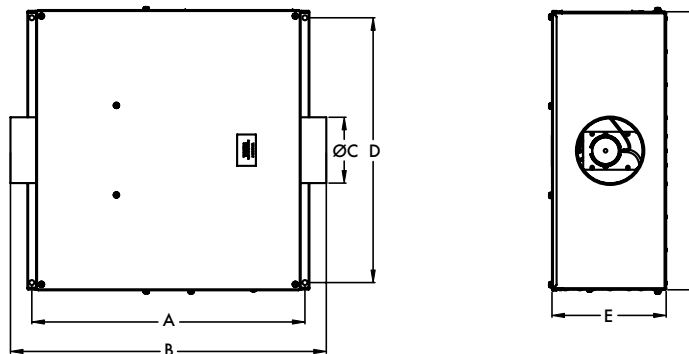

Stock Ref	Duct Diameter mm				Weight		
	A	B	ØC	D			
QPTW100C	610	705	100	591	256	622	26
QPTW125C	610	705	125	591	256	622	26
QPTW150C	610	705	150	591	256	622	26
QPTW250C	925	1020	250	798	354	829	48
QPTW315C	1255	1353	315	1145	536	1176	88
QPTW400C	1255	1353	400	1145	536	1176	90

Anti Vibration Mountings

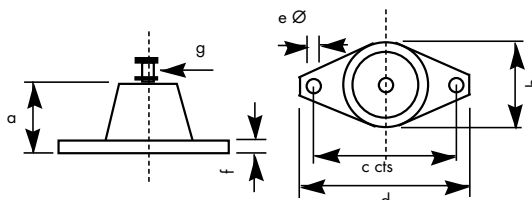

Stock ref	a	b	c	d	eØ	f	g
68MP033G	27	37	54	67	7	3	M8

Performance Guide

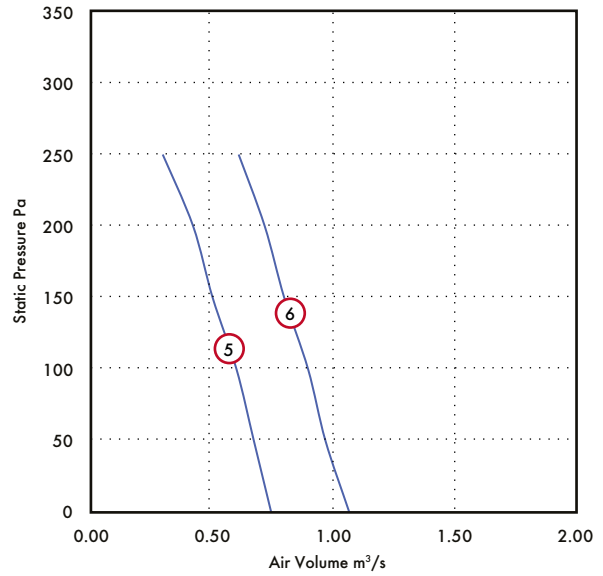
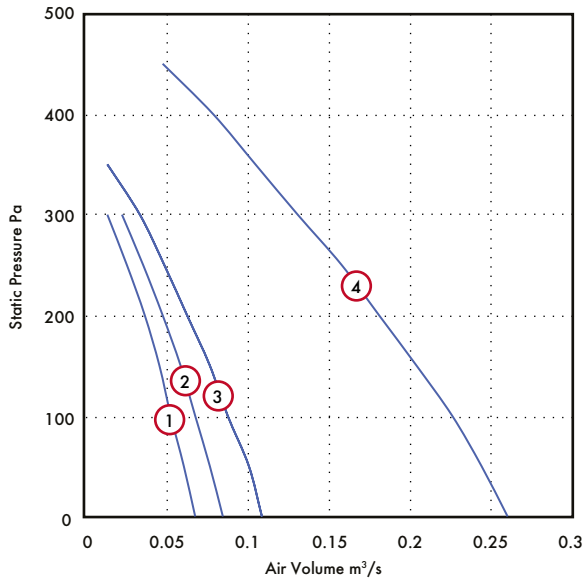

Stock Ref	rpm	Phase	Curve Ref	Duty m³/s @ Pa										Motor kW	S.C. Amps	F.L.C. Amps	dB(A) @ 3m	
				0	50	100	150	200	250	300	350	400	450					
QPTW100C	2450	1	1	0.068	0.061	0.053	0.046	0.037	0.026	0.014					0.05	0.37	0.23	32
QPTW125C	2450	1	2	0.085	0.077	0.068	0.059	0.048	0.036	0.023					0.05	0.37	0.23	33
QPTW150C	2450	1	3	0.109	0.101	0.088	0.077	0.063	0.049	0.034	0.014				0.05	0.37	0.23	33
QPTW160C	2700	1	3	0.109	0.101	0.088	0.077	0.063	0.049	0.034	0.014				0.05	0.37	0.23	33
QPTW250C	2550	1	4	0.260	0.244	0.226	0.204	0.181	0.158	0.131	0.105	0.079	0.048		0.16	1.25	0.68	36
QPTW315C	1330	1	5	0.747	0.675	0.603	0.504	0.423	0.297						0.27	2.2	1.18	38
QPTW400C	1340	1	6	1.071	0.972	0.9	0.801	0.72	0.612						0.47	5.9	2.33	39

FLC = Full Load Current SC = Starting Current

Sound Power Level Spectra dB (ref 10⁻¹² Watts)

Dia.	Motor Phase	Stock Ref	Spectrum	63	125	250	500	1k	2k	4k	8k	dB(A) @ 3m
100	1	QPTW100C	Inlet	53	59	68	58	50	45	34	33	41
100	1	QPTW100C	Outlet	54	57	63	59	60	54	49	42	43
100	1	QPTW100C	Breakout	48	52	59	49	41	39	31	32	32
125	1	QPTW125C	Inlet	51	65	73	62	51	46	36	36	45
125	1	QPTW125C	Outlet	52	62	67	64	62	55	52	45	46
125	1	QPTW125C	Breakout	51	53	60	49	41	40	33	33	33
150	1	QPTW150C	Inlet	54	60	70	59	52	46	38	36	42
150	1	QPTW150C	Outlet	56	58	63	58	59	56	49	43	43
150	1	QPTW150C	Breakout	50	55	60	50	43	38	31	32	33
160	1	QPTW160C	Inlet	54	60	70	59	52	46	38	36	42
160	1	QPTW160C	Outlet	56	58	63	58	59	56	49	43	43
160	1	QPTW160C	Breakout	50	55	60	50	43	38	31	32	33
250	1	QPTW250C	Inlet	64	74	72	67	57	55	56	53	48
250	1	QPTW250C	Outlet	64	74	75	69	70	71	65	64	56
250	1	QPTW250C	Breakout	52	57	68	52	44	40	36	38	39
315	1	QPTW315C	Inlet	66	78	68	60	52	49	42	40	45
315	1	QPTW315C	Outlet	67	75	77	71	69	62	56	49	53
315	1	QPTW315C	Breakout	54	70	63	53	47	41	35	34	38
400	1	QPTW400C	Inlet	73	82	79	68	62	55	50	49	52
400	1	QPTW400C	Outlet	72	78	78	75	74	66	58	53	57
400	1	QPTW400C	Breakout	57	71	63	56	51	46	39	35	39

Models & Accessories

Fan Stock Ref	Auto Changeover Controller Stock Ref	Auto Transformer Stock Ref	In-line Attenuators			
			300mm Stock Ref	600mm Stock Ref	900mm Stock Ref	1200mm Stock Ref
QPTW100C	ACOB1A	SPM5020	83010030	83010060	83010090	-
QPTW125C	ACOB1A	SPM5020	83012030	83012060	83012090	-
QPTW150C	ACOB1A	SPM5020	83015030	83015060	83015090	-
QPTW160C	ACOB1A	SPM5020	-	83016060	83016090	-
QPTW250C	ACOB1A	SPM5035	-	83025060	83025090	83025120
QPTW315C	ACOB1A	SPM5060	-	83031060	83031090	83031120
QPTW400C	ACOB1A	SPM5060	-	-	83040090	83040120

Fan Stock Ref	Anti Vibration Mounts Stock Ref	Intumescent Fire Dampers Stock Ref	Wall Terminal Stock Ref	Roof Terminal Stock Ref
QPTW125C	68MP033G	CVT130	SA125/280	WB160
QPTW150C	68MP033G	CVT150	SA150/280	WB160
QPTW160C	68MP033G	-	SA150/280	WB200
QPTW250C	68MP033G	CVT250	SA250/280	WB200
QPTW315C	68MP033G	CVT300	SA315/280	RCZ300
QPTW400C	68MP033G	-	QSA400/280	RCZ400

Slimpak EC Box Fan (SLP EC)

- Ultra slim and compact
- Energy efficient EC/DC motor
- Backward curved impeller
- Acoustically treated 'O' class rated
- 'Eco Flow' computer modelled design
- Integral commissioning potentiometer
- Optional external speed control input
- Matching ancillaries



The Slimpak EC single in-line box fans incorporate an energy efficient EC motor and basic commissioning controls to offer an energy efficient basic fan system.

Manufactured from Galvanised sheet the Slimpak (SLP EC) fan units are internally treated with an 'O' class rated, BS476 part 6 & 7, acoustic foam, which offers the benefits of high sound absorption and good thermal insulation properties, in addition to self extinguishing properties and resistance to ignition.

The casing includes an inclined inlet and bellmouth entry which directs the incoming air to the impeller with minimal turbulence. The result is better air management through the unit, less noise, higher efficiency and an increased performance.

The housing is designed to be as compact as possible for ceiling or plant room applications with integral mounting points to allow quick and easy installation.

Motor / Impellers

All SLP EC units feature an energy efficient, Class 1, EC/DC external rotor motor and backward curved impeller assembly specifically chosen for performance and non-overloading characteristics. The assembly is dynamically balanced to DIN ISO 1940 Grade 6.3, duct size 500mm rated IP54, all other sizes, IP44 according to BS EN 60529. Ball bearings are greased for life. Insulation is Class 'B' (from -25°C to +60°C). All models incorporate internal electronic overload protection and soft start function.

Control

Every SLP EC unit is fitted with a purpose designed integral commissioning controller giving the ability to set the exact duty required at commissioning. Alternatively the integral potentiometer can be bypassed to allow remote speed control via an external 0-10V potentiometer. Low voltage control wiring is kept separate from the mains wiring.

Electrical

Motors are single phase 230V +/- 10% / 50/60Hz / 1ph (size 100-400mm) or 400V +/- 10% / 50/60Hz / 3ph (size 500mm).

Performance/Sound

Extensively tested to BS848 parts 1 & 2. Published dB(A) figures are free field sound pressure levels at 3m with spherical propagation at reference level of 2 x 10⁻⁵ Pa. The inlet/outlet sound power level spectra figures are dB with a reference of 10-12 watts.

Quality Assurance

Design and manufacture are in accordance with the standard for quality management systems BS EN ISO 9001:1994.

Accessories

A full range of accessories are available with the Slimpak EC range of fans such as:

- Remote potentiometer speed controller
 - Two speed trickle boost controller
 - Pre & secondary filter cassettes
 - Electric heater batteries
 - Backdraught shutters
 - In-line attenuators
-

Dimensions (mm)

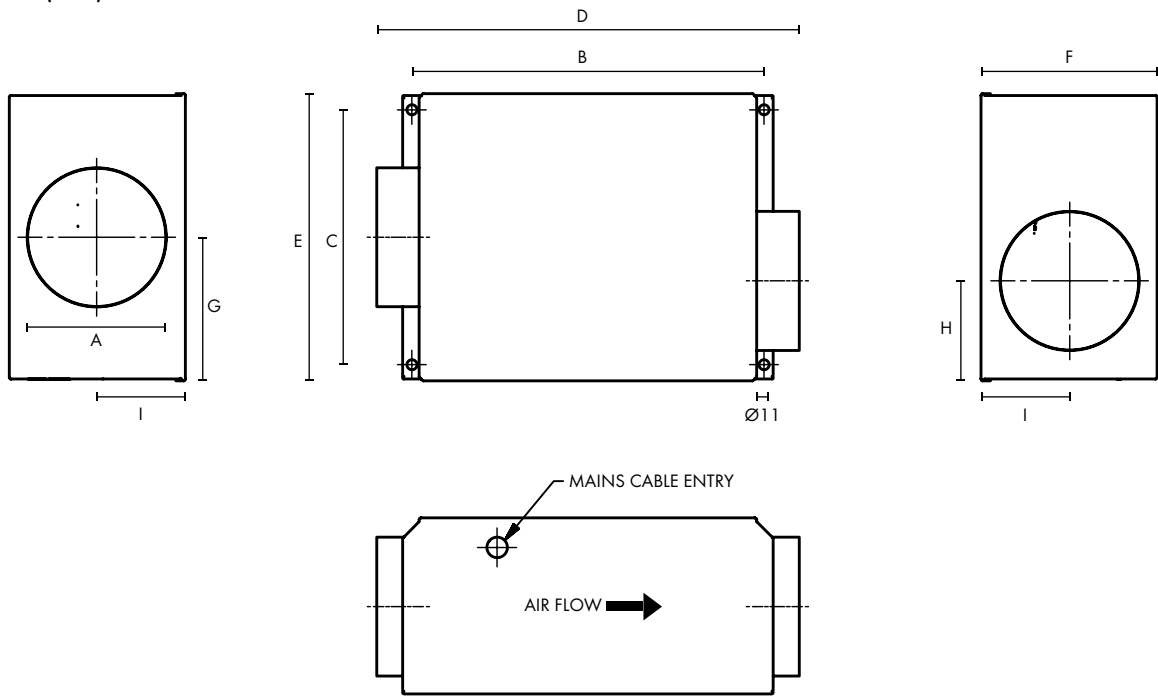

Stock Ref	A	B	C	D	E	F	G	H	I	kg
SLP100EC	100	380	275	456	310	192	155	108	96	7.5
SLP125EC	125	380	275	456	310	192	155	108	96	7.5
SLP150EC	150	380	275	456	310	192	155	108	96	7.5
SLP200EC	200	435	330	511	364	287	182	122	143	12
SLP250EC	250	435	330	511	364	287	182	122	143	13
SLP315EC	315	710	540	785	572	460	286	243	230	33
SLP400EC	400	710	540	785	572	460	286	243	230	36
SLP500EC	500	898	735	975	770	577	385	326	286	58

Performance Guide

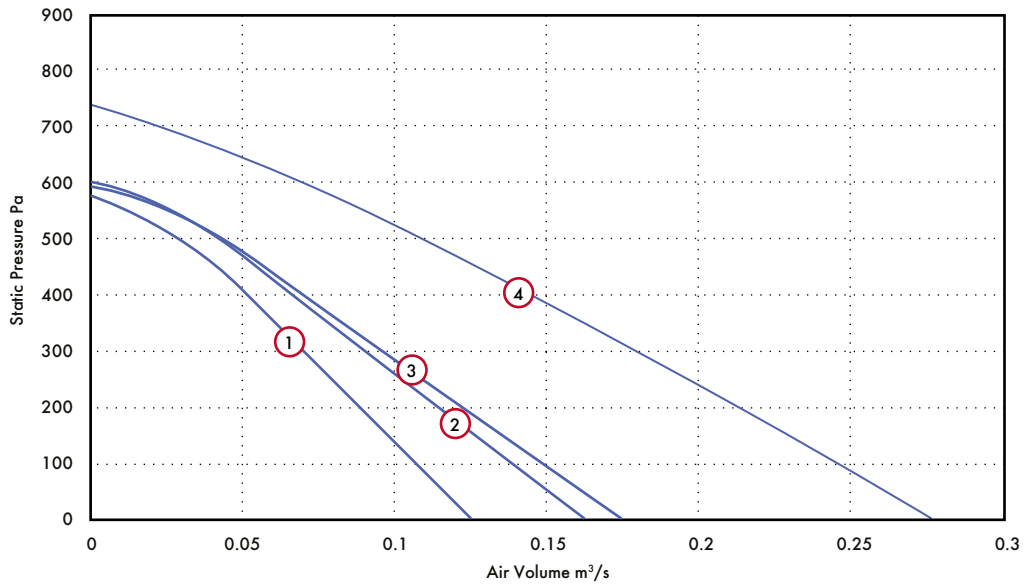

Dia.	Motor Phase	Stock Ref	IP Rating	Curve Ref.	m ³ /s @ Pa								S.C. Amps	F.L.C Amps	dB(A) @ 3m			
					0	100	200	300	400	500	600	700						
100	1	SLP100EC	IPX2	1	m ³ /s	0.13	0.11	0.09	0.07	0.05	0.03							
					kW	0.08	0.08	0.08	0.08	0.08	0.08				0.72	0.72	36	
					W/l/s	0.64	0.76	0.92	1.15	1.54	2.69							
125	1	SLP125EC	IPX2	2	m ³ /s	0.16	0.14	0.11	0.09	0.07	0.04							
					kW	0.08	0.08	0.08	0.08	0.08	0.08				0.72	0.72	37	
					W/l/s	0.50	0.58	0.72	0.92	1.24	1.95							
150	1	SLP150EC	IPX2	3	m ³ /s	0.17	0.15	0.12	0.10	0.07	0.04							
					kW	0.08	0.08	0.08	0.08	0.08	0.08				0.74	0.74	39	
					W/l/s	0.46	0.54	0.66	0.85	1.17	1.94							
200	1	SLP200EC	IPX2	4	m ³ /s	0.28	0.25	0.21	0.18	0.14	0.11	0.07	0.02					
					kW	0.15	0.16	0.17	0.17	0.17	0.17	0.17	0.16			0.72	0.72	42
					W/l/s	0.55	0.66	0.78	0.94	1.17	1.57	2.47	8.21					

Sound Power Level Spectra dB (ref 10⁻¹² Watts)

Dia.	Motor Phase	Stock Ref	Spectrum	dB(A) @ 3m								
				63	125	250	500	1k	2k	4k	8k	
100	1	SLP100EC	Inlet	57	62	68	71	58	52	47	41	48
			Outlet	57	63	71	72	66	62	55	48	51
			Breakout	64	63	60	55	47	46	44	38	36
125	1	SLP125EC	Inlet	58	69	70	70	60	56	48	42	48
			Outlet	58	70	71	73	70	67	60	52	54
			Breakout	62	58	59	57	52	46	37	33	37
150	1	SLP150EC	Inlet	59	68	72	76	64	58	51	48	53
			Outlet	59	70	74	76	71	70	64	58	57
			Breakout	62	61	59	60	54	49	43	37	39
200	1	SLP200EC	Inlet	68	71	72	77	70	63	61	57	56
			Outlet	70	72	69	80	76	76	72	65	62
			Breakout	63	69	66	60	53	51	50	50	42

Performance Guide

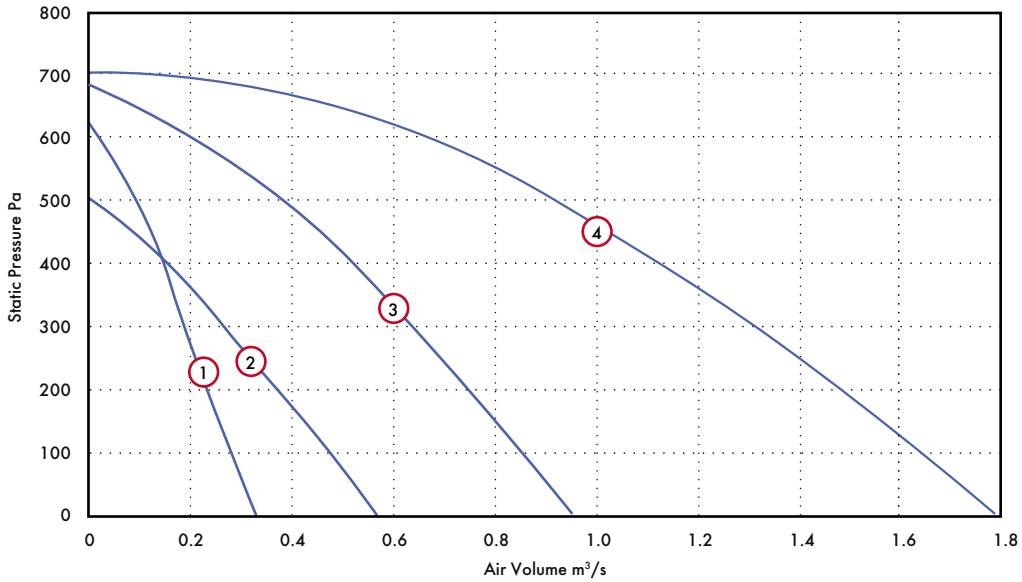

Dia.	Motor Phase	Stock Ref	IP Rating	Curve Ref.	m³/s @ Pa							S.C. Amps	F.L.C Amps	dB(A) @ 3m	
					0	100	200	300	400	500	600				
250	1	SLP250EC	IP44	1	m³/s	0.33	0.28	0.24	0.19	0.15	0.09	1.38	1.38	42	
					kW	0.12	0.14	0.14	0.15	0.14	0.13				
					W/l/s	0.38	0.48	0.61	0.76	0.99	1.47				
315	1	SLP315EC	IP44	2	m³/s	0.57	0.48	0.37	0.26	0.15	1.36	1.36	44		
					kW	0.15	0.16	0.16	0.16	0.16					
					W/l/s	0.27	0.34	0.44	0.62	1.07					
400	1	SLP400EC	IP44	3	m³/s	0.95	0.85	0.75	0.64	0.52	0.38	0.20	2.47	2.47	48
					kW	0.40	0.42	0.44	0.44	0.44	0.42	0.36			
					W/l/s	0.42	0.49	0.58	0.69	0.84	1.09	1.83			
500	3	SLP500EC	IP54	4	m³/s	1.79	1.63	1.47	1.31	1.13	0.93	0.67	2.1	2.1	49
					kW	0.68	0.78	0.86	0.92	0.95	0.94	0.88			
					W/l/s	0.38	0.48	0.58	0.70	0.84	1.02	1.31			

Sound Power Level Spectra dB (ref 10⁻¹² Watts)

Dia.	Motor Phase	Stock Ref	Spectrum	63	125	250	500	1k	2k	4k	8k	dB(A) @ 3m
250	1	SLP250EC	Inlet	68	71	72	80	68	62	59	56	57
			Outlet	68	71	70	78	75	75	68	63	60
			Breakout	61	63	62	62	55	54	52	45	42
315	1	SLP315EC	Inlet	67	78	79	66	61	58	53	45	52
			Outlet	66	78	78	73	70	68	63	55	56
			Breakout	62	69	69	56	53	47	43	36	42
400	1	SLP400EC	Inlet	78	83	87	73	69	66	61	54	59
			Outlet	78	85	92	80	79	75	69	61	66
			Breakout	67	73	76	63	58	50	44	40	48
500	3	SLP500EC	Inlet	88	93	86	80	71	67	59	53	62
			Outlet	87	91	89	84	83	78	68	62	67
			Breakout	74	80	76	67	61	54	44	36	50

Models & Accessories



Fan Stock Ref	Remote Speed Control Stock Ref	Trickle/Boost Controller Stock Ref
SLP100EC	10520602	475775
SLP125EC	10520602	475775
SLP150EC	10520602	475775
SLP200EC	10520602	475775
SLP250EC	10520602	475775
SLP315EC	10520602	475775
SLP400EC	10520602	475775
SLP500EC	10520602	475775



Backdraught
Shutter
Stock Ref



Fast
Clamp
Stock Ref



Anti-Vibration
Mounts (set of 4)
Stock Ref

Size	Backdraught Shutter Stock Ref	Fast Clamp Stock Ref	Anti-Vibration Mounts (set of 4) Stock Ref
100	10542100	10540100	68MP033G
125	10542125	10540125	68MP033G
150	10542150	10540150	68MP033G
200	10542200	10540200	68MP033G
250	10542250	10540250	68MP033G
315	10542315	10540315	68MP033G
400	10542400	10540400	68MP033G
500	-	-	68MP033G



Duct Attenuator

Size	300mm Stock Ref	600mm Stock Ref	900mm Stock Ref	1200mm Stock Ref
100	10534100	10535100	10536100	-
125	10534125	10535125	10536125	-
150	10534150	10535150	10536150	-
200	-	10535200	10536200	10537200
250	-	10535250	10536250	10537250
315	-	10535315	10536315	10537315
400	-	10535400	10536400	10537400
500	-	-	10536500	-

Models & Accessories



Size	Duct Air Heater Stock Ref	Filter Cassette Stock Ref	Bag Filter Cassette Stock Ref	Flexible Connections Stock Ref
100	10531100T1	10532100	10533100	FLX100
125	10531125T1	10532125	10533125	FLX125
150	10531150T1	10532150	10533150	FLX150
200	10531200T1	10532200	10533200	FLX200
250	10531250T1	10532250	10533250	FLX250
315	10531315T1 10531315T3	10532315	10533315	FLX315
400	10531400T3	10532400	10533400	FLX400
500	10531500T3	10532500A	10533500	FLX500

Slimpak EC Box Fan (SLPT EC)

- Compact low profile design
- Duct Sizes 100 - 500mm
- Performance - Airflow 0.01 to 1.2m³/s, Pressure up to 650Pa
- Latest energy saving EC/DC motors
- Internal mounting IPX2
- Manufactured controlled to BS EN ISO 9001
- Performance tested to BS848 Part 1 & 2

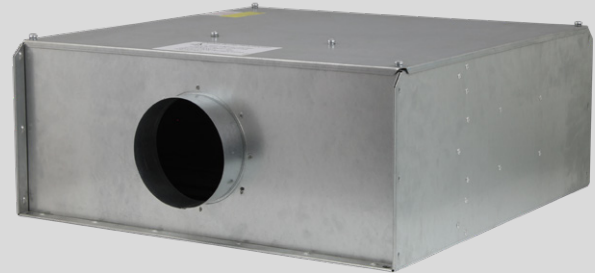

The Slimpak EC twin in-line duct fans incorporate energy efficient EC motors and basic commissioning controls to offer an energy efficient twin extract fan system.

Manufactured from prime quality galvanised sheet steel the Slimpak (SLPT EC) twin fan units are internally treated with an 'O' class rated, BS476 part 6 & 7, acoustic foam, which offers the benefits of high sound absorption, good thermal insulation properties in addition to self extinguishing properties and resistant to ignition.

The housing is designed to be as compact as possible for concealed false ceiling applications yet is suitable for ceiling or floor mounting, non-return dampers can be easily rotated on site to suit the application.

Motor / Impellers

All SLPT EC units feature a low energy, Class 1, EC/DC external rotor motor and backward curved impeller assembly specifically chosen for performance and non-overloading characteristics. The assembly is dynamically balanced to DIN ISO 1940 Grade 6.3, duct size 500mm rated IP54, all other sizes, IP44 according to BS EN 60529. Ball bearings are greased for life. Insulation is Class 'B' (from -25°C to +60°C).

All models incorporate internal electronic overload protection and soft start function.

Electrical

Every SLPT EC unit is fitted with a purpose designed common integral commissioning controller giving the ability to set the exact duty required at commissioning. Alternatively the integral potentiometer can be bypassed to allow remote speed control via an external 0-10V potentiometer. Low voltage wiring is kept separate from the mains wiring.

Electrical

Motors are single phase 230V +/- 10% / 50/60Hz / 1ph (size 100-400mm) or 400V +/- 10% / 50/60Hz / 3ph (size 500mm), (4 wire systems only).

Performance/Sound

Extensively tested to BS848 parts 1 & 2. Published dB(A) figures are free field sound pressure levels at 3m with spherical propagation at reference level of 2x10⁻⁵ Pa. The inlet/outlet sound power level spectra figures are dB with a reference of 10-12 watts.

Quality Assurance

Design and manufacture are in accordance with the standard for quality management systems BS EN ISO 9001:1994.

Accessories

A full range of accessories are available with the Slimpak EC range of fans such as:

- Auto changeover controller designed for EC motors
 - Two speed trickle boost controller
 - Pre & secondary filter cassettes
 - Electric heater batteries
 - Backdraught shutters
 - In-line attenuators
-

Dimensions (mm)

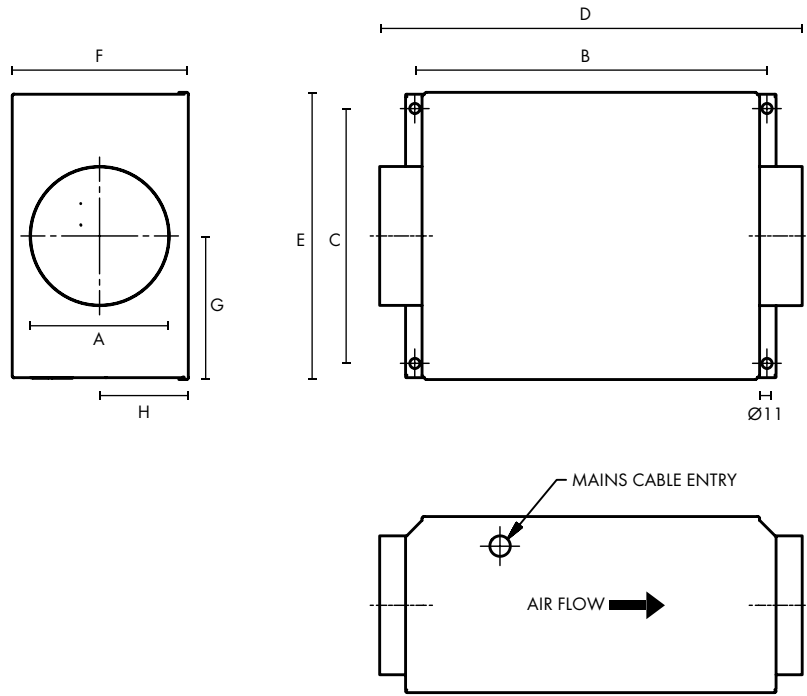

Stock Ref	A	B	C	D	E	F	G	H	kg
SLPT100EC	100	610	591	705	622	256	311	128	26
SLPT125EC	125	610	591	705	622	256	311	128	26
SLPT150EC	150	610	591	705	622	256	311	128	26
SLPT200EC	200	801	703	896	734	343	367	172	39
SLPT250EC	250	925	798	1020	829	354	415	177	48
SLPT315EC	315	1255	1145	1353	1176	536	588	268	88
SLPT400EC	400	1255	1145	1353	1176	536	588	268	90
SLPT500EC	500	1492	1533	1590	1564	675	782	338	175

Performance Guide

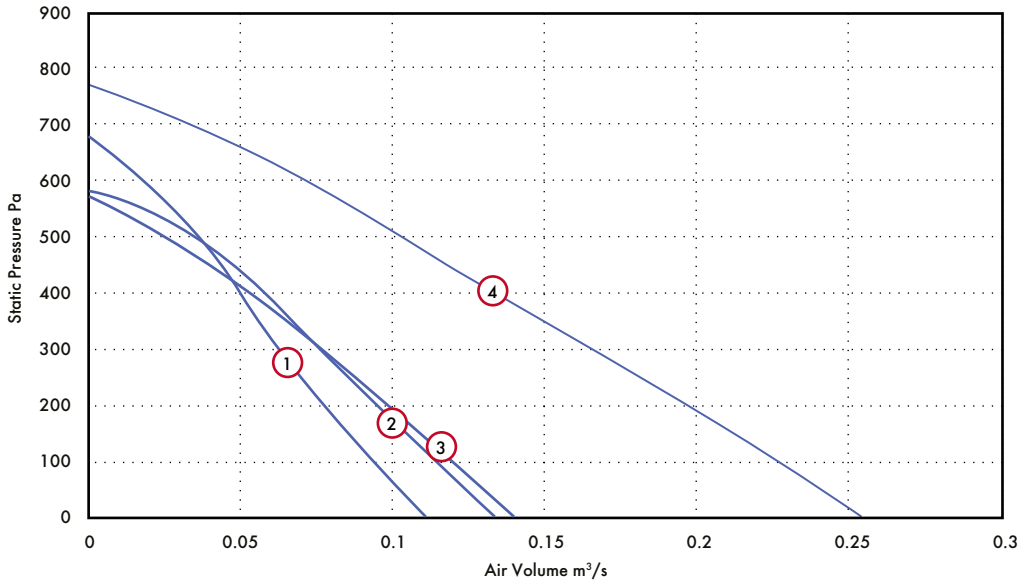

Dia.	Motor Phase	Stock Ref	IP Rating	Curve Ref.	m³/s @ Pa								S.C. Amps	F.L.C Amps	dB(A) @ 3m	
					0	100	200	300	400	500	600	700				
100	1	SLPT100EC	IP44	1	m³/s	0.11	0.09	0.08	0.06	0.05	0.04	0.02	0.69	0.69	36	
					kW	0.08	0.08	0.08	0.08	0.08	0.08	0.08				
					W/l/s	0.74	0.89	1.09	1.34	1.70	2.35	4.40				
125	1	SLPT125EC	IP44	2	m³/s	0.13	0.11	0.09	0.08	0.06	0.03	0.72	0.72	39		
					kW	0.08	0.08	0.08	0.08	0.08	0.08					
					W/l/s	0.61	0.72	0.87	1.08	1.42	2.24					
150	1	SLPT150EC	IP44	3	m³/s	0.14	0.12	0.10	0.08	0.05	0.02	0.71	0.71	39		
					kW	0.08	0.08	0.08	0.08	0.08	0.08					
					W/l/s	0.58	0.70	0.84	1.07	1.54	3.09					
200	1	SLPT200EC	IP44	4	m³/s	0.25	0.23	0.20	0.17	0.13	0.10	0.07	0.04	1.4	1.4	42
					kW	0.16	0.17	0.17	0.17	0.17	0.17	0.17	0.16			
					W/l/s	0.63	0.72	0.84	1.01	1.26	1.64	2.34	4.37			

Sound Power Level Spectra dB (ref 10⁻¹² Watts)

Dia.	Motor Phase	Stock Ref	Spectrum	dB(A) @ 3m								
				63	125	250	500	1k	2k	4k	8k	
100	1	SLPT100EC	Inlet	55	63	56	53	49	45	38	34	35
			Outlet	53	65	59	58	54	55	48	39	40
			Breakout	65	69	61	50	42	40	37	36	36
125	1	SLPT125EC	Inlet	52	66	66	56	51	47	38	39	40
			Outlet	54	69	64	61	57	57	52	43	43
			Breakout	59	72	64	52	41	36	35	36	39
150	1	SLPT150EC	Inlet	58	66	66	59	50	46	39	36	40
			Outlet	60	71	67	64	61	61	55	49	47
			Breakout	60	63	62	59	51	47	42	41	39
200	1	SLPT200EC	Inlet	58	70	63	68	62	55	51	49	47
			Outlet	68	75	65	80	67	67	64	60	58
			Breakout	67	69	64	63	51	45	38	40	42

Performance Guide

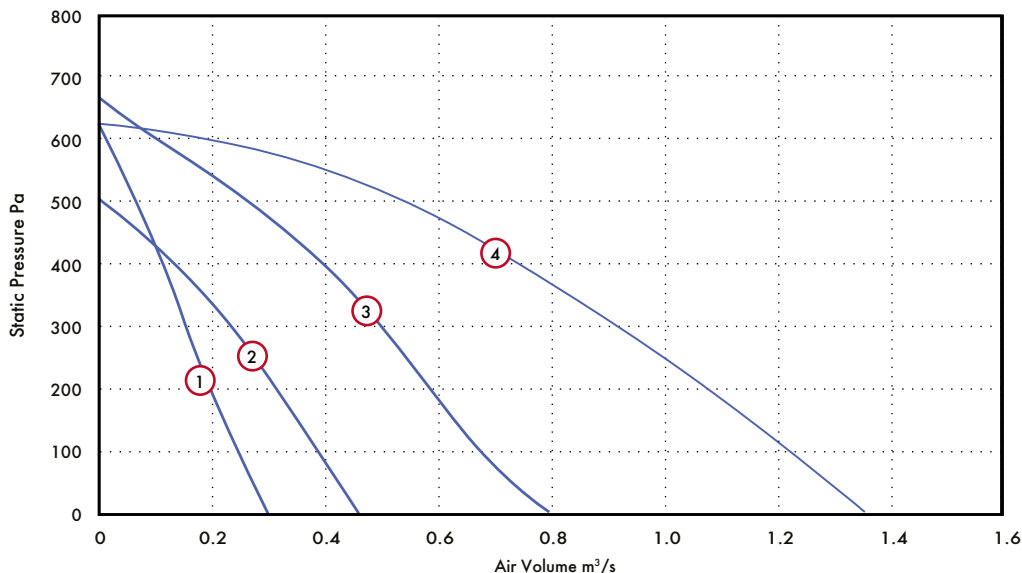

Dia.	Motor Phase	Stock Ref	IP Rating	Curve Ref.	m ³ /s @ Pa								S.C. Amps	F.L.C Amps	dB(A) @ 3m
					0	100	200	300	400	500	600				
250	1	SLPT250EC	IP44	1	m ³ /s	0.30	0.25	0.20	0.15	0.11	0.07	0.01	1.4	1.4	39
					kW	0.14	0.14	0.14	0.14	0.14	0.14	0.12			
					W/l/s	0.47	0.58	0.69	0.88	1.25	2.13	17.44			
315	1	SLPT315EC	IP44	2	m ³ /s	0.46	0.39	0.32	0.24	0.14			1.4	1.4	43
					kW	0.14	0.14	0.15	0.15	0.15					
					W/l/s	0.30	0.36	0.46	0.63	1.06					
400	1	SLPT400EC	IP44	3	m ³ /s	0.80	0.68	0.59	0.50	0.40	0.27	0.10	2.86	2.86	48
					kW	0.39	0.38	0.37	0.36	0.37	0.39	0.39			
					W/l/s	0.49	0.56	0.63	0.73	0.92	1.46	3.90			
500	3	SLPT500EC	IP54	4	m ³ /s	1.37	1.24	1.09	0.92	0.75	0.57	0.35	2.1	2.1	46
					kW	0.61	0.67	0.71	0.73	0.73	0.71	0.66			
					W/l/s	0.45	0.54	0.66	0.79	0.97	1.25	1.88			

Sound Power Level Spectra dB (ref 10⁻¹² Watts)

Dia.	Motor Phase	Stock Ref	Spectrum	63	125	250	500	1k	2k	4k	8k	dB(A) @ 3m
250	1	SLPT250EC	Inlet	64	68	61	69	60	50	50	47	47
			Outlet	63	69	62	78	66	67	61	57	56
			Breakout	61	64	61	60	49	42	36	35	39
315	1	SLPT315EC	Inlet	63	74	65	59	52	46	43	40	42
			Outlet	66	76	68	69	63	61	53	45	49
			Breakout	66	72	71	51	44	38	36	32	43
400	1	SLPT400EC	Inlet	73	82	73	66	62	53	50	45	50
			Outlet	75	85	78	77	73	69	63	55	58
			Breakout	78	77	75	61	55	48	46	41	48
500	3	SLPT500EC	Inlet	88	93	86	80	71	67	59	53	62
			Outlet	87	91	89	84	83	78	68	62	67
			Breakout	74	80	76	67	61	54	44	36	50

Models & Accessories



Fan Stock Ref	Trickle/Boost Controller Stock Ref	EC Fan Changeover Controller Stock Ref
SLPT100EC	475775	476367
SLPT125EC	475775	476367
SLPT150EC	475775	476367
SLPT200EC	475775	476367
SLPT250EC	475775	476367
SLPT315EC	475775	476367
SLPT400EC	475775	476367
SLPT500EC	475775	476367



Backdraught Shutter
Stock Ref



Fast Clamp
Stock Ref



Anti-Vibration Mounts (set of 4)
Stock Ref

Size	Backdraught Shutter Stock Ref	Fast Clamp Stock Ref	Anti-Vibration Mounts (set of 4) Stock Ref
100	10542100	10540100	68MP033G
125	10542125	10540125	68MP033G
150	10542150	10540150	68MP033G
200	10542200	10540200	68MP033G
250	10542250	10540250	68MP033G
315	10542315	10540315	68MP033G
400	10542400	10540400	68MP033G
500	-	-	68MP033G



Duct Attenuator

Size	300mm Stock Ref	600mm Stock Ref	900mm Stock Ref	1200mm Stock Ref
100	10534100	10535100	10536100	-
125	10534125	10535125	10536125	-
150	10534150	10535150	10536150	-
200	-	10535200	10536200	10537200
250	-	10535250	10536250	10537250
315	-	10535315	10536315	10537315
400	-	10535400	10536400	10537400
500	-	-	10536500	-

Models & Accessories



Size	Duct Air Heater Stock Ref	Filter Cassette Stock Ref	Bag Filter Cassette Stock Ref	Flexible Connections Stock Ref
100	10531100T1	10532100	10533100	FLX100
125	10531125T1	10532125	10533125	FLX125
150	10531150T1	10532150	10533150	FLX150
200	10531200T1	10532200	10533200	FLX200
250	10531250T1	10532250	10533250	FLX250
315	10531315T1 10531315T3	10532315	10533315	FLX315
400	10531400T3	10532400	10533400	FLX400
500	10531500T3	10532500A	10533500	FLX500

EuroSeries[®] (SDX)

- Available in sizes 100 to 315
- 200 and 250 sizes also available as high performance
- Motor Insulation Class B, protected to IP44
- Operating Temperatures from -25°C up to +60°C
- All units suitable for speed control
- Quality Assurance to BS EN ISO 9001:1994
- Performance tested to BS848 Part 1 1980
- 2 Year Warranty

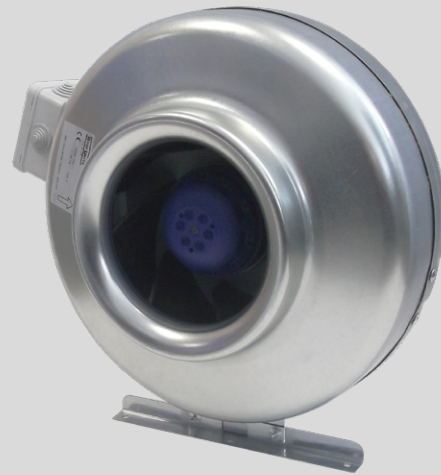

The SDX Euroflow in-line centrifugal duct fans are designed around an efficient backward curved centrifugal impeller and external rotor motor to ensure a compact design, high performance and low sound levels.

The in-line fan casing is constructed from pressed steel and incorporates an aerodynamically designed airflow guide vane, ensuring maximum performance from the unit whilst maintaining minimum noise levels. All models are supplied with a simple mounting foot for ease of installation.

The SDX range is available in eight model sizes: 100, 125, 150, 200, 250 & 315mm diameter as standard performance and sizes 200 and 250 also available as a high performance in-line centrifugal duct fan. The range provides a performance up to 0.372m³/s with a maximum pressure development of 500 Pa.

The SDX range is suitable for the extract of clean air only. It is not suitable for extracting or transporting grinding dust, soot, explosive or other aggressive gases etc.

Impellers

The impellers are aerodynamically designed centrifugal backward curved type, manufactured by injection moulding of a polypropylene resin. The motor and impeller is factory matched, statically and dynamically balanced in two planes to ISO 1940, Grade G 6.3.

Motors

All units are fitted with motors protected to IP44, insulation Class B and are suitable for temperatures ranging from -25°C to +60°C with humidity levels of up to 95% RH ensuring reliable operation. All sizes are for a 220V/1/50Hz electrical supply and incorporate a manual reset thermal protection device.

Terminal Box

An IP54 terminal box fitted to the casing with multiple cable entry positions.

Performance

The fan performance is in accordance with tests to BS848 Part 1 1980, with the fan sound levels measured in a reverberant chamber in accordance with BS848 Part 2 1985.

Quality Assurance

Design and manufacture is in accordance with the standard for quality management systems BS EN ISO 9001:1994.

Accessories

A full range of accessories are available with the Euroflow in-line centrifugal duct fans such as:

- Electronic Speed Controllers
 - Auto Transformer Speed Controllers
 - D.O.L. Starter and Overload
 - Pre & Secondary Filter Cassettes
 - Electric Heater Batteries
 - In-Line Attenuators
 - Backdraught Shutters
 - Fast Clamps
 - Flexible Ducting
 - Wall Terminals
 - Roof Terminals
-

Dimensions (mm)

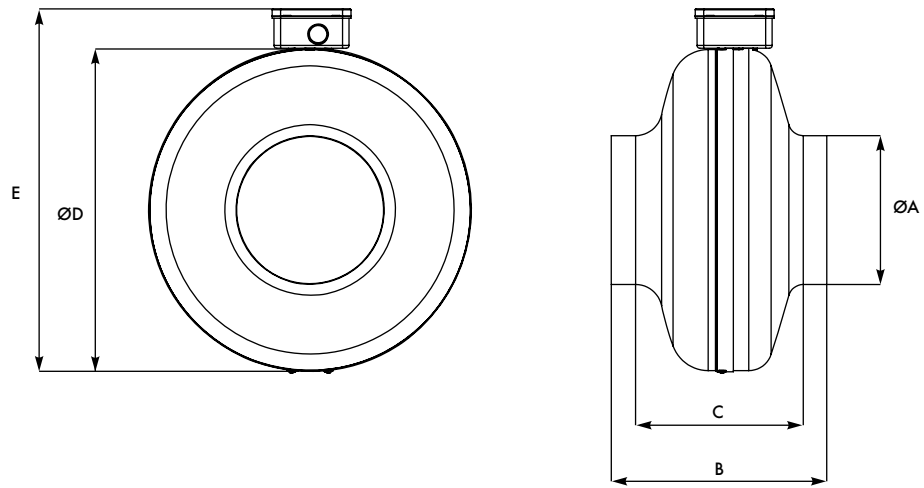

Unit Size	ØA	B	C	ØD	E	kg
SDX100	100	189	152	244	287	3
SDX125	125	182	143	243	286	3
SDX150	150	217	166	344	387	3
SDX200	200	219	167	344	387	4
SDX200H	200	231	179	344	387	4.7
SDX250	250	223	167	344	387	4
SDX250H	250	230	167	344	387	4.7
SDX315	315	243	175	402	444	5.6

Performance Guide

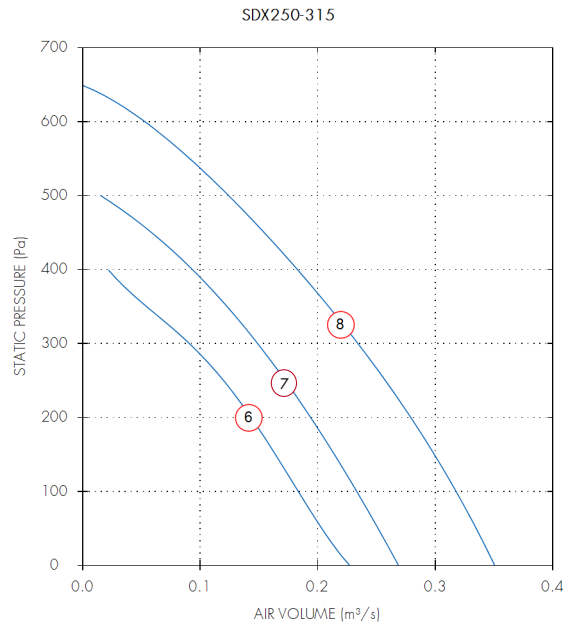
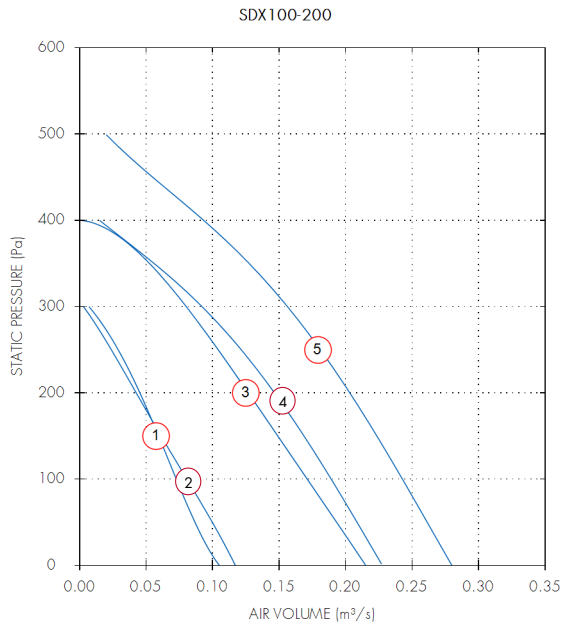

Dia.	Motor Phase	Stock Ref	r.p.m	IP Rating	Curve Ref.	m³/s @ Pa						Motor kW	F.L.C Amps	dB(A) @ 3m
						0	100	200	300	400	500			
100	1	SDX100C	2800	IP44	1	0.11	0.07	0.05				0.07	0.31	26
125	1	SDX125C	2800	IP44	2	0.12	0.08	0.04				0.08	0.31	24
150	1	SDX150C	2800	IP44	3	0.22	0.17	0.13	0.08			0.1	0.44	35
200	1	SDX200C	2600	IP44	4	0.23	0.19	0.15	0.09			0.11	0.45	34
200	1	SDX200HC	2660	IP44	5	0.28	0.24	0.2	0.16	0.09		0.14	0.56	38
250	1	SDX250C	2600	IP44	6	0.23	0.18	0.14	0.09			0.11	0.45	31
250	1	SDX250HC	2460	IP44	7	0.27	0.23	0.19	0.15	0.09	0.02	0.13	0.56	34
315	1	SDX315C	2567	IP44	8	0.35	0.32	0.28	0.23	0.18	0.12	0.22	0.96	36

Sound Power Level Spectra dB (ref 10⁻¹² Watts)

Dia.	Motor Phase	Stock Ref	Spectrum	dB(A) @ 3m							
				125	250	500	1k	2k	4k	8k	dB(A) @ 3m
100	1	SDX100C	Inlet	53	58	60	66	65	58	47	49
100	1	SDX100C	Outlet	54	60	61	67	66	58	48	50
100	1	SDX100C	Breakout	34	58	44	55	54	47	37	39
125	1	SDX125C	Inlet	50	54	63	65	64	56	47	48
125	1	SDX125C	Outlet	49	53	61	64	63	55	45	47
125	1	SDX125C	Breakout	28	29	45	53	52	44	35	36
150	1	SDX150C	Inlet	51	66	67	71	62	61	53	52
150	1	SDX150C	Outlet	52	67	68	72	64	63	50	54
150	1	SDX150C	Breakout	30	49	51	60	52	50	36	41
200	1	SDX200C	Inlet	46	53	62	66	63	64	54	50
200	1	SDX200C	Outlet	45	54	61	68	64	65	53	51
200	1	SDX200C	Breakout	22	24	41	49	53	43	40	35
200	1	SDX200HC	Inlet	53	60	66	69	66	65	63	53
200	1	SDX200HC	Outlet	54	62	65	70	67	67	63	54
200	1	SDX200HC	Breakout	25	35	46	53	55	47	45	38
250	1	SDX250C	Inlet	41	52	61	66	66	64	56	51
250	1	SDX250C	Outlet	43	53	60	68	67	65	57	52
250	1	SDX250C	Breakout	24	30	38	48	47	45	40	32
250	1	SDX250HC	Inlet	54	62	67	69	67	67	65	54
250	1	SDX250HC	Outlet	55	63	66	70	68	67	65	54
250	1	SDX250HC	Breakout	33	38	47	50	48	47	46	34
315	1	SDX315C	Inlet	50	59	67	68	66	65	64	52
315	1	SDX315C	Outlet	51	60	66	69	67	66	65	53
315	1	SDX315C	Breakout	33	38	45	48	47	45	43	32

Models & Accessories

Fan	Speed Controller		Starter (requires Overload)	Overload
Stock Ref	Stock Ref	Stock Ref	Stock Ref	Stock Ref
SDX100C	SC5001	SPM5020	444744	444696
SDX125C	SC5001	SPM5020	444744	444696
SDX150C	SC5001	SPM5020	444744	444697
SDX200C	SC5001	SPM5020	444744	444698
SDX200HC	SC5001	SPM5020	444744	444699
SDX250C	SC5001	SPM5020	444744	444698
SDX250HC	SC5001	SPM5020	444744	444699
SDX315C	SC5001	SPM5020	444744	444699

Dia	In-Line Attenuators			
	300mm Stock Ref	600mm Stock Ref	900mm Stock Ref	1200mm Stock Ref
100	83010030	83010060	83010090	-
125	83012030	83012060	83012090	-
150	83015030	83015060	83015090	-
200	-	83020060	83020090	83020120
250	-	83025060	83025090	83025120
315	-	83031060	83031090	83031120

Fan	Wall Terminal	Wall Terminal	Electric Heaters	Panel Filters
Stock Ref	Stock Ref	Stock Ref	Stock Ref	Stock Ref
100	SA100/280	SA100/80	10531100T1	QPF100A
125	SA125/280	SA125/80	10531125T1	QPF125A
150	SA150/280	SA150/80	10531150T1	QPF150A
200	SA200/280	SA200/80	10531200T1	QPF200A
250	SA250/280	SA250/80	10531250T1	QPF250A
315	SA315/280	SA315/80	10531315T1	QPF315A

Fan	Bag Filters	Roof Terminal	Louvre Shutter
Stock Ref	Stock Ref	Stock Ref	Stock Ref
100	QPFB100A	WRC100	LS250
125	QPFB125A	WB160	LS250
150	QPFB150A	WB160	LS250
200	QPFB200A	WB200	LS250
250	QPFB250A	RCZ300	LS250
315	QPFB315A	RCZ300	LS315

Speed Controllers

Single Phase SPM (Auto-Transformer)



- Single Phase, 5 step auto-transformer speed controller
- Low motor noise - no magnetic hum
- ON/OFF Switch

Unit	Max Peak	Dimensions	Weight	Enclosure	Damper
Stock Ref	Load Current	H x W x D (mm)	kg		Connection
SPM5020	2.0	230 x 168 x 118	2.2	IP54	Yes
SPM5035	3.5	230 x 168 x 118	4.6	IP54	Yes
SPM5060	6.0	230 x 166 x 118	5.0	IP50	Yes
SPM5075	7.5	284 x 240 x 132	6.2	IP54	Yes
SPM5090	9.0	316 x 270 x 168	10.5	IP54	No
SPM5140	14.0	316 x 270 x 168	16.5	IP54	No

Stock Ref
SPM5020
SPM5035
SPM5060
SPM5075
SPM5090
SPM5140

Single Phase RTRE (Enhanced Auto-Transformer)



- Single Phase 5 step auto-transformer speed controller
- Separate starter not required when used with HOT SPOT protected fans
- Low motor noise - no magnetic hum
- Additional terminals to allow connection of remote switching device
- Allows operation via BMS interface
- Additional terminals to allow connection of remote anti-freezing thermostat

Unit	Max Peak	Dimensions	Weight	IP	Damper	VFC
Stock Ref	Load Current	H x W x D (mm)	kg		Connection	
RTRE20	2.0 amps	230 x 166 x 118	2.3	IP54	Yes	Yes
RTRE35	3.5 amps	230 x 166 x 118	3.6	IP54	Yes	Yes
RTRE60	6.0 amps	230 x 166 x 118	5.1	IP54	Yes	Yes
RTRE90	9.0 amps	284 x 240 x 132	10.6	IP54	Yes	Yes

Stock Ref
RTRE20
RTRE35
RTRE60
RTRE90

Three Phase RDTK (Auto - Transformer)



- Three phase 5 step auto - transformer speed controller
- Separate starter not required when used with HOT SPOT protected fans
- Low motor noise - no magnetic hum
- Compact fire retardant surface mounting enclosure
- Additional terminals to allow connection of remote switching device
- Additional terminals to allow connection of remote anti-freezing thermostat

Unit	Max Peak	Dimensions	Weight	Damper	
Stock Ref	Load Current	H x W x D (mm)	kg	Enclosure	Connection
RDTK10	1.0 amps	284 x 240 x 132	4.7	IP54	Yes
RDTK20	2.0 amps	284 x 240 x 132	7.4	IP54	Yes
RDTK40	4.0 amps	316 x 270 x 168	12.9	IP21	No
RDTK70	7.0 amps	324 x 270 x 168	15.6	IP21	Yes
RD14	14.0 amps	295 x 400 x 170	30.0	IP21	No

Stock Ref

RDTK10
RDTK20
RDTK40
RDTK70
RD14

Starters & Overloads

- Suitable for all models
- Push button Start/Stop
- 240V contactor coil for single phase applications and three phase supplies where a neutral is present
- 415V contactor coil for three phase supplies where a neutral is not present or required
- Protection is given by an overload relay which is selected to match the load of the fan
- Enclosures are protected to IP55



Stock Ref	Starters	DOL Rating (Amps)	Star Delta Rating (Amps)	Dimensions H x W x D	Weight kg
444744	DOL Starter 1 Phase 240V 12A	12	-	174x104x134	3.0
444745	DOL Starter 1 Phase 240V 25A	25	-	174x104x134	1.5
444746	DOL Starter 1 Phase 240V 32A	32	-	184x184x149	2.5
444747	DOL Starter 3 Phase 415V 12A	12	-	174x104x134	3.0
444748	DOL Starter 3 Phase 415V 25A	25	-	174x104x134	3.5
444749	DOL Starter 3 Phase 415V 32A	32	-	184x184x149	2.5
444750	DOL Starter 3 Phase 415 V 50A	50	-	305x285x159	7.0
444842	Star Delta Starter 21A	-	21	184x284x149	3.5
444843	Star Delta Starter 30A	-	30	184x284x149	3.5

Stock Ref	Overloads	DOL Rating (Amps)	Star Delta Rating (Amps)
444696	OVERLOAD 0.16-0.25	0.16-0.25	-
444697	OVERLOAD 0.25-0.40	0.25-0.40	-
444698	OVERLOAD 0.40-0.63	0.40-0.63	-
444699	OVERLOAD 0.63-1.0	0.63-1.0	-
444700	OVERLOAD 1.0-1.6	1.0-1.6	-
444701	OVERLOAD 1.6-2.5	1.6-2.5	2.7-4.3
444702	OVERLOAD 2.5-4.0	2.5-4.0	4.3-6.9
444703	OVERLOAD 4.0-6.0	4.0-6.0	6.9-10
444704	OVERLOAD 5.5-8.0	5.5-8.0	9.5-13.8
444705	OVERLOAD 7-10	7-10	12-17
444706	OVERLOAD 10-13	10-13	17-22
444707	OVERLOAD 13-18	13-18	22-31
444708	OVERLOAD 18-25	18-25	31-43
444709	OVERLOAD 23-32	23-32	39-55

This range of Starters and Overloads is not cross compatible with previous versions.

Sonex Circular Sound Attenuators

- Low cost - exceptional performance
- Ex stock availability
- Sheet steel casing and end plates 30 minute fire rating as standard
- Fitted spigot for direct connection to circular ductwork

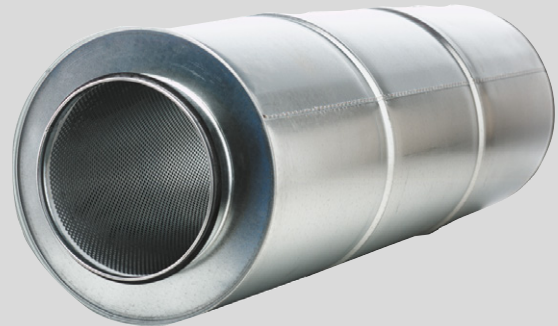

Application

The effective and economic solution for sound attenuation in circular duct systems from 100 to 500mm diameter. With at least three models per size throughout the range the system designer is given complete flexibility of choice allowing a selection which is the best balance of attenuation, size and cost for any application. Sonex Attenuators are fitted with a patented duct seal which enables leak free 'plug-in' connection to rigid ductwork with consequent savings of installation costs. The excellent attenuation characteristics of the Sonex range are achieved without imposing undue system resistance. Pressure losses are little more than those which would occur over a comparable section of straight duct.

Construction

The attenuator consists of a perforated tubular liner manufactured from sheet steel. The liner is enclosed by a thick layer of mineral wool sound absorbing material. Casing and end plates are formed from galvanised sheet steel. Standard models have a 30 minute fire rating (60 minutes also available).

Dimensions, Weights & Insertion Loss

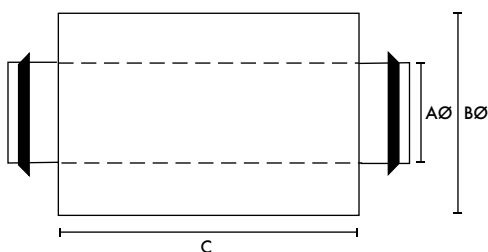

Stock Ref	Dimensions (mm)			Attenuation dB mid Frequency Hz								
	AØ	BØ	C	kg.	63	125	250	500	1K	2K	4K	8k
83010030	100	200	300	2.4	3	3	9	17	23	26	25	13
83010060	100	200	600	4.1	6	9	15	34	40	40	37	18
83010090	100	200	900	6.6	10	13	21	40	45	39	36	16
83012030	125	225	300	2.6	3	3	7	16	20	24	22	17
83012060	125	225	600	4.5	5	8	13	29	35	35	32	22
83012090	125	225	900	7.6	10	12	19	37	40	38	34	32
83015030	150	260	300	2.9	3	3	6	13	19	23	22	16
83015060	150	260	600	5.8	5	7	12	24	30	35	31	20
83015090	150	260	900	9	8	10	15	32	38	37	34	29
83016030	160	260	300	2.9	3	3	6	13	19	23	22	16
83016060	160	260	600	5.8	5	7	12	24	30	35	31	20
83016090	160	260	900	9	8	10	15	32	38	37	34	29
83020060	200	300	600	7	4	6	10	20	27	33	19	17
83020090	200	300	900	10	8	9	14	28	32	35	28	25
83020120	200	300	1200	14	10	12	17	36	41	43	28	26
83025060	250	355	600	8.6	4	5	10	19	25	29	18	17
83025090	250	355	900	12.2	6	7	12	23	30	30	22	19
83025120	250	355	1200	18	8	10	15	32	37	38	26	20
83031060	315	400	600	9.8	4	5	8	15	20	22	17	15
83031090	315	400	900	15	5	7	10	20	30	29	18	16
83031120	315	400	1200	21	7	9	13	22	32	33	19	18
83040090	400	606	900	21	3	5	9	19	26	20	13	11
83040120	400	606	1200	27	6	8	14	24	30	28	17	9
83050090	500	711	900	29	3	4	9	15	23	17	12	11
83050120	500	711	1200	38	5	7	13	18	26	23	15	9

Pyrocheck Intumescent Fire Dampers

- Suitable for air transfer in doors and partitions
- Complete seal achieved in approximately five minutes when tested in accordance with BS 476 pt 20 & 22
- UV Stabilised material UPVC
- Pyrocheck offer much lower resistance to airflow compared to traditional designs
- Independently tested to BS 476 pt. 22; fire integrity of 68 mins



Pyrocheck CVT Intumescent Fire Dampers are circular and have a minimum fire integrity of one hour (in accordance with BS476 Part 8 1972). The fire dampers have been independently tested at the Warrington Fire Research Centre.

Intumescent fire dampers require no mechanical or external device to operate as they rely solely on an internal reaction initiated by heat. They are, therefore, especially suitable for applications where regular inspection is unlikely or difficult or where mechanical devices would be susceptible to shock or corrosion damage.

Typical applications are air transfer in fire doors or partitions.

The active material is encased in a PVC sleeve giving maximum protection against moulds, fungi, insect attack or similar biological damage, and may reasonably be expected to last for the life of the building. Unaffected by UV light, capable of withstanding freeze/thaw cycling and able to support ambient temperatures within the range -10°C to +80°C.

In a fire situation Pyrocheck CVT Dampers will rapidly expand to completely block the duct or opening thus preventing the further passage of smoke and hot gases.

An unusually high free area means that Pyrocheck CVT Dampers offer much lower resistance to air flow compared to traditional intumescent designs.

Dimensions

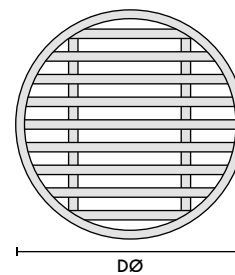

Stock Ref	DØ
CVT100	100
CVT130	125
CVT150	150
CVT200	198
CVT250	248
CVT300	298

Vent-Axia does not guarantee compliance with Building Regulations Part B, Fire Spread or other regulations that relate to fire planning. Suitability to comply with these regulations should be determined prior to installation and in conjunction with Building Control Officers. Compliance with the Regulations is specifically excluded from quotations and designs.

Models

Size	Stock Ref
4" Ø	CVT100
5" Ø	CVT130
6" Ø	CVT150
8" Ø	CVT200
10" Ø	CVT250
12" Ø	CVT300

Unitex Roof Cowl System

- Complete weather proofing with low pressure drop
- Size 160 to 250 supplied with bird guard
- Galvanised steel construction additionally protected by a dark brown epoxy powder coat finish (110mm grey PVC)
- Weather apron in stock aluminium
- Suitable for flat or pitched roofs up to 20° as standard
- Can be supplied in special colours to match building design (110mm grey PVC only)



The Unitex Roof Cowl System greatly simplifies the roof termination of mechanical ventilation systems. Consisting of an attractive epoxy finished cowl with a lead weather slate and a range of direct connection reducing fittings. It is suitable for connection to spiral duct, soil pipe and flexible duct from 125 to 250mm diameter.

Product Range

Cowl Assembly

WB160 For ducts from 125 to 160mm

WB200 For ducts from 200 to 250mm

Weather Apron for Flat Roofs

WA160

WA200

Weather Apron for Pitched Roofs (20° MAX)

WA160/20

WA200/20

Adaptor

370304 (125 to 150mm)

370309 (200 to 250mm)

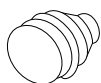
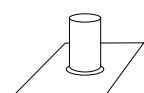
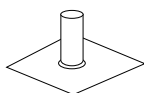
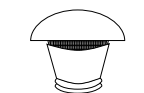

Installation with an Adaptor

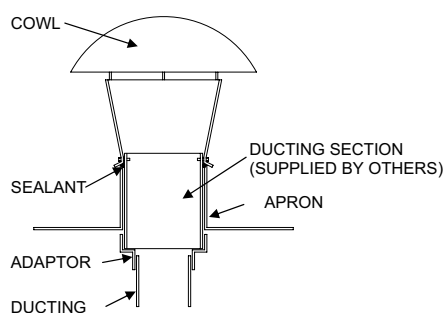

WB160 with 125mm connection using adaptor 370304

WB200 with 250mm connection using adaptor 370309

Models



110mm (4") Roof System

Description

PVC Roof Cowl

Weather Apron (pitch roofs)

Stock Ref

WRC100

WA100



125mm to 160mm Roof System

Description

Roof Cowl - Standard Colour BSO8B29

Roof Cowl - Non-standard Colour

Weather Apron (flat roofs)

Stock Ref

WB160

WB160C

WA160



200mm to 250mm Roof System

Description

Roof Cowl - Standard Colour BSO8B29

Roof Cowl - Non-standard Colour

Weather Apron (flat roofs)

Stock Ref

WB200

WB200C

WA200

Weather Apron for pitched roof

Description

Weather Apron 20° (max) pitch roof

Weather Apron 20° (max) pitch roof

Stock Ref

WA160/20

WA200/20

Adaptor

Description

OR16012 (125 to 150mm)

OR25020 (200 to 250mm)

Stock Ref

370304

370309

Unitex Wall Terminals

- External weather louvre, wall sleeve and duct connection spigot in one unit
- Satin anodised louvre gives full weather protection
- Epoxy powder coated finish, weather louvre available as optional extra
- 280mm or 80mm wall sleeve section
- Spigot connections from 100mm to 400mm



The Unitex SA Wall Terminal Module consists of a high grade satin anodised weather louvre fitted with bird guard (epoxy finish to BS or RAL standard colour available at extra cost). This is located in a galvanised sheet metal 'box section' linked to a reinforced circular stub for direct connection to rigid or flexible ductwork.

Two lengths of 'box section' are available; 80mm and 280mm. An airstream operated back draught shutter can be fitted in the 280mm version. For applications where larger air volumes are involved the Unitex QSA range of wall terminals is available.

Note:

Volume Control Dampers, Speed Clamps & Backdraught Shutters available: see Accessories Section.

Models

Description	Stock Ref
80mm wall sleeve, std. format louvre	
100mm	SA100/80
125mm	SA125/80
150mm	SA150/80
200mm	SA200/80
250mm	SA250/80
315mm	

80mm wall sleeve, large format louvre	
125mm	QSA125/80
200mm	QSA200/80
250mm	QSA250/80
315mm	QSA315/80

280mm wall sleeve, std. format louvre	
100mm	SA100/280
125mm	SA125/280
150mm	SA150/280
200mm	SA200/280
250mm	SA250/280
315mm	SA315/280

280mm wall sleeve, large format louvre

100mm	QSA100/280
125mm	QSA125/280
150mm	QSA150/280
200mm	QSA200/280
250mm	QSA250/280
315mm	QSA315/280
400mm	QSA400/280

Dimensions (mm)

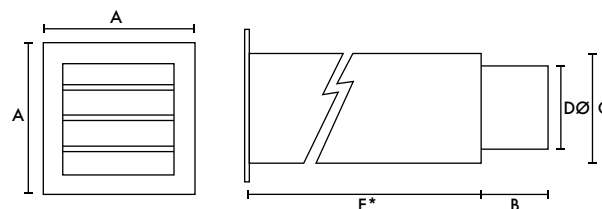

*Dimensions E select from 280 or 80mm

Model Ref	A	B	C	DØ
SA100	180	80	130	99
SA125	210	80	160	124
SA150	230	80	180	149
SA200	280	80	230	199
SA250	330	80	280	249
SA315	400	80	350	313
QSA100	230	80	180	98
QSA125	280	80	230	124
QSA150	330	80	280	149
QSA200	400	80	350	199
QSA250	500	80	450	249
QSA315	550	80	500	313
QSA400	550	80	500	400

VENT-AXIA CONTACT NUMBERS

Free technical, installation and sales advice is available

Sales Tel:	0344 856 0590
Sales Fax:	01293 565169
Tech Support Tel:	0344 856 0594
Tech Support Fax:	01293 532814
Web:	www.vent-axia.com
Email:	sales@vent-axia.com

Supply & Service

All sales made by Vent-Axia Limited are made only upon the terms of the Company's Conditions of Sale, a copy of which may be obtained on request. As part of the policy of continuous product improvement Vent-Axia reserves the right to alter specifications without notice.



Download our Knowledge Hub app - Your new pocket expert.

Search, View, Share - It's that easy!



Made in Britain



0223